

The Oracle logo is displayed in a bold, red, sans-serif font. The background of the slide features a light gray grid with various geometric shapes: a large gear in the upper left, several circles of different sizes and colors (red, gray, orange), and thick, curved red lines at the bottom.

Cloud Infrastructure

Roving Edge Infrastructure

August 23, 2024

Contents

Roving Edge Infrastructure.....	6
Overview.....	6
Prerequisites.....	7
Differences from Oracle Cloud Infrastructure.....	8
Tagging Resources.....	8
Contacting Oracle Support.....	8
Viewing a PDF of this Guide.....	8
Concepts.....	8
Device Specifications.....	10
Safety and Compliance Resources.....	13
Self-Encryption.....	13
Tamper-Evident Seals.....	13
Ultra Battery Options.....	13
Service Ports.....	13
Running CLIs on Device-Hosted Compute Instances.....	14
Country Support.....	14
Supported Regions for Roving Edge Infrastructure.....	14
Countries Where You Can Ship Devices.....	14
Service Limits.....	21
Requesting Devices.....	21
Device Ordering Requirements.....	22
Request a Device.....	23
Viewing Your Request Status.....	23
How Oracle Provisions Your Request.....	23
Establishing the Certificate Authority.....	23
Setting Up Oracle Roving Edge Device.....	24
Receive and Inspect the Shipment.....	24
Remove the Ruggedized Case End-Caps.....	27
Mount the Device in a Rack.....	29
Cable the Device.....	32
Set Up Terminal Emulation.....	33
Power On the Device.....	34
Configure Network Parameters.....	34
Unlock the Device.....	35
Download the Root CA Certificate.....	36
Administering Devices.....	37
Operating the Serial Console.....	37
Resetting Devices.....	38
Avoiding Storage Overages Using Safe Mode.....	38
Managing the Banner.....	39
Managing the Network.....	39
Managing Your Password.....	40
Managing Your System Upgrades.....	40
Displaying the Serial Encryption Key.....	41
Accessing a Device.....	41
Accessing the Oracle Cloud Infrastructure Cloud Console.....	41
Accessing the Roving Edge Infrastructure Device Console.....	41
Command Line Interface.....	44
API.....	44

Using the Command Line Interface.....	45
Minimum Required CLI Version.....	45
Determining CLI Versions.....	45
Updating Your Hosts File.....	45
Installing the CLI.....	46
Setting Up the Config File.....	46
Setting Up the OCI CLI RC File.....	48
Using the CLI.....	49
Required and Optional Parameters.....	51
Running CLIs on a VM Instance.....	51
Unsupported CLI Commands.....	51
Accessing Command Line Interface Help.....	53
Ruggedizing Devices.....	53
Compartments.....	61
Usage Guidelines.....	62
Storage Capacity Usage.....	62
CPU Usage Recommendations.....	62
Setting Policies.....	62
Allowing Access to Roving Edge Infrastructure Resources in OCI.....	62
Allowing the Roving Edge Infrastructure Service to Attach Workloads.....	63
Ordering Roving Edge Infrastructure Devices Using the Console.....	63
Allowing Your Roving Edge Infrastructure Devices Object Storage Access.....	63
Enabling Disconnected Upgrade Bundle Delivery.....	64
Enabling Certificate Management.....	64
Policy Examples.....	65
Permissions.....	65
Block Volume.....	66
Certificates.....	82
Compute.....	83
Data Synchronization.....	96
Diagnostics.....	97
Events.....	99
Identity (IAM).....	100
Monitoring.....	104
Networking.....	105
Object Storage.....	116
System Upgrades.....	119
Managing Master Keys.....	120
Using Your Own Master Key.....	120
Shredding the Master Key.....	122
Recovering Your Device After Shredding the Master Key.....	122
Getting Started.....	122
Creating and Launching Instances.....	123
Managing Files Using Object Storage.....	125
Syncing Your Data.....	127
Device Nodes.....	127
Creating a Device Node.....	128
Attaching a Workload to a Device Node.....	130
Listing Workloads for a Device Node.....	132
Deleting a Workload from a Device Node.....	132
Submitting a Device Node Request.....	133
Listing Device Nodes.....	134
Listing Device Node Shapes.....	134
Getting a Device Node's Details.....	134
Editing a Device Node.....	135
Moving a Device Node Between Compartments.....	135

Deleting a Device Node.....	136
Ultra Nodes.....	137
Creating an Ultra Node.....	138
Attaching a Workload to an Ultra Node.....	140
Listing Workloads for an Ultra Node.....	141
Deleting a Workload from an Ultra Node.....	142
Submitting an Ultra Node Request.....	143
Listing Ultra Nodes.....	143
Listing Ultra Node Shapes.....	144
Getting an Ultra Node's Details.....	144
Editing an Ultra Node.....	145
Moving an Ultra Node Between Compartments.....	145
Deleting an Ultra Node.....	146
Using USB Devices with Ultra Nodes.....	146
Attaching OCI Marketplace-Based Workloads.....	147
Device Monitoring.....	148
Monitoring Roving Edge Device Status.....	149
Device Metrics.....	149
Using the Device Console.....	149
Data Synchronization.....	150
Creating a Data Sync Task.....	150
Listing Data Sync Tasks.....	151
Getting a Data Sync Task's Details.....	151
Editing a Data Sync Task.....	152
Starting a Data Sync Task.....	152
Stopping a Data Sync Task.....	152
Deleting a Data Sync Task.....	153
Device Software Version Management.....	153
Identifying the Device Software Version.....	153
Updating the Device Software while Connected.....	154
Updating the Device Software while Disconnected.....	155
Rolling Back the Device Software to the Previous Version.....	157
Collecting Device Diagnostic Information.....	157
Creating a Diagnostic Bundle.....	158
Listing Diagnostic Bundles.....	158
Getting a Diagnostic Bundle's Details.....	158
Downloading a Diagnostic Bundle.....	158
Canceling a Diagnostic Bundle in Progress.....	159
Running Diagnostic Commands.....	159
Creating a Diagnostic Command.....	160
Listing Diagnostic Commands.....	160
Getting a Diagnostic Command's Details.....	160
Downloading a Diagnostic Command's Output.....	161
Canceling a Diagnostic Command in Progress.....	161
Certificate Management.....	161
Getting a Certificate's Details.....	162
Getting a Certificate Authority (CA) Bundle's Details.....	162
Updating a Certificate's Details.....	163
Renewing a Certificate while Connected.....	163
Renewing a Certificate while Disconnected.....	164
Creating a Certificate while Connected.....	166
Creating a Certificate while Disconnected.....	167
Identity and Access Management (IAM).....	168
Users.....	169
User Credentials.....	172
User Groups.....	180

Applying Lockout Policies to Users.....	184
Compute Virtual Machine Infrastructure.....	185
Preserving Hosts File Edits.....	185
Updating DNS.....	186
Adding cloud-init Information.....	186
Oracle Repositories on Oracle Linux Instances.....	186
Running CLIs on Device-Hosted Compute Instances.....	187
Instances.....	189
Configuring Multiple VNICs.....	201
Updating a VM when the IP Pool Range Changes.....	202
Custom Images.....	202
Boot Volumes.....	211
Console History Capture.....	216
Object Storage.....	219
Performance and Usage Thresholds.....	219
Amazon S3 Compatibility API.....	219
Buckets.....	227
Objects.....	231
Running Functions on Object Storage.....	239
Object Versioning.....	240
Block Volumes.....	243
Creating a Block Volume.....	244
Listing Block Volumes.....	245
Getting a Block Volume's Details.....	245
Renaming a Block Volume.....	246
Deleting a Block Volume.....	246
Block Volume Attachment Management.....	247
Networking.....	249
Public IP Addresses.....	249
Virtual Cloud Networks (VCNs).....	254
Subnets.....	257
Virtual Network Interface Cards (VNICs).....	260
Events.....	264
Creating an Events Rule.....	264
Listing Events Rules.....	265
Getting an Events Rule's Details.....	266
Editing an Events Rule.....	266
Enabling an Events Rule.....	267
Disabling an Events Rule.....	267
Deleting an Events Rule.....	267
Returning Devices to Oracle.....	268
Contacting Oracle for Device Return.....	268
Preparing Devices for Return.....	268
Returning Non-Working Devices.....	269
Troubleshooting.....	269
General.....	269
System Upgrade.....	270
Networking.....	270
Storage.....	270
Compute/Instances.....	272
Data Synchronization.....	275
Known Issues.....	276
An Oracle Linux 9 instance takes a while to boot.....	276

Roving Edge Infrastructure

Use Roving Edge Infrastructure to put fundamental Oracle Cloud Infrastructure services where data is generated and consumed, regardless of network connectivity, through the use of Roving Edge Devices.

[What's new](#)

Get Started

[Overview of Roving Edge Infrastructure](#)

[Access Roving Edge Infrastructure](#)

[Review device specifications](#)

[Set up Roving Edge Infrastructure](#)

[Manage nodes](#)

[Product page](#)

Troubleshooting

[Troubleshooting on page 269](#)

On-Device Services

[Identity and access management](#)

[Compute virtual machine infrastructure](#)

[Object storage](#)

[Block volumes](#)

[Networking](#)

[Functions](#)

Device Tasks

[Monitor devices](#)

[Manage device software versions](#)

[Synchronize device data with OCI](#)

Developer Tools

[API for Roving Edge Infrastructure](#)

[CLI for Roving Edge Infrastructure](#)

[SDKs and the CLI](#)

[Cloud Shell](#)

Community

[Oracle Cloud Infrastructure blog](#)

[Cloud infrastructure community forum](#)

Support

[Getting Help and Contacting Support](#)

[Create a service request](#)

Overview of Oracle Roving Edge Infrastructure

Learn about the Roving Edge Infrastructure service and associated devices, including how it works and what it does.

Oracle Roving Edge Infrastructure is a cloud-integrated service that puts fundamental Oracle Cloud Infrastructure services where data is generated and consumed. Roving Edge Infrastructure devices provide high-performance computing, such as analytics, machine learning, and location-based services, and storage capabilities that operate with intermittent or no internet connectivity.

Roving Edge Infrastructure is the extension of your Oracle Cloud Infrastructure tenancy. You request to have virtual machines and objects from your tenancy loaded onto Oracle Cloud Infrastructure devices by creating and configuring Oracle Cloud Infrastructure device node resources in Oracle Cloud Infrastructure. These nodes function as requests for the corresponding devices, and also indicate what Oracle Cloud Infrastructure-based content is to be pre-loaded, or provisioned, on them. You can synchronize your object storage datasets with your Oracle Cloud Infrastructure tenancy after establishing an internet connection between the RED and your home Oracle Cloud Infrastructure region.

How to Use Roving Edge Infrastructure

Common uses for Roving Edge Infrastructure include:

- Storage and processing of large volumes of images, video, audio, and internet of things (IoT) sensor data generated in environments where WAN connection is latent or unavailable. You can pre-process, filter, compress, and secure the data locally, then transfer it to Oracle Cloud Infrastructure where it can be further processed in the cloud.
- Compute and IO intensive applications, where low latency is paramount, such as tactical reconnaissance or 5G communications.
- Machine learning, where models trained in the cloud are running in disconnected locations to improve efficiency, intelligence and productivity.
- Remote computing requiring elevated security and airtight containment of data.
- Low-latency Oracle Database and Analytics workloads, with more Oracle applications optimized over time.

Note:

Ordering Oracle Roving Edge Infrastructure devices requires important terms and conditions to be understood and acknowledged before taking possession. Confirm that these terms and conditions have been included as part of your Oracle Cloud agreement. After Oracle validates your request, your Roving Edge Infrastructure devices are provisioned and available for your possession.

Roving Edge Infrastructure Device Options

The physical component is the Roving Edge Infrastructure device, which allows you to transport and establish your Oracle Cloud Infrastructure environment where you need it. Roving Edge Infrastructure device options consist of the following:

- **Roving Edge device (RED):** A portable high-powered server that has been ruggedized to operate in remote and austere environments. These devices are highly portable and can be set up and taken down as needed.
- **Roving Edge Ultra (Ultra):** A single device contained in a backpack-like transporter that an individual can carry. Ultra doesn't require a separate power source. A single person can operate Ultra in a remote or difficult environment where establishment of REDs isn't feasible. Ultra has less storage and computing capabilities than a RED.

The Roving Edge Infrastructure devices arrive preconfigured and ready for use. Just power the devices up, configure the network settings, and connect to your local network. You can synchronize object storage data between your Roving Edge Infrastructure devices and your Oracle Cloud Infrastructure tenancy.

Prerequisites

This section describes prerequisites for requesting and using the Roving Edge Infrastructure service and its associated devices.

Knowledge Requirements

Using the Roving Edge Infrastructure service and Roving Edge Infrastructure devices has the following knowledge requirements:

- Experience and understanding of Oracle Cloud Infrastructure services and features. Be comfortable creating and managing service resources such as compute instances, object storage buckets, and Identity and Access Management (IAM) tasks before ordering REDs.
- Expertise in hardware device integration, including cabling and switching.

Oracle Cloud Infrastructure Requirements

Before you can order and set up REDs within your environment, you must perform the following prerequisite tasks:

- Establish an existing Oracle Cloud Infrastructure tenancy.
- Determine what Oracle Cloud Infrastructure-based workloads (buckets and images) you want to be installed on the REDs.

- Determine whether you need a single RED or a Roving Edge Ultra to meet your needs.

Differences from Oracle Cloud Infrastructure

Roving Edge Infrastructure differs from Oracle Cloud Infrastructure in the following ways:

- All Roving Edge Infrastructure users have administrator access.
- These items only have a single default option:
 - Compartment
 - Object storage namespace
 - Availability domain
 - Region
 - Tenancy
 - User group
- These Oracle Cloud Infrastructure features are not supported (and not limited to) on Roving Edge Infrastructure devices:
 - Tagging
 - Moving resources to a different compartment (only a single default compartment is available)
 - Object storage replication
 - Object storage retention rules
 - Object storage bucket re-encryption
 - iSCSI block volumes (default is paravirtualized)
 - Getting namespace metadata details

Tagging Resources

Apply tags to your Roving Edge Infrastructure resources to help organize them according to your business needs. You can apply tags at the time you create a resource, or you can update the resource later with the wanted tags. For general information about applying tags, see [Resource Tags](#).

Contacting Oracle Support

Oracle provides various methods to help you in using its products. See [Open a Support Ticket](#) for more information.

Viewing a PDF of this Guide

Click the following link to display a PDF of the *Roving Edge Infrastructure Developer and User Guide* that you can save to your local computer.

[Roving Edge Infrastructure Developer and User Guide](#)

Note:

You can view the PDF file offline. However, it contains links to other Oracle Cloud Infrastructure documentation that requires an internet connection to view.

Concepts

Describes Roving Edge Infrastructure concepts related to its features and functionality.

Be familiar with these concepts before setting up and using your Roving Edge Infrastructure service and devices.

General

- **Oracle Cloud Infrastructure:** The Infrastructure as a Service (IaaS) platform within which the Roving Edge Infrastructure and the other services operate.
- **Oracle Cloud Infrastructure Console:** The web browser-based user interface for interacting with Oracle Cloud Infrastructure.
- **Command Line Interface:** The method of running the Oracle Cloud Infrastructure service features and functionality using text-based commands from a command prompt window.
- **API:** The method of running Oracle Cloud Infrastructure service features and functionality programmatically application programming interface (API) commands.
- **Roving Edge Infrastructure Device Console:** The web browser-based user interface for interacting with your Roving Edge Infrastructure device.

Roving Edge Infrastructure

The following resources and concepts are related to the Roving Edge Infrastructure service and Roving Edge Infrastructure devices.

- **Roving Edge Infrastructure:** The Oracle Cloud Infrastructure service that allows you to operate cloud-based workloads outside of the data center.
- **Roving Edge device (RED):** A high-powered and portable server that can run core IaaS services optimized for remote computing and storage.
- **Roving Edge Ultra (Ultra):** A single battery-powered Roving Edge Infrastructure device capable of being carried by an individual. Ultra provides a highly-portable and rugged edge computing device you can use in indoor and outdoor environments. The device requires minimal protection from the elements, and is able to operate without consistent access to power. Ultra has less storage and computing capabilities than a traditional RED.
- **Provisioning:** The process of loading the required data onto the REDs from the Oracle Cloud Infrastructure compartment and buckets you specify.
- **Node:** The Roving Edge Infrastructure service resource that represents a single RED or Roving Edge Ultra device. See [Roving Edge Device Nodes](#) and [Roving Edge Ultra Nodes](#).
- **Workload:** The object storage bucket or compute custom image that is being provisioned from your Oracle Cloud Infrastructure tenancy to your REDs. See the topic for attaching a workload to your particular Roving Edge Infrastructure device node, for example, [Attaching a Workload to Roving Edge Device Node](#).
- **Data Sync:** Transmission of object storage data between buckets on your Roving Edge Infrastructure devices and your Oracle Cloud Infrastructure tenancy. This update allows you to synchronize data between the RED and Oracle Cloud Infrastructure cloud, and perform software updates. See [Data Sync Tasks](#).
- **Device Software Version Management:** The process of updating the operating system version of your device to a later version. You can also revert your device software to the previously-installed version. See [Device Software Versions](#).

Identity and Access

The following identity and access resources have been optimized for use with Roving Edge Infrastructure:

- **User:** A user account that can access Roving Edge Infrastructure device features and functionality. All users have Administrator privileges. See [Users](#).
- **Group:** A collection of users. Features and functionality applied to a group affects all member users. Roving Edge Infrastructure device nodes only use a single default group. You can't create more groups. See [User Groups](#) on page 180.
- **Policies:** A document that specifies who can access which resources, and how. Access is granted at the group and compartment level, which means you can write a policy that gives a group a specific type of access within a specific compartment, or to the tenancy itself. See [Policies for Managing Roving Edge Infrastructure](#) on page 62.

Compute Virtual Machine

The following compute virtual machine (VM) resources have been optimized for use with Roving Edge Infrastructure:

- **Instance:** A virtual machine (VM) host running in a RED. See [Instances](#).
- **Image:** A template of a virtual hard drive. The image determines the operating system and other software for an instance. See [Images](#).
- **Shape:** A template that determines the number of CPUs, amount of memory, and other resources that are allocated to an instance.
- **Boot Volume:** A detachable boot volume device that contains the image used to boot a compute instance. See [Boot Volumes](#).
- **Console History Capture:** The capture of Serial Console data for an instance. The data is useful for checking the status of the instance or diagnosing problems. See [Console History Capture](#).

Object Storage

The following object storage resources have been optimized for use with Roving Edge Infrastructure:

- **Bucket:** A repository for storing objects in a compartment within an object storage namespace. See [Buckets](#).
- **Object:** A file or unstructured data you upload to a bucket. See [Objects](#).

Block Storage

The following block storage resources have been optimized for use with Roving Edge Infrastructure:

- **Block Volume:** A detachable block storage device that allows you to dynamically expand the storage capacity of an instance. See [Block Volumes](#).

Virtual Networking

The following virtual networking resources have been optimized for use with Roving Edge Infrastructure:

- **Virtual Cloud Network (VCN):** A virtual, private network that you set up in Oracle data centers. See [Virtual Cloud Networks](#).
- **Subnet:** Subdivisions you define in a VCN (for example, 10.0.0.0/24 and 10.0.1.0/24). Subnets contain virtual network interface cards (VNICs), which attach to instances. See [Subnets](#).

Roving Edge Infrastructure Device Specifications

Describes the hardware and port specifications for Roving Edge Infrastructure devices.

Hardware

The following table lists the hardware specifications of the Roving Edge Infrastructure devices. Specifications are for the maximum configuration.

	Roving Edge Device	Roving Edge Device – Compute Shape	Roving Edge Device – GPU Shape	Roving Edge Device – Storage Shape	Roving Edge Ultra
Shape Name	RED.GPU.1.RX1.40	RED.2.56	RED.2.56.GPU	RED.2.56.STG	ULTRA.USB.1.RX2.12
Object, Block, and Filesystem Storage	61 TB raw	4 x 15.38 TB SSDs providing: • raw: 61.5 TB	4 x 15.38 TB SSDs providing: • raw: 61.5 TB	8 x 15.38 SSDs providing: • raw: 123 TB	7.68 TB raw Removable NVMe-based

	Roving Edge Device	Roving Edge Device – Compute Shape	Roving Edge Device – GPU Shape	Roving Edge Device – Storage Shape	Roving Edge Ultra
		<ul style="list-style-type: none"> usable: 54.4 TB (49.8 TiB) 	<ul style="list-style-type: none"> usable: 54.4 TB (49.8 TiB) 	<ul style="list-style-type: none"> usable: 108.8 TB (99 TiB) 	Ignition Key (512 GB) for added security which contains the Roving Edge Infrastructure device operating system and the keys to decrypt the data drive.
Available OCPU	32	48	48	48	8
Usable Memory available for VMs	390 GB DDR4-2933	384 GB	384 GB	384 GB	64 GB DDR4-2400
GPU	NVIDIA(R) Tesla(R) T4 GPU 2650 cudas cores, 320 sensor cores	N/A	3x NVIDIA Corporation AD104GL [L4]	N/A	No integrated GPU. Supports up to 2 Intel Movidius VPUs via USB
CPU	2 x Intel(R) Xeon(R) CPUs Gold 6230T @ 2.1Ghz, 40 total cores	1x Intel 8480+ Sapphire Rapids, 56C, 350W	1x Intel 8480+ Sapphire Rapids, 56C, 350W	1x Intel 8480+ Sapphire Rapids, 56C, 350W	Intel(R) Xeon(R) CPU D-1559 @ 1.50GHz, 12 total cores
Networking	2x10GbE (1 active)	3x Quad port Intel Corporation Ethernet Controller X710 for 10GBASE-T	1x Quad port Intel Corporation Ethernet Controller X710 for 10GBASE-T	1x Quad port Intel Corporation Ethernet Controller X710 for 10GBASE-T	2x1GbE (1 active)
Security	TPM, Trenchboot SecureBoot, physical tamper evidence	TPM, Trenchboot SecureBoot, physical tamper evidence, chassis intrusion detection	TPM, Trenchboot SecureBoot, physical tamper evidence, chassis intrusion detection	TPM, Trenchboot SecureBoot, physical tamper evidence, chassis intrusion detection	TPM, Trenchboot SecureBoot, physical tamper evidence Removable NVMe-based Ignition Key (512 GB) for added security which contains the Roving Edge Infrastructure device operating system and the

	Roving Edge Device	Roving Edge Device – Compute Shape	Roving Edge Device – GPU Shape	Roving Edge Device – Storage Shape	Roving Edge Ultra
					keys to decrypt the data drive.
Dimensions	System: 20" L x 17" W x 3.5" H Rugged Case: 38" L x 23.6" W x 11.8" H	System: 2U – 18.11" L x 16.93 W x 3.46 H Rugged Case: 3U – 35.5" L x 23.8" W x 11.4" H	System: 2U – 18.11" L x 16.93 W x 3.46 H Rugged Case: 3U – 35.5" L x 23.8" W x 11.4" H	System: 2U – 18.11" L x 16.93 W x 3.46 H Rugged Case: 3U – 35.5" L x 23.8" W x 11.4" H	7.4" L x 6.3" W x 2" H without battery 7.4" L x 7.95" W x 2" H with battery pack
Weight	33.6 lbs (15.24 Kg) without rugged case 82.6 lbs (37.47 Kg) with rugged case combined weight	35 lbs (15.9 Kg) without rugged case 91.1 lbs (41.32 Kg) with rugged case combined weight	35 lbs (15.9 Kg) without rugged case 91.1 lbs (41.32 Kg) with rugged case combined weight	35 lbs (15.9 Kg) without rugged case 91.1 lbs (41.32 Kg) with rugged case combined weight	3.75 lbs (1.7 Kg) without battery 4.80 lbs (2.18 kg) with battery pack
Power Output	850 W	1100 W	1100 W	1100 W	55 W
Input Voltage	100 - 240VAC	100 - 240VAC	100 - 240VAC	100 - 240VAC	9 - 36VDC
Battery Options	N/A	N/A	N/A	N/A	Voyager1+ (120 W power output with 65 Wh battery backup power)
80 PLUS Standard	80 PLUS Platinum	80 PLUS Titanium	80 PLUS Titanium	80 PLUS Titanium	
Connector Type	C14	C14	C14	C14	
Compliance and Certs	FIPS 140-2 Level 2 MIL-STD-810G MIL-STD-461G MIL-STD-1472H MIL-STD-1474E	FIPS 140-2 level 2 (TPM) MIL-STD-810H MIL-STD-461G	FIPS 140-2 level 2 (TPM) MIL-STD-810H MIL-STD-461G	FIPS 140-2 level 2 (TPM) MIL-STD-810H MIL-STD-461G	FIPS 140-2 Level 2 MIL-STD-810G/H MIL-STD-461F
Operating Temp Range	0 C to 43 C (-5 C to 65 C storage)	0°C to +50°C	0°C to +50°C	0°C to +50°C	-20 C to 50 C (-40 C to 85 C storage)
Noise Level	68.6 - 73.7 dB (at 25 C ambient)	56.2 dbA (at 25C ambient)	56.2 dbA (at 25C ambient)	56.2 dbA (at 25C ambient)	< 60 dB

Safety and Compliance Resources

For safety and compliance information, refer to the following documents.

[Oracle Engineered System Safety and Compliance Guide](#)

[Oracle Engineered System Safety and Compliance Guide \(Nordic\)](#)

Self-Encryption

Flash storage devices used in Roving Edge Device and Roving Edge Ultra are instant secure erase (ISE) drives. ISE drives behave like full disk encryption (FDE) drives in that the data is encrypted with a hardware key when written to disk, and then decrypted when the data is read from the disk. When the Crypto erase command is sent to the drive, the encryption/decryption key is overwritten, preventing the stored data from being decrypted.

The TPM cryptographic modules used in Roving Edge Devices and Roving Edge Ultra devices are FIPS 140-2 certified.

Tamper-Evident Seals

Oracle applies, maintains, and tracks serialized tamper-evident seals on Roving Edge Device and Roving Edge Ultra. A broken, missing, or damaged label provides a visual indication of a potential hardware breach. Tamper-evident seals aren't FIPS 140-2 certified.

Ultra Battery Options

The following battery options are available for use with Roving Edge Ultra devices:

- Modular stackable form-factor integrated 75Wh module:
 - Directly attaches to the chassis.
 - Provides up to 1 hour of operation per battery at its maximum CPU load.
 - Has a 60W output.

Service Ports

Each Roving Edge Infrastructure device supports a single IP and exposes its services through the following unique ports:

Service	Port
Identity	12050
Authorization	12060
Object Storage Gateway	8019
Virtual Cloud Network (VCN)	18336
Compute	19060
Data Sync	21060, 21061
Monitoring	22060
System Upgrade	23060
Block Storage	5012

Service	Port
Roving Edge Device Console	8015
Etc3	18000

Running CLIs on Device-Hosted Compute Instances

Configure your Roving Edge Infrastructure device to run the command line interface (CLI) on its compute instances.

Follow these guidelines for running CLIs on compute instances hosted by Roving Edge Infrastructure devices.

Note:

The instructions in this topic are for Oracle Linux host computers.

- Have the VM go through the following local IP:
169.254.169.254
- Have the VM refer to the Roving Edge Infrastructure device as `otec-console-local`.
- Employ the following IP Tables rules:

```
{ for i in 19060 8019 12050 21060 22060 23060 22060 12060;do iptables -I
BareMetalInstanceServices -d 169.254.169.254/32 -p tcp -m tcp --dport $i -
m
comment --comment "Rover service access port" -j ACCEPT;done }
```

See [Service Ports](#) for a list of available ports.

Roving Edge Infrastructure Country Support

Describes how Roving Edge Infrastructure and its devices are supported on a country and regional basis.

Supported Regions for Roving Edge Infrastructure

The Roving Edge Infrastructure service is supported in the following regions:

Region Name	Region Identifier	Region Location	Region Key	Realm Key
US East (Ashburn)	us-ashburn-1	Ashburn, VA	IAD	OC1
Germany Central (Frankfurt)	eu-frankfurt-1	Frankfurt, Germany	FRA	OC1
UK South (London)	uk-london-1	London, United Kingdom	LHR	OC1
Singapore (Singapore)	ap-singapore-1	Singapore, Singapore	SIN	OC1
US Gov West (Phoenix)	us-luke-1	Phoenix, AZ	LUF	OC2
US DoD West (Phoenix)	us-gov-phoenix-1	Phoenix, AZ	TUS	OC3

Countries Where You Can Ship Devices

The following table lists those countries where you can ship Roving Edge Infrastructure devices, and their associated provisioning regions. Note the following:

- **Yes** - Shipping to the destination country is available without restrictions.
- **Yes with restrictions** - Shipping to the destination country is available with restrictions. Contact your account representative for more information.
- **No** - Shipping to the destination country is not available.
- **TBD** - Shipping to the destination country has not yet been determined. Contact your account representative for more information.

Countries Where You Can Ship Devices

Country	US-Ashburn (IAD)	EU-Frankfurt (FRA)	UK-London (LHR)
Afghanistan	TBD	Yes with restrictions	No
Aland Islands	TBD	Yes with restrictions	No
Albania	TBD	Yes with restrictions	No
Algeria	TBD	Yes with restrictions	No
American Samoa	TBD	Yes with restrictions	No
Andorra	TBD	Yes with restrictions	No
Angola	TBD	Yes with restrictions	No
Anguilla	TBD	Yes with restrictions	No
Antigua And Barbuda	TBD	Yes with restrictions	No
Argentina	TBD	Yes with restrictions	No
Armenia	TBD	Yes with restrictions	No
Australia	Yes	Yes with restrictions	Yes with restrictions
Austria	Yes	Yes	Yes with restrictions
Azerbaijan	TBD	Yes with restrictions	No
Bahamas	TBD	Yes with restrictions	No
Bahrain	TBD	Yes with restrictions	No
Bangladesh	TBD	Yes with restrictions	No
Barbados	TBD	Yes with restrictions	No
Belarus	No	No	No
Belgium	Yes	Yes	Yes with restrictions
Belize	TBD	Yes with restrictions	No
Benin	TBD	Yes with restrictions	No
Bermuda	TBD	Yes with restrictions	No
Bhutan	TBD	Yes with restrictions	No
Bolivia	TBD	Yes with restrictions	No
Bosnia And Herzegovina	TBD	Yes with restrictions	No
Botswana	TBD	Yes with restrictions	No
Brazil	No	Yes with restrictions	No
Brunei Darussalem	TBD	Yes with restrictions	No
Bulgaria	Yes	Yes	Yes with restrictions

Country	US-Ashburn (IAD)	EU-Frankfurt (FRA)	UK-London (LHR)
Burkina Faso	TBD	Yes with restrictions	No
Burundi	TBD	Yes with restrictions	No
Cambodia	TBD	Yes with restrictions	No
Cameroon	TBD	Yes with restrictions	No
Canada	Yes	Yes with restrictions	Yes with restrictions
Cape Verde	TBD	Yes with restrictions	No
Cayman Islands	TBD	Yes with restrictions	No
Central African Republic	TBD	Yes with restrictions	No
Ceuta And Melilla	TBD	Yes with restrictions	No
Chad	TBD	Yes with restrictions	No
Chile	TBD	Yes with restrictions	No
China	No	Yes with restrictions	No
Colombia	TBD	Yes with restrictions	No
Comoros	TBD	Yes with restrictions	No
Congo	TBD	Yes with restrictions	No
Costa Rica	TBD	Yes with restrictions	No
Cote D'Ivoire	TBD	Yes with restrictions	No
Croatia	Yes	Yes	Yes with restrictions
Cuba	No	No	No
Cyprus	Yes	Yes	Yes with restrictions
Czech Republic	Yes	Yes	Yes with restrictions
Democratic Republic Of The Congo	TBD	Yes with restrictions	No
Denmark	Yes	Yes	Yes with restrictions
Djibouti	TBD	Yes with restrictions	No
Dominica	TBD	Yes with restrictions	No
Dominican Republic	TBD	Yes with restrictions	No
East Timor	TBD	Yes with restrictions	No
Ecuador	TBD	Yes with restrictions	No
Egypt	TBD	Yes with restrictions	No
El Salvador	TBD	Yes with restrictions	No
Equatorial Guinea	TBD	Yes with restrictions	No
Eritrea	TBD	Yes with restrictions	No
Estonia	Yes	Yes	Yes with restrictions
Eswatini	TBD	Yes with restrictions	No
Ethiopia	TBD	Yes with restrictions	No

Country	US-Ashburn (IAD)	EU-Frankfurt (FRA)	UK-London (LHR)
Faroe Islands	TBD	Yes with restrictions	No
Federated States Of Micronesia	TBD	Yes with restrictions	No
Fiji	TBD	Yes with restrictions	No
Finland	Yes	Yes	Yes with restrictions
France	Yes	Yes	Yes with restrictions
French Polynesia	TBD	Yes with restrictions	No
Gabon	TBD	Yes with restrictions	No
Gambia	TBD	Yes with restrictions	No
Georgia	TBD	Yes with restrictions	No
Germany	Yes	Yes	Yes with restrictions
Ghana	TBD	Yes with restrictions	No
Gibraltar	TBD	Yes with restrictions	No
Greece	Yes	Yes	Yes with restrictions
Greenland	TBD	Yes with restrictions	No
Grenada	TBD	Yes with restrictions	No
Guam	TBD	Yes with restrictions	No
Guatemala	TBD	Yes with restrictions	No
Guernsey	TBD	Yes with restrictions	No
Guinea	TBD	Yes with restrictions	No
Guinea-Bissau	TBD	Yes with restrictions	No
Guyana	TBD	Yes with restrictions	No
Haiti	TBD	Yes with restrictions	No
Honduras	TBD	Yes with restrictions	No
Hong Kong	Yes	Yes with restrictions	No
Hungary	Yes	Yes	Yes with restrictions
Iceland	TBD	Yes with restrictions	No
India	No	Yes with restrictions	No
Indonesia	TBD	Yes with restrictions	No
Iran	No	No	No
Iraq	TBD	Yes with restrictions	No
Ireland	Yes	Yes	Yes with restrictions
Israel	No	Yes with restrictions	No
Italy	Yes	Yes	Yes with restrictions
Jamaica	TBD	Yes with restrictions	No
Japan	Yes	Yes with restrictions	Yes with restrictions

Country	US-Ashburn (IAD)	EU-Frankfurt (FRA)	UK-London (LHR)
Jersey	TBD	Yes with restrictions	No
Jordan	TBD	Yes with restrictions	No
Kazakhstan	TBD	Yes with restrictions	No
Kenya	TBD	Yes with restrictions	No
Kiribati	TBD	Yes with restrictions	No
Kosovo	TBD	Yes with restrictions	No
Kuwait	TBD	Yes with restrictions	No
Kyrgyzstan	TBD	Yes with restrictions	No
Laos Peoples Democratic Republic	TBD	Yes with restrictions	No
Latvia	Yes	Yes	Yes with restrictions
Lebanon	TBD	Yes with restrictions	No
Lesotho	TBD	Yes with restrictions	No
Liberia	TBD	Yes with restrictions	No
Libya	TBD	Yes with restrictions	No
Liechtenstein	TBD	Yes with restrictions	Yes with restrictions
Lithuania	Yes	Yes	Yes with restrictions
Luxembourg	Yes	Yes	Yes with restrictions
Madagascar	TBD	Yes with restrictions	No
Malawi	TBD	Yes with restrictions	No
Malaysia	TBD	Yes with restrictions	No
Maldives	TBD	Yes with restrictions	No
Mali	TBD	Yes with restrictions	No
Malta	Yes	Yes	Yes with restrictions
Marshall Islands	TBD	Yes with restrictions	No
Mauritania	TBD	Yes with restrictions	No
Mauritius	TBD	Yes with restrictions	No
Mexico	Yes	Yes with restrictions	No
Moldova	TBD	Yes with restrictions	No
Monaco	TBD	Yes with restrictions	No
Mongolia	TBD	Yes with restrictions	No
Montenegro	TBD	Yes with restrictions	No
Morocco	TBD	Yes with restrictions	No
Mozambique	TBD	Yes with restrictions	No
Myanmar	TBD	Yes with restrictions	No
Namibia	TBD	Yes with restrictions	No

Country	US-Ashburn (IAD)	EU-Frankfurt (FRA)	UK-London (LHR)
Nauru	TBD	Yes with restrictions	No
Nepal	TBD	Yes with restrictions	No
Netherlands	Yes	Yes	Yes with restrictions
New Caledonia	TBD	Yes with restrictions	No
New Zealand	Yes	Yes with restrictions	Yes with restrictions
Nicaragua	TBD	Yes with restrictions	No
Niger	TBD	Yes with restrictions	No
Nigeria	TBD	Yes with restrictions	No
Niue	TBD	Yes with restrictions	No
North Korea	No	No	No
North Macedonia	TBD	Yes with restrictions	No
Norway	TBD	Yes with restrictions	Yes with restrictions
Oman	TBD	Yes with restrictions	No
Pakistan	TBD	Yes with restrictions	No
Palau	TBD	Yes with restrictions	No
Palestinian Territories	TBD	Yes with restrictions	No
Panama	TBD	Yes with restrictions	No
Papua New Guinea	TBD	Yes with restrictions	No
Paraguay	TBD	Yes with restrictions	No
Peru	Yes	Yes with restrictions	No
Philippines	TBD	Yes with restrictions	No
Poland	Yes	Yes	Yes with restrictions
Portugal	Yes	Yes	Yes with restrictions
Puerto Rico	TBD	Yes with restrictions	No
Qatar	TBD	Yes with restrictions	No
Romania	Yes	Yes	Yes with restrictions
Russia	No	No	No
Rwanda	TBD	Yes with restrictions	No
Saint Lucia	TBD	Yes with restrictions	No
San Marino	TBD	Yes with restrictions	No
Sao Tome + Principe	TBD	Yes with restrictions	No
Saudi Arabia	No	Yes with restrictions	No
Senegal	TBD	Yes with restrictions	No
Serbia	TBD	Yes with restrictions	No
Seychelles	TBD	Yes with restrictions	No
Sierra Leone	TBD	Yes with restrictions	No

Country	US-Ashburn (IAD)	EU-Frankfurt (FRA)	UK-London (LHR)
Singapore	Yes	Yes with restrictions	No
Slovakia	Yes	Yes	Yes with restrictions
Slovenia	Yes	Yes	Yes with restrictions
Solomon Islands	TBD	Yes with restrictions	No
Somalia	TBD	Yes with restrictions	No
South Africa	Yes with restrictions	Yes with restrictions	No
South Korea	No	Yes with restrictions	No
South Sudan	TBD	Yes with restrictions	No
Spain	Yes	Yes	Yes with restrictions
Sri Lanka	TBD	Yes with restrictions	No
St. Croix	TBD	Yes with restrictions	No
St. Eustatius	TBD	Yes with restrictions	No
St. Kitts And Nevis	TBD	Yes with restrictions	No
St. Maarten	TBD	Yes with restrictions	No
St. Vincent + Grenadines	TBD	Yes with restrictions	No
Sudan	TBD	Yes with restrictions	No
Suriname	TBD	Yes with restrictions	No
Sweden	TBD	Yes	Yes with restrictions
Switzerland	Yes	Yes with restrictions	Yes with restrictions
Syria	No	No	No
Tahiti	TBD	Yes with restrictions	No
Taiwan	Yes	Yes with restrictions	No
Tajikistan	TBD	Yes with restrictions	No
Tanzania	TBD	Yes with restrictions	No
Thailand	TBD	Yes with restrictions	No
Togo	TBD	Yes with restrictions	No
Tonga	TBD	Yes with restrictions	No
Trinidad And Tobago	TBD	Yes with restrictions	No
Tunisia	TBD	Yes with restrictions	No
Turkey	No	Yes with restrictions	No
Turkmenistan	TBD	Yes with restrictions	No
Tuvalu	TBD	Yes with restrictions	No
Uganda	TBD	Yes with restrictions	No
Ukraine	No	Yes with restrictions	No
United Arab Emirates	Yes	Yes with restrictions	No
United Kingdom	Yes	Yes	Yes

Country	US-Ashburn (IAD)	EU-Frankfurt (FRA)	UK-London (LHR)
United States	Yes	Yes with restrictions	Yes with restrictions
Uruguay	TBD	Yes with restrictions	No
Uzbekistan	TBD	Yes with restrictions	No
Vanuatu	TBD	Yes with restrictions	No
Vatican City State	TBD	Yes with restrictions	No
Venezuela	No	No	No
Vietnam	TBD	Yes with restrictions	No
Western Samoa	TBD	Yes with restrictions	No
Yemen	TBD	Yes with restrictions	No
Zambia	TBD	Yes with restrictions	No
Zimbabwe	TBD	Yes with restrictions	No

Service Limits for Roving Edge Infrastructure

Review the service limits for the Roving Edge Infrastructure service and its various devices.

The Roving Edge Infrastructure service has the following limits:

- **Roving Edge Infrastructure devices:** You can request either a single Roving Edge Infrastructure device (either a Roving Edge Device (RED) or a Roving Edge Ultra (Ultra)).
- **Object size:** You can request files up to 5 TB to be provisioned onto a Roving Edge Device. Files larger than 5 TB are skipped in the import process.

Note:

Consider the specific device storage limitations when adding workloads and data to your order.

- **File name length:** You can request files with names of up to 1024 characters for upload into your Object Storage bucket.

Requesting Devices

Learn how to request your Roving Edge Infrastructure devices in Oracle Cloud Infrastructure.

Note:

- Determine your Roving Edge Infrastructure device storage capacity when determining the number of devices to request. See [Device Usage Guidelines](#) for more information.
- Your tenancy must be in an Oracle Cloud Infrastructure region that supports Roving Edge Infrastructure. See [Supported Regions](#) for more information.

Important:

Ordering Oracle Roving Edge Infrastructure devices requires important terms and conditions to be understood and acknowledged before taking possession. Confirm that these terms and conditions have been included as part of your Oracle Cloud agreement. After Oracle validates your request,

your Roving Edge Infrastructure devices are provisioned and available for your possession.

Device Ordering Requirements

Describes Oracle Cloud Infrastructure account requirements that you must meet to order Roving Edge Infrastructure devices.

You're required to have an Oracle Cloud Infrastructure account to request Roving Edge Infrastructure devices. The account must be a UCM contract or Funded Allocation Model (FAM). It can't be Pay As You Go (PAYG) or Free Tier. If you currently have one of these unsupported Oracle Cloud Infrastructure accounts, contact your Account Team for instructions on how to upgrade to a supported Oracle Cloud Infrastructure account.

You must also have a tenancy in an Oracle Cloud Infrastructure Realm and Region where Roving Edge Infrastructure is available. The following table list the Roving Edge Infrastructure Realms and Regions in which you can order Roving Edge Infrastructure devices.

OCI Realms and Regions Supporting Roving Edge Infrastructure

Region Name	Region Identifier	Region Location	Region Key	Realm Key
US East (Ashburn)	us-ashburn-1	Ashburn, VA	IAD	OC1
Germany Central (Frankfurt)	eu-frankfurt-1	Frankfurt, Germany	FRA	OC1
UK South (London)	uk-london-1	London, United Kingdom	LHR	OC1
Singapore (Singapore)	ap-singapore-1	Singapore, Singapore	SIN	OC1
US Gov West (Phoenix)	us-luke-1	Phoenix, AZ	LUF	OC2
US DoD West (Phoenix)	us-gov-phoenix-1	Phoenix, AZ	TUS	OC3

The core Oracle public cloud services, including Roving Edge Infrastructure, are available in the following ways:

- **Metered Services:** A pre-paid offering, also referred to as "ala carte" or "committed" offerings. A Metered cloud service is where you are charged based on the actual usage of the service resources on an hourly or monthly basis.
- **Non-metered Services:** A subscription-based offering, also referred to as "standard subscription" or "un-committed" offerings. A Non-metered service is essentially a monthly or annual subscription for a fixed service configuration that you typically cannot change.

The Roving Edge Infrastructure service requires you agree to the Terms and Condition documents for the service. An authorized person in your organization must sign these documents before ordering Roving Edge Infrastructure devices. After the Terms and Conditions are agreed to, your Oracle Cloud Infrastructure tenancy is authorized and entitled to use Roving Edge Infrastructure, including ordering Roving Edge Infrastructure devices.

Roving Edge Devices and Ultra Devices

For ordering Roving Edge devices (RED)s and Roving Edge Ultra devices as UCM metered, refer to the ORACLE CLOUD INFRASTRUCTURE – ORACLE ROVING EDGE INFRASTRUCTURE section in [Oracle PaaS and IaaS Universal Credits Service Descriptions](#).

To configure and use Roving Edge Infrastructure resources, you must have:

- An Annual Commitment or Funded Allocation agreement with a minimum of 120 days remaining on your cloud services period at the time of your order.
- Oracle PaaS and IaaS Universal Credits with a minimum of 30 days of possession.

Terms and Conditions are sent using DocuSign email to the administration buyer of the account to route for signature and return. For any questions or change requests, engage your Account Team.

Request a Device

To request a device you create a device node. Perform one of the following tasks to request a device:

- For Roving Edge Devices, see [Creating a Roving Edge Infrastructure Device Node](#) on page 128.
- For Roving Edge Ultra devices, see [Creating a Roving Edge Ultra Node](#) on page 138.

After you have requested your devices, you must establish the certificate authority (CA). See [Establishing the Certificate Authority](#) for more information.

Viewing Your Request Status

When you complete your request and submit it, you can review the state of the request by viewing the node details. See one of the following sections:

- [Getting a Roving Edge Infrastructure Device Node's Details](#) on page 134
- [Getting a Roving Edge Ultra Node's Details](#) on page 144

Initially, your request has a status of **Pending Approval**. After Oracle approves the node request, the pre-loading on content onto your Roving Edge Infrastructure devices can begin. Your request status changes to **Provisioning**.

How Oracle Provisions Your Request

Provisioning is where Oracle takes your approved node request and performs the following tasks on the Roving Edge Infrastructure devices you are to receive:

- Install the operating system and other host software required by each device.
- Configure encryption on the device's storage.
- Load the image and bucket data specified in the workloads associated with the node request.

Note:

Each Roving Edge Infrastructure device is wiped clean of data using NIST 800-88 standards before provisioning begins.

When provisioning is completed, the Roving Edge Infrastructure devices are delivered to you or made available for pickup at an Oracle facility based on your preferences. Next, you can physically integrate the devices into your computing environment and begin configuration.

What's Next?

After you have completed the tasks associated with requesting your Roving Edge Infrastructure devices, continue on to [Administering Devices](#) on page 37.

Establishing the Certificate Authority for Roving Edge Infrastructure Devices

Describes how to set up a certificate authority to use for your Roving Edge Infrastructure device certificates in Oracle Cloud Infrastructure.

Sign any certificates used by Roving Edge Infrastructure devices with RSA keys. All certificates in the chain (for example, root, subordinate and leaf certificates) should use SHA family signing algorithms and RSA family signing keys. Roving Edge Infrastructure does not support other signing keys such as ECDSA.

See [Managing Certificate Authorities](#) for information on establishing the certificate authority to use with Roving Edge Infrastructure when creating your device node certificates.

Setting Up Oracle Roving Edge Device

Set up the Roving Edge Device Compute, GPU, and Storage shapes at your location, and configure it to connect to your Oracle Cloud Infrastructure tenancy so that it serves as an extension of your tenancy.

Note:

These setup instructions apply to the following device models:

- Roving Edge Device Compute (shape name: **RED.2.56**)
- Roving Edge Device GPU (shape name: **RED2.56.GPU**)
- Roving Edge Device Storage (shape name: **RED.2.56.STG**)

If your Roving Edge Device doesn't support those shapes, use the setup instructions included in the shipping box instead of these instructions.

To display a PDF of this *Roving Edge Device Setup Guide* that you can save to your local computer, click: [Roving Edge Device Setup Guide PDF](#)

Perform the following tasks to set up the Roving Edge Device:

Task	Link
1	Receive and Inspect the Shipment on page 24
2	Remove the Ruggedized Case End-Caps on page 27 or Mount the Device in a Rack on page 29
3	Cable the Roving Edge Device on page 32
4	Set Up Terminal Emulation on page 33
5	Power On the Device on page 34
6	Configure Network Parameters on page 34
7	Unlock the Device on page 35
8	Download the Root CA Certificate on page 36

Related Resources

- [Roving Edge Infrastructure Device Specifications](#)
- Safety and Compliance Resources:
 - [Oracle Engineered System Safety and Compliance Guide](#)
 - [Oracle Engineered System Safety and Compliance Guide \(Nordic\)](#)

What's next?

[Receive and Inspect the Shipment](#) on page 24

Receive and Inspect the Shipment

Carefully inspect the Roving Edge Device shipment before you unpack the shipment.

Important:

Report any damage or concerns to Oracle using a Service Request ticket. See [Getting Help and Contacting Support](#) and [My Oracle Support](#).

Obtain Shipment Details

Perform these steps to gather information you can use to inspect the shipment and ensure a tamper free device.

1. Sign in to your Oracle Cloud Infrastructure (OCI) tenancy.
2. From the console navigation menu, click **Hybrid**, then click **Roving Edge Infrastructure**.
3. Select the compartment for this device.
4. Click **Manage Nodes**.
5. Click the node name to display the details page, and make note of these details:
 - Device request is updated to a *Delivered* status
 - The date and time it was received
 - The serial number

Inspect the Shipment

1. Visually inspect the device shipping container for any damage, tampering, or missing ties before opening it.
2. Compare the serial number that appears on all the security ties with the serial number listed for the device in your tenancy.
3. Unpack and visually inspect the device for any tampering or damage.
4. Ensure that you've received all the shipping kit contents, as shown in the following illustration.

Note:
 The device ships with either a ruggedized case or a rackmounting kit based on what was specified when the device node was created. See [Creating a Roving Edge Infrastructure Device Node](#) on page 128.

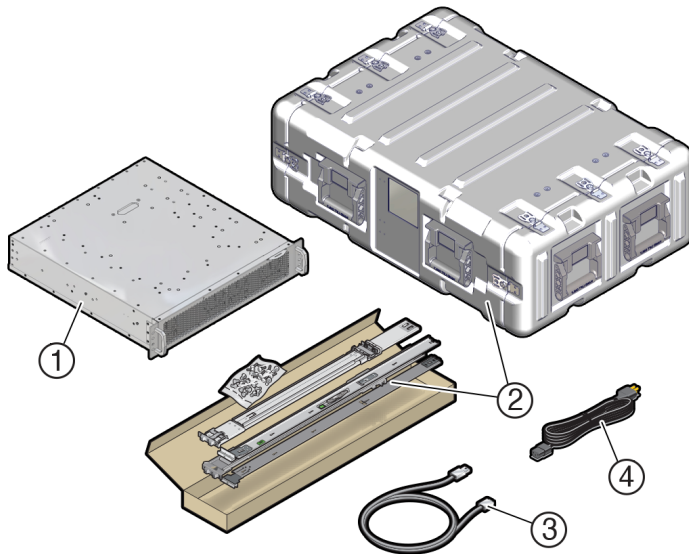

No.	Item
1	Roving Edge Device
2	One of the following: <ul style="list-style-type: none"> • Ruggedized case • Rack mounting kit with the following items: <ul style="list-style-type: none"> • Two mounting brackets inside two slide-rails • 4 M4 screws

No.	Item
3	USB-to-DB-9 serial cable For devices with ruggedized cases, the cable is in a pouch inside the rear of the case.
4	AC power cord For devices with ruggedized cases, the power cord is in a pouch inside the rear of the case.

Roving Edge Device Rear Panel

Use the following illustration to familiarize yourself with the Roving Edge Device.

Note:
If your device is in a ruggedized case, you can view the rear panel after you removed the case end-caps, described in [Remove the Ruggedized Case End-Caps](#) on page 27.

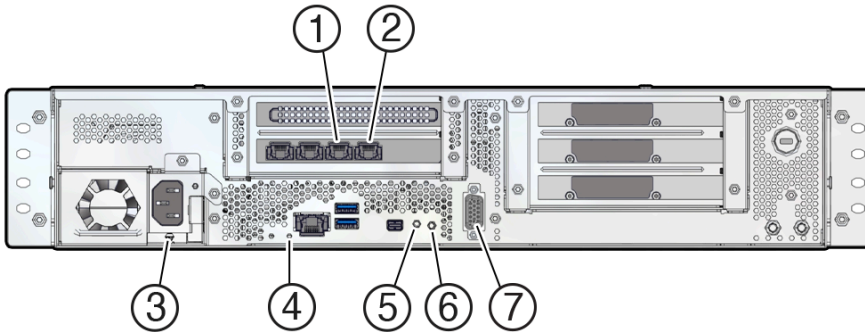

No.	Description
1	Reserved Ethernet port. Don't use.
2	Ethernet ports 2 (left) and 1 (right) *. Can optionally be used for network bonding.
2	Ethernet port 0 is used to connect to your network *.
3	Power receptacle
4	System status LED <ul style="list-style-type: none"> • On – Critical event occurred • Off – Normal
5	Reset button
6	Power switch and LED <ul style="list-style-type: none"> • On – Host is powered on • Off – Host is powered off • Amber – Fault
7	DB-9 serial console port

* To meet MIL-STD-461 Rev G RE102 requirements, all Ethernet network cables attached to the Roving Edge Device must be CAT8 rated.

What's next?

- If your device is inside a ruggedized case, see [Remove the Ruggedized Case End-Caps](#) on page 27.
- If the device isn't in a ruggedized case, install your device in a rack. See [Mount the Device in a Rack](#) on page 29.

Remove the Ruggedized Case End-Caps

If the Roving Edge Device is in a ruggedized case, you must remove the front and rear end-caps to access the cable connectors. The end-caps remain removed during operation.

Caution:

Don't remove the Roving Edge Device from the case. Doing so can damage the device.

Caution:

Leave the end-caps removed during operation to ensure adequate airflow. Reinstall the end-caps only when the device is powered down.

1. On the front and rear of the ruggedized case, find the 16 wing-turn latches.

Note: The rear end-cap has casters.

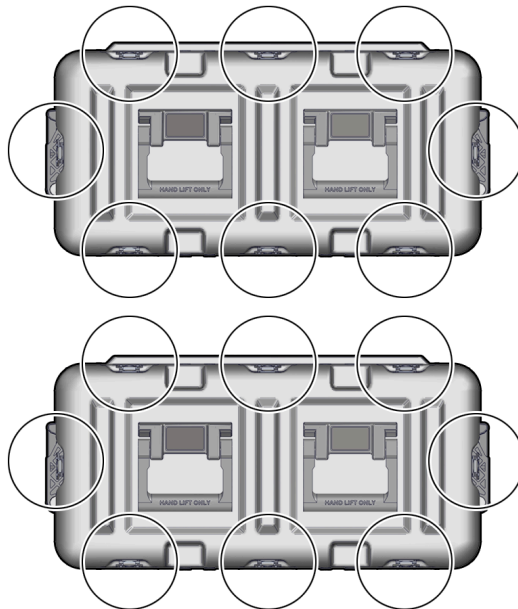

2. Open all 16 wing-turn latches on the front and rear of the case by lifting the latch then turning the latch counterclockwise.

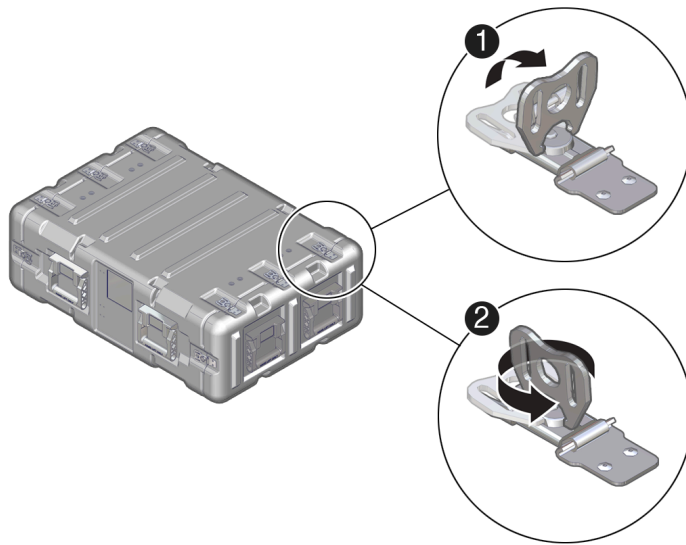

3. Remove the front and rear end-caps.

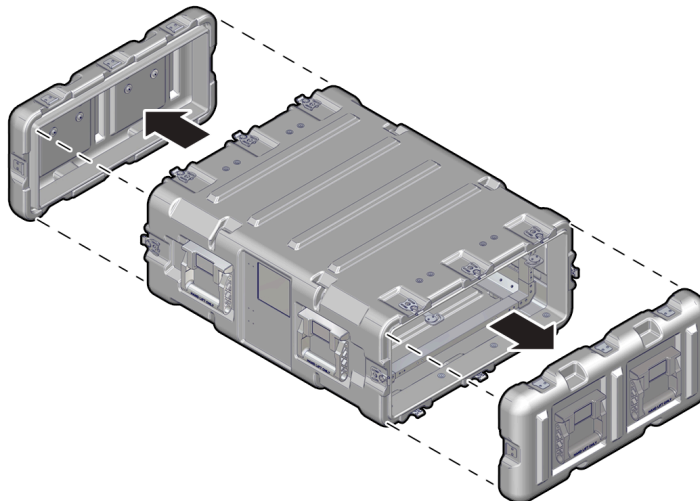

4. Remove the cable pouch, and extend the end-cap hooks.

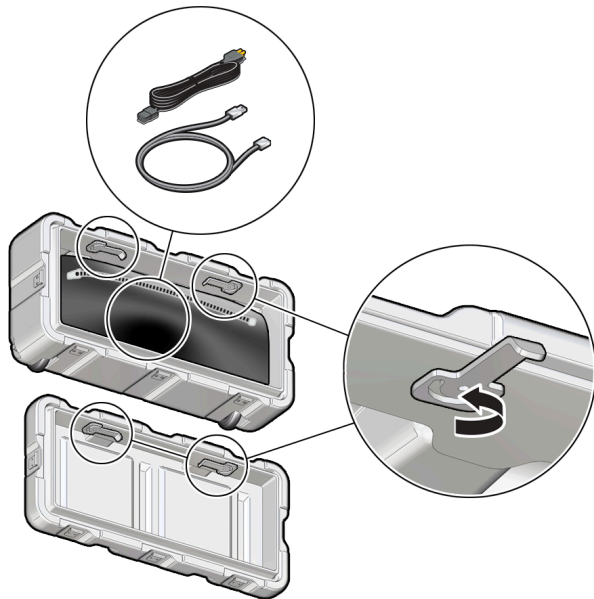

5. Hang the end-caps on the sides of the ruggedized case.

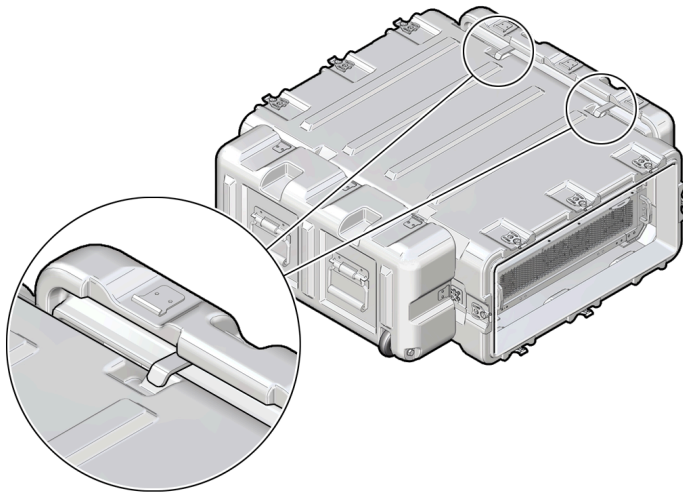

What's next?

[Cable the Roving Edge Device](#) on page 32

Mount the Device in a Rack

Use these instructions if you plan to mount your Roving Edge Device in a standard rack.

The optional rackmount kit can be used to install the device in a four-post, 19-inch standard rack.

Rackmounting the Device

1. Separate the device mounting brackets from the slide-rails.

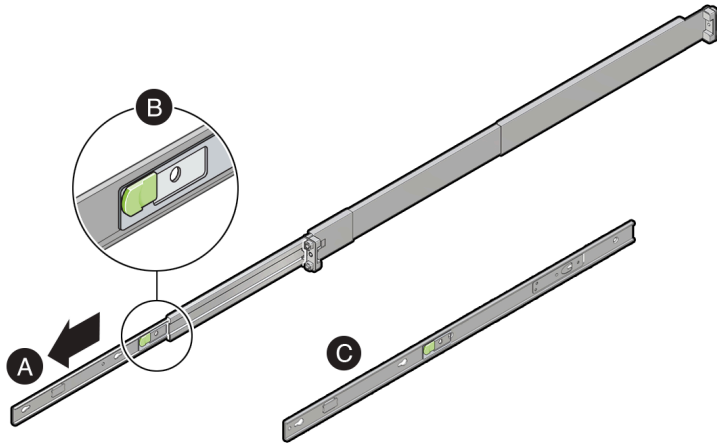

- a. Pull the mounting brackets out of the slide-rail brackets.
 - b. Press the release lever to release the locking mechanism.
 - c. Remove the mounting brackets from side-rails.
2. Attach the mounting brackets to the device.

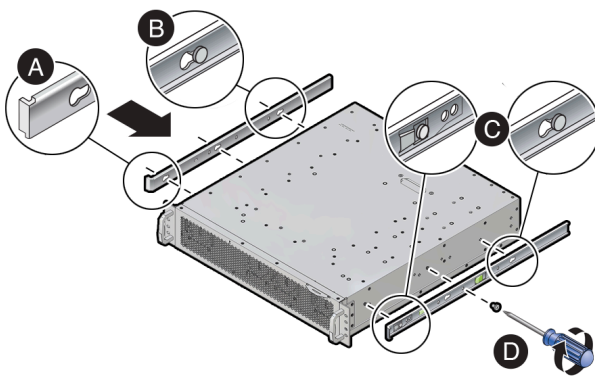

- a. Position the mounting brackets against the device so that the slide-rail stop is at the front of the device.
 - b. Line up the keyhole openings on the mounting bracket with the locating pins on the side of the device.
 - c. Push the mounting brackets forward until they lock in place with an audible click.
 - d. Secure the mounting brackets by installing one M4 screw to each side of the device.
3. Identify the location in the rack where you want to place the device.

Roving Edge Device requires two rack units (2U) of vertical space.

Caution:

To reduce the risk of personal injury, stabilize the rack cabinet, and if available, extend the anti-tilt bar before you install the server.

4. If your rack posts aren't labeled, mark the mounting holes on the front and rear posts to ensure a level installation.
5. Attach the two slide-rails to the rack.

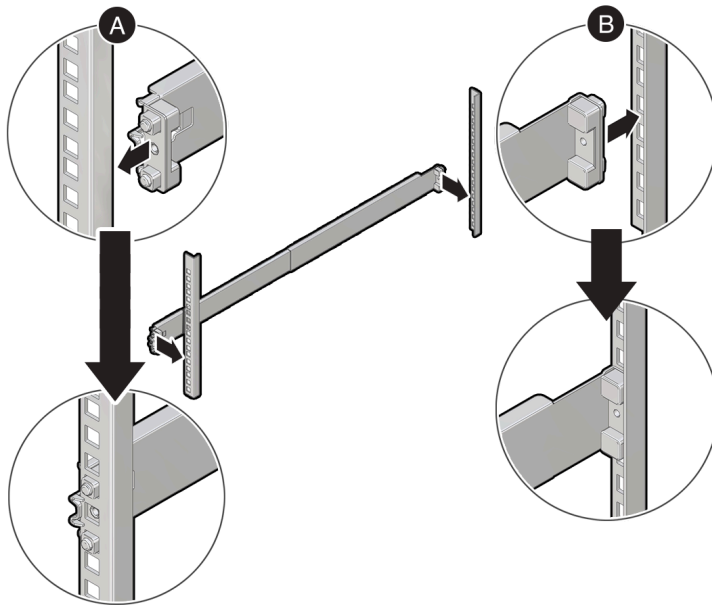

- a. Snap the front slide-rails into the front rack posts.
 - b. Adjust the rear slide-rails to reach the rear rack posts, then snap the slide-rails into the rear rack posts.
6. Install the device into the slide-rails.

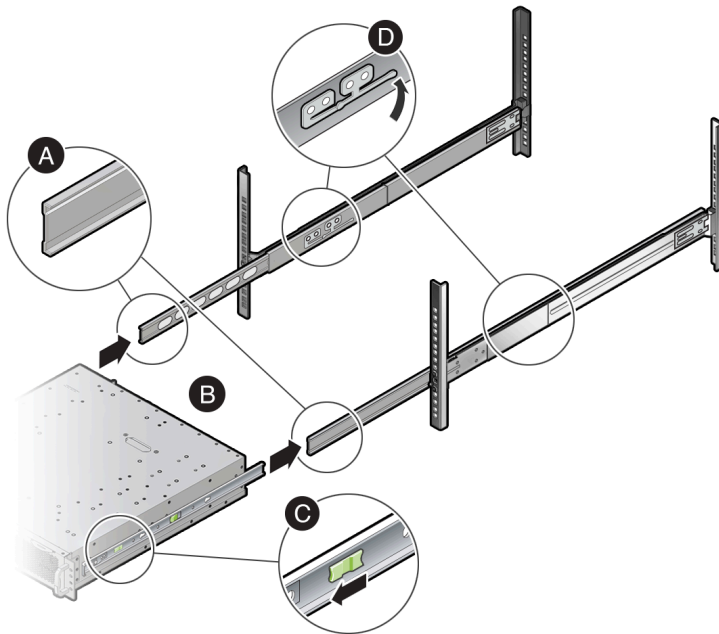

- a. Extend the inner-front slide-rails.
 - b. Slide the mounting brackets into the extended slide-rails until the device is securely supported by the slide-rails, but is extended from the rack.
 - c. Pull the green lever forward to enable the mounting brackets to slide fully into the slide-rails.
 - d. Lift the slide-rail stop lever and push the device completely into the rack.
7. Install two M4 screws to the front of the device.

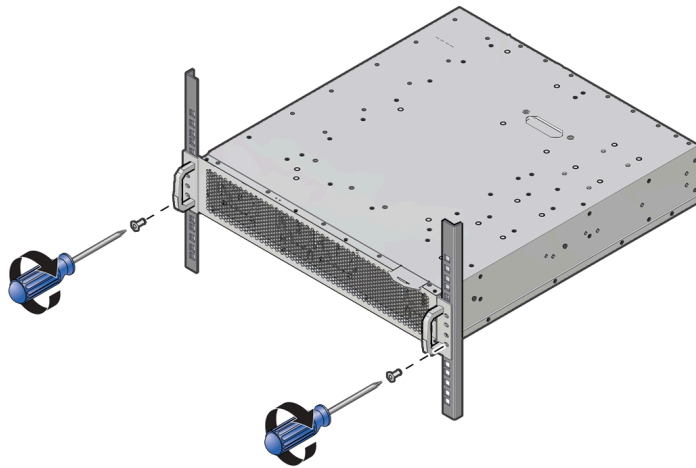

What's next?

[Cable the Roving Edge Device](#) on page 32

Cable the Roving Edge Device

Use the following diagram to locate connectors on the rear of the Roving Edge Device 2 as you connect cables in this procedure.

Note:
To meet MIL-STD-461 Rev G RE102 requirements, all Ethernet network cables attached to the Roving Edge Device must be CAT8 rated.

1. Connect the provided USB-to-DB-9 Ethernet cable from the device DB-9 serial console port to a USB connector on your controlling host, such as a laptop.

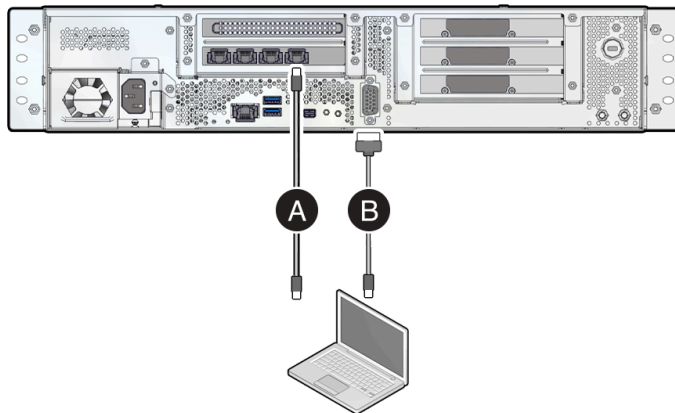

- a. Use a 10GBaseT RJ-45 Ethernet cable to connect the device Ethernet port to your Ethernet switch.
- b. Use the provided USB-to-DB-9 serial cable to connect the device serial port to a laptop.
2. Connect the provided power cord to the device power receptacle and to your power source, but don't power on the device yet.

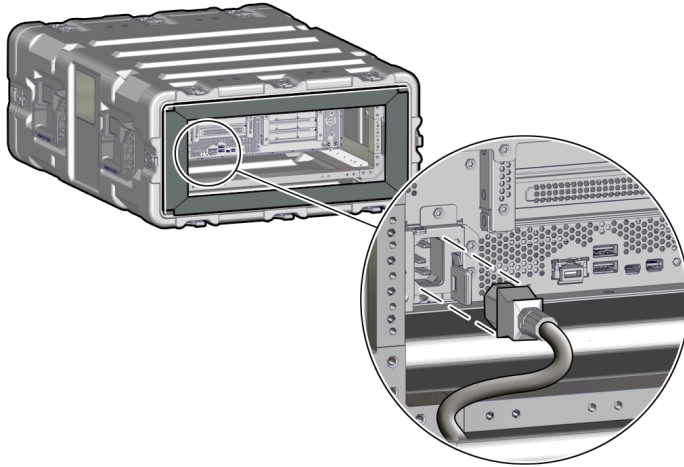

What's next?

[Set Up Terminal Emulation](#) on page 33

Set Up Terminal Emulation

Your initial communication with the Roving Edge Device is made through the serial console that's connected to a controlling host computer, such as a laptop. The controlling host must have terminal emulation software that's configured as described in this section.

We recommend the following terminal emulation software based on your host operating system:

Microsoft Windows: **PuTTY**

Mac OS X: **ZOC** or **screen** (for example: `screen /dev/ttyusbserialX 115200`)

Linux: **PuTTY**, **Minicom**, **screen** (for example: `screen /dev/ttyUSBX 115200`)

1. Based on your host OS, use the appropriate method to ensure that the `p12303` USB driver is installed. This USB driver is required for connectivity to the Roving Edge Device DB-9 serial port.

The USB driver is preinstalled on Oracle Unbreakable Enterprise Kernel. The following command shows that the USB driver is present:

```
[root@localhost ~]# modprobe p12303
[root@localhost ~]# lsmod | grep -i p12303
p12303                24576  0
[root@localhost ~]# modinfo -d p12303
Prolific PL2303 USB to serial adaptor driver
```

If the driver isn't installed, use the appropriate method to install the driver. For example, go to the Microsoft Windows or Apple store to obtain and install the driver.

2. Configure the terminal emulator software settings as follows:
 - Terminal Type: **VT100+**
 - Bits per second: **115200**
 - Data Bits: **8**
 - Parity: **None**
 - Stop Bits: **1**
 - Flow Control: **None**

Note:

With PuTTY, you can't configure all these settings individually. However, you can configure the PuTTY default settings by selecting the Serial connection type and specifying 115200 for the Serial Line baud speed. This configuration is sufficient to use PuTTY as a terminal emulator for the device.

What's next?

[Power On the Device](#) on page 34

Power On the Device

After you've configured your controlling device, power on the device.

1. Power up the device by pressing the power button. See [Roving Edge Device Rear Panel](#) on page 26.

The LED by the power button blinks for a few seconds and then turns solid green.

What's next?

[Configure Network Parameters](#) on page 34

Configure Network Parameters

Configure the Roving Edge Device network settings through your controlling host that's connected to the serial port.

Note:

For a list of serial console commands, see [Operating the Serial Console](#)

1. From the controlling host terminal window, select the **Configure the Network** menu option. The following options are displayed:

- **Set Node IP Settings (Current Node Only):** Set the node IP address, subnet mask, and default gateway.
- **Display Settings:** Show the current network settings.
- **Set Public IP Pool Range for Compute Instances:** Set the external IP address pool for compute instances.

IP addresses are allocated from this pool when an instance is created with public IP address assigned to it.

Important – This operation removes the current external IP address pool, and replaces it with the ranges from the new input.

The best practice is to use a contiguous range of IPs. An ideal range is a CIDR range such as 10.10.0.0 - 10.10.0.15, which corresponds to 10.10.0.0/28, which is what is stored internally.

If you're updating your public IP pool range, none of the IPs in the existing range can be allocated to a compute instance during the operation. The best practice is to ensure all public IPs are dissociated with all compute instances before updating your public IP pool range.

- **Display Public IP Pool Status:** Show the current public IP pool range.
- **Control Network Ports:** Enable or disable network ports.
- **Configure DNS:** Configure the DNS servers for the current node control plane. Reboot the device for the DNS configurations to take effect, if the device is already unlocked.
- **Configure Subnet Gateway:** Configure the gateway for a given subnet. The destination can be the default IGW or a private IP Address. You can perform the following tasks:
 - **Show Configuration:** Show the current subnet gateway configuration. The output shows whether the destination is IGW or a private IP address for each subnet.
 - **Update Configuration:** Update the current subnet gateway configuration. For example:

```
-----
Idx  Subnet CIDR      DNS Label      Gateway
-----
```

```

1    10.0.1.0/24    Subnet-1    10.0.2.2
2    10.0.2.0/24    Subnet-2    IGW
3    10.0.3.0/24    Subnet-3    IGW

```

```

Enter Subnet Index: 1
Enter the gateway (IGW or private IP address) for this subnet:

```

- **Configure NTP:** Perform the following NTP configuration tasks:
 - **Display NTP Configuration:** Configure external NTP servers. For example:

```

Local Time and RTC
Local time: Fri 2022-05-13 04:26:41 UTC
Universal time: Fri 2022-05-13 04:26:41 UTC
RTC time: Fri 2022-05-13 04:26:43
Time zone: UTC (UTC, +0000)
NTP enabled: n/a
NTP synchronized: no
RTC in local TZ: no
DST active: n/a

```

- **Update NTP configuration:** Identify the primary and secondary servers that set up the NTP configuration for the device.
 - **Reset Network:** Reset the network by erasing all the network configurations such as Node IP, Public pool, DNS, NTP, and Gateway.
 - **Help:** Display online help for the **Network Configuration** menu options.
 - **Go Back:** Return to the main serial console menu.
2. Use the menu options to configure the device network parameters according to your network environment. At minimum, configure these parameters:
 - Network settings
 - DNS
 - NTP

What's next?

[Unlock the Device](#) on page 35

Unlock the Device

Roving Edge Device arrives in a locked state. You must unlock the device using an unlock passphrase when you power on the device.

The passphrase was created when you created the device node, as described in [Creating a Roving Edge Infrastructure Device Node](#) on page 128.

Note:

Anytime you reboot the device, it reverts to a locked state. Receiving a `Device is locked` message after trying to connect to an API endpoint is indicative that the device is in a locked state. Unlock the device to proceed.

Note:

If your device is unexpectedly in a locked state, it might have accidentally rebooted. Check that your power connection is steady and not inadvertently causing device reboots.

1. From the serial console **Configure Networking** screen, select **Go Back** to return to the main serial console menu.
2. Select **Unlock Device**.

In the terminal emulator, you're prompted for the passphrase.

3. Enter the unlock passphrase to unlock the device.

The device is unlocked, and the serial console menu is displayed.

What's next?

[Download the Root CA Certificate](#) on page 36

Download the Root CA Certificate

Download the root CA certificate from the Roving Edge Device to your host. The host is the system you plan to use to manage services on the device. The root CA certificate acts as a credential to validate the identity of the host, and enables communication between the device and host.

Use one of the following procedures to download the root CA certificate from a Roving Edge Device to your host.

Linux and Mac OS

1. On your host, use the following command to download the root CA certificate from the device:

```
echo -n | openssl s_client -showcerts -connect <RED_ip_address>:8015 | sed -ne '/-BEGIN CERTIFICATE-/,/-END CERTIFICATE-/p' > redroot.pem
```

2. Based on the OS you're using, perform one of the following actions:
 - a. If you're using a Mac OS system on a Safari or Chrome browser, use the MacOS Keychain. Open the Finder and look for the `redroot.pem` file. Double-click the file and install the certificate.
 - b. If you're using a Linux system on a Chrome browser, go to **Chrome Settings (or Preferences) > Security and Privacy > Security > Manage certificates > Authorities tab > Import > Browse** and choose the `redroot.pem` file in the location where you created it. Next, click **Open** and select the **Trust this certificate for identifying websites** option. The certificate appears in the list of certificate authorities.

Windows

1. Use the following command to download the root CA certificate from a Roving Edge device:

```
execute command - openssl.exe s_client -connect <RED_ip_address>:8015 -showcerts
```

2. Copy and paste the root CA certificate from the browser to Notepad and save the file with the filename `redroot.cer`. The certificate starts with a line containing: `BEGIN CERTIFICATE` and end with the line containing: `END CERTIFICATE`
3. If you're using an Edge or a Chrome browser, perform these steps:
 - a. Add the certificate to the trust store by opening the File Explorer and double-clicking the `redroot.cer` file.
 - b. Install the certificate.
 - c. Place all certificates in the Trusted Root Certificate Authorities folder.

For more information about managing certificates in Oracle Cloud Infrastructure, see [Certificates](#)

What's next?

Go to the online [Roving Edge Infrastructure](#) documentation.

Click the following link to display a PDF of the *Roving Edge Infrastructure Developer and User Guide* that you can save to your local computer.

[Roving Edge Infrastructure Developer and User Guide](#)

Note:

You can view the PDF file offline. However, it contains links to other Oracle Cloud Infrastructure documentation that requires an internet connection to view.

Administering Devices

Describes how to set up your Roving Edge Infrastructure devices.

Follow the instructions in this section to receive, inspect, and configure your Roving Edge Infrastructure devices for use in your environment. Perform the tasks described in this section on each device you receive.

Operating the Serial Console

The Roving Edge Infrastructure device Serial Console contains the following commands:

- **Unlock Device:** Use to unlock the device using an unlock passphrase obtained from the device's node resource in Oracle Cloud Infrastructure. See [Unlock the Device](#) on page 35.
- **Change Passphrase:** Use to update the device's unlocking passphrase. This passphrase is listed in the **Details** section of your node in the OCI Console.
- **Configure Networking:** Use to configure IP address, subnet, and gateway for the device. You can also configure DNS, NTP, and the public IP pool range for Compute VM instances through this command. See [Configure Network Parameters](#) on page 34.
- **Show Status:** Use to display the device software version, lock or unlock status, and other device information.
- **Show System Diagnostics:** Use to display diagnostic information regarding the device's system attributes.
- **Shutdown Device:** Use to shut down the device.
- **Reboot Device:** Use to reboot the device.
- **Enter Safe-Mode:** Contact support before using Safe-Mode, use when the storage is full resulting in write and/or read errors. At this storage capacity level the Compute service and other device operations are suspended. While in safe mode, you can remove items from object storage until the capacity is lower, preferably at 80% or less. See [Avoiding Storage Overages Using Safe Mode](#) on page 38.
- **Exit Safe-Mode:** Use to take the device out of safe mode after you have lowered the device's storage capacity level. See [Avoiding Storage Overages Using Safe Mode](#) on page 38.
- **Shred Key:** Use to destroy or "shred" the master key of your device. Run this command if you believe the device's has been compromised or is unsafe and is likely to be compromised. See [Shredding the Master Key](#)
- **Recover Key:** Use to recover a device whose key has been shredded and return it to service. See [Recovering Your Device after Shredding the Master Key](#).
- **Reset Device:** Use to reset the device, either to factory level (objects in object storage are deleted) or service level (objects in the object storage retained.). See [Resetting Devices](#) on page 38.
- **Advance Menu:** Use to access additional menu commands:
 - **Banner Management:** Use to run various banner tasks. The banner is the default message that appears when you attempt to log into the device. See [Managing the Banner](#) on page 39.
 - **Network Management:** Use to display the status various network-related topics. See [Managing the Network](#) on page 39.
 - **Password Management:** Use to specify the number of user login attempts allowed. See [Managing Your Password](#) on page 40.
- **Node Health:** Use to monitor the storage health in Roving Edge Infrastructure device nodes. Storage health covers following components:
 - Block storage health
 - Object storage health
 - Storage backend services health
 - Disk health

The health of a service on a device node is determined by the following classifications:

- **AVAILABLE:** The service is available, and all components are functional.
- **WARNING:** The service is still functional, but some minor issue is happening and we may need to pay attention.
- **DEGRADED:** The service is partially functional and some components have issues.

- **UNAVAILABLE:** The service is not responding or some components have critical issues which make the service not functional.
- **Diagnostics:** Use to run tasks related to collecting diagnostics data related to Roving Edge Infrastructure device performance. You can collect the diagnostics data and forward it to Oracle for analysis. See [Collecting Device Diagnosis Information](#).
- **Help:** Use to display the online help for the Serial Console.

Resetting Devices

You can reset your Roving Edge Infrastructure device to various levels. Use this feature if your device is not functioning correctly and you cannot recover it using regular troubleshooting operations such as rebooting.

Resetting your device affects its on-device services. If a service has been modified by a system upgrade, resetting the device reverts the service to its original version. All virtual machine (VM) instances, block and boot volumes, network configurations are deleted by resetting your device. The state of IAM service is also removed. The system prompts you for a new root password, and after that the IAM is reinitialized to the blank state with only the root user active.

Object storage contents are not automatically deleted in the same manner as the other services. When you perform a factory reset, you are prompted to select one of the following object storage options:

Your device must be running and connected to your controlling host running terminal emulation software such as PuTTY to reset the device. See [Set Up Terminal Emulation](#) on page 33 for more information.

1. Using terminal emulation, select the **Reset Device** menu option. The following options appear:
 - **Factory Reset:** This option deletes all VM instances, boot volumes and block volumes on the device. All system upgrades are rolled back. All user information is deleted and a single root user is created. All objects in the object storage are deleted, including VM images and audit logs.
 - **Service Reset:** This option deletes all VM instances, boot volumes and block volumes on the device. All user information is deleted and a single root user is created. Objects in the object storage remain untouched.
 - **Network Reset:** This option resets the network configuration values to the factory default for items such as DNS servers. User-configured values, such as IP addresses are removed. See [Configure Network Parameters](#) on page 34 after you reset the network to reestablish your networking.
2. The following options appear:
3. Enter the device passphrase when prompted. See [Unlock the Device](#) on page 35 for more information.
4. Enter the new user root password when prompted.

Object storage contents are not automatically deleted in the same manner as the other services. When you perform a factory reset, you are prompted to select one of the following object storage options:

- **Preserve objects:** Deletes all VM instances, boot volumes and block volumes on this device. All system upgrades are rolled back. All user information is deleted and a single root user is created. All objects in object storage remain untouched.
- **Do not preserve objects:** Deletes all VM instances, boot volumes and block volumes on this device. All system upgrades are rolled back. All user information is deleted and a single root user is created. All objects in object storage are deleted.

Avoiding Storage Overages Using Safe Mode

We recommend keeping the object storage capacity on your Roving Edge Infrastructure devices at 80% or less.

When the storage is full, read and write errors can occur and storage operations cease. If this occurs, place your device in Safe Mode and remove items from object storage until the capacity is lower, preferably at 80% or less.

Your device must be running and connected to your controlling host running terminal emulation software such as PuTTY to place the device in Safe Mode. See [Set Up Terminal Emulation](#) on page 33 and [Operating the Serial Console](#) on page 37 for more information.

1. Using terminal emulation, select the **Enter Safe-Mode** menu option.

2. Remove items from object storage. We recommend keeping object storage levels at 80% or less.
3. Select **Exit Safe-Mode**. After the Roving Edge Infrastructure device determines that its object storage capacity is below the 95% level, it returns to normal operation.

See [Roving Edge Infrastructure Device Monitoring](#) on page 148 for more information about monitoring and calculating object storage capacity.

Managing the Banner

The serial device banner is a message that is displayed each time you attempt to log in to the device. Typically this message contains information regarding the nature of the device, including any rules and restrictions for its use. By default, the banner consists of the following message:

```
You are accessing a U.S. Government (USG) Information System (IS) that is
provided for USG-authorized use only. By using this IS (which includes any
device attached to this IS), you consent to the following conditions:
-The USG routinely intercepts and monitors communications on this IS for
purposes including, but not limited to, penetration testing, COMSEC
monitoring,
network operations and defense, personnel misconduct (PM), law enforcement
(LE), and counterintelligence (CI) investigations.
-At any time, the USG may inspect and seize data stored on this IS.
-Communications using, or data stored on, this IS are not private, are
subject
to routine monitoring, interception, and search, and may be disclosed or
used
for any USG-authorized purpose.
-This IS includes security measures (e.g., authentication and access
controls)
to protect USG interests--not for your personal benefit or privacy.
-Notwithstanding the above, using this IS does not constitute consent to PM,
LE
or CI investigative searching or monitoring of the content of privileged
communications, or work product, related to personal representation or
services
by attorneys, psychotherapists, or clergy, and their assistants. Such
communications and work product are private and confidential. See User
Agreement for details.
```

You can run different commands regarding the device banner, including changing the message.

1. Using terminal emulation, select the **Advanced Menu > Banner Management** menu option. The following options appear:
 - **Display Banner:** Use to display the current banner information.
 - **Update Banner:** Use to create a new banner message. Enter the message you want to replace the current banner.
 - **Disable/Enable Banner:** Use to disable the banner, or re-enable the banner if it is currently disabled. If the banner is disabled, you are prompted to enter your password when you attempt to log into the device with no banner message appearing.
 - **Reset Banner:** Use to revert the existing banner message to the default one that came with the device.
2. Enter your option choice and continue.

Managing the Network

You can manage various device network capabilities from the Serial Console.

1. Using terminal emulation, select the **Advanced Menu > Network Management** menu option. The following options appear:

- **MACsec Status:** Use to show the current status of the network connection over MACsec. If the status isn't OK, the device attempts to repair the MACsec connection by flapping the interface.
 - **Internet Gateway Status:** Use to show which internet gateways (IGWs) are active and how the connection from on-premises flows for instances on nodes without an IGW.
 - **VNIC Information Table:** Use to show detailed information (IP, DNS Name, Attachment information) about all the VNICs that have been created on the system.
 - **Diagnostic Commands:** Use to run diagnostics commands from the Serial Console to help troubleshoot network connectivity issues. Currently, Roving Edge Infrastructure supports the Ping and Traceroute commands.
2. Enter your option choice and continue.

Managing Your Password

You can manage the number of password attempts allowed in the Serial Console.

1. Using terminal emulation, select the **Advanced Menu > Network Management** menu option. The following option appears:
 - No. of attempts before key is shredded (Default:10)**
2. Select this option. The following option appears:
 - Enter number of unlock attempt allowed (between 3 and 100)**
3. Enter the number of attempts the user can try to unlock the device before they are prevented from any further tries. The number of attempts can be between 3 and 100. If you do not provide a value, the default number 10 is used.

When you attempt to login and provide an incorrect password, a message similar to the following appears:

```
Enter the passphrase to unlock the screen: ****
*** 1 failed attempt out of 4 allowed attempts. Once failed attempt reach 4,
data access will be lost. ***
Error: The passphrase is incorrect!
```

If you reach your final attempt before you exceed the number of attempts allowed, a message similar to the following appears:

```
*** Next failed attempt will shred the unlock key and data access to this
device will be lost. Used 3 attempts out 4 allowed attempts. ***
Error: The passphrase is incorrect!
```

Note:

You can test this feature after specifying the number by waiting for the screen timeout (900 seconds) to occur and the screen becomes locked. Try logging in using an incorrect password and view the result. Make sure you do not exceed your number of tries allowed, or you will lose your passphrase.

Managing Your System Upgrades

You can disable your Roving Edge Infrastructure device's ability to have its system upgraded in a disconnected environment using the Serial Console. Disable the disconnected upgrade by discarding the signing public key. You can also display the device's signing public key.

1. Using terminal emulation, select the **Advanced Menu > System Upgrade Management** menu option. The following options appear:
 - **Disable Disconnected Upgrade:** Use to disable the disconnected upgrade feature by discarding the public signing key. See [Device Software Management](#) for general information.

Note:

This is an irreversible action. You cannot perform a disconnected upgrade until the key is restored by connecting back to Oracle Cloud Infrastructure. Do not perform this operation unless advised by Oracle to discard the upgrade bundle signing public key.

- **Display Signing Public Key:** Use to display the public key corresponding to the private key that was used to sign the disconnected upgrade bundle.
2. Enter you option choice and continue.

Displaying the Serial Encryption Key

There are times when you need to access the encryption key from the Roving Edge Infrastructure device through the Serial Console. For example, if you are encrypting a downloaded diagnosis bundle that you are preparing to forward to Oracle for analysis.

1. Using terminal emulation, select the **Diagnostics** menu option. The **Diagnostics Menu** appears.
2. Select **Show Diagnostics Bundle Encryption Key**. The encryption key is displayed.
3. Record the key for use as needed.

Accessing a Roving Edge Infrastructure Device

Describes the different methods for accessing a Roving Edge Infrastructure device.

The Command Line Interface (CLI) is covered in a separate topic due to the complexity of the configuration. See [Using the Command Line Interface with a Device](#).

Note:

Use only ASCII text for all inputs to Roving Edge Infrastructure and Roving Edge Infrastructure devices. This requirement applies to the browser-based Consoles, CLIs, and APIs.

Accessing the Oracle Cloud Infrastructure Cloud Console

You can create and manage your Roving Edge Infrastructure device-based nodes using the Oracle Cloud Infrastructure Cloud Console. Here is where you also specify the workloads that determine the provision of these devices.

Note:

You must have internet access to access the Oracle Cloud Infrastructure Cloud Console.

Accessing the Roving Edge Infrastructure Device Console

Use the browser-based Roving Edge Infrastructure Device Console to manage your workloads, perform tasks, and monitor system health. No internet access is required to access the Device Console. You can synchronize your object storage data using a connection to your home region.

The Device Console retains the look and feel of the OCI Cloud Console, and allows you to manage and control the on-box services on your device.

When you first sign in to the Device Console, you're prompted to regenerate the password. The Device Console expires after 90 days, after which you must reset it.

Important:

Securely store the Device Console password. If you lose or forget this password, you can't retrieve it and you're no longer able to access the Device Console. Don't share this password with other users who might reset the password and not communicate the change. We recommend you closely manage your Device Console passwords within your organization.

User Management

We recommend creating users and assigning them to user groups. You can then apply permissions to these user groups for better access management. See [Identity and Access Management \(IAM\)](#).

Device Console Sessions

You can have a maximum of three Device Console sessions per user connected to a Roving Edge Infrastructure device at a time. A session is considered a user sign-in into Roving Edge Infrastructure device from a single browser. You can have several tabs open within a specific browser, such as Chrome or Firefox, but it's still considered a single session. However, using two or more different browsers counts as separate sessions toward the maximum.

If you try to access Device Console sessions beyond this maximum limit, you receive an error. If you're at the maximum number of allowed sessions, close an existing session by logging out of the Device Console before opening a new one.

A Device Console session is automatically ended after 15 minutes of inactivity. When active, a session is automatically ended after 4 hours.

API Keys

You can set up API keys and use them to communicate with the RED using the Oracle Cloud Infrastructure command line interface (CLI). See [API Signing Keys](#).

The following example shows how you can use the CLI to set up API keys for managing the password:

```
Get the credential ocid for the user
$ oci iam user oauth2-credential list --user-id

Delete the credential for the user
$ oci iam user oauth2-credential delete --user-id <> --oauth2-client-credential-id <>

Create a new credential (note the generated password from the response to
login to UI, UI will ask for regenerate password on login)
$oci iam user oauth2-credential create --user-id <> --name "UI-console-
oauth-credential" --description "Oauth credential for UI Console" --scopes
'[{ "audience": "", "scope": <tenancy_id> } ]'

Response:
{
  "data": {
    "compartment-id": "ocidl.tenancy.orei..exampleuniqueID",
    "description": "Oauth credential for UI Console",
    "expires-on": "2023-06-15T17:06:52.487000+00:00",
    "id": "ocidl.credential.orei..exampleuniqueID",
    "lifecycle-state": "ACTIVE",
    "name": "UI-console-oauth-credential",
    "password": "T<z0[;EzIK_MPA-Ayew5",
    "scopes": [
      {
        "audience": "",
        "scope": "ocidl.tenancy.orei..exampleuniqueID"
      }
    ]
  }
}
```

```

    ],
    "time-created": "2023-06-15T17:06:52.490000+00:00",
    "user-id": "ocidl.user.orei..exampleuniqueID"
  },
  "etag": "0fcd03d4fdb303335f6b24fda89b2a879a1461d"
}

```

Certificate Requirements

Download a root CA certificate from each Roving Edge Infrastructure device and import it to your Device Console host to gain access to that device. The following sections describe this process for different operating systems.

Linux and Mac OS

Linux and Mac OS: Use the following command to download the root CA certificate from a Roving Edge Infrastructure device:

```
echo -n | openssl s_client -showcerts -connect ip_address:8015 | sed -ne '/-BEGIN CERTIFICATE-/,/-END CERTIFICATE-/p' > redroot.pem
```

where *ip_address* is the IP address of the Roving Edge Infrastructure device.

To access the Device Console with a host name, use one or both the following methods:

First, obtain the SSL certificate device name by using the following command with the `redroot.pem` file downloaded:

```
openssl x509 -in redroot.pem -text -noout | grep DNS
```

- If the output of the above command is prefixed with `*`, it indicates a wildcard certificate. Prefix the value with the subdomain of your choice and add the host name and IP address to the hosts file on your local system.
- If the output has multiple DNS values, use any of the comma-separated values and add the host name and IP address to the hosts file on your local system.

If you are using a Mac OS system on a Safari or Chrome browser, use the MacOS Keychain. Open the Finder and look for the `redroot.pem` file. Double-click the file and install the certificate.

If you are using a Mac OS or Linux system on a Firefox browser, go to **Firefox Settings (or Preferences) > Privacy & Security > View Certificates > Authorities tab > Import** and select the `redroot.pem` file. If a pop-up appears about trust settings, check both boxes regarding ability to identify websites and identify mail users.

If you are using a Linux system on a Chrome browser, go to **Chrome Settings (or Preferences) > Security and Privacy > Security > Manage certificates > Authorities tab > Import > Browse** and choose the `redroot.pem` file in the location where you created it. Next, click **Open** and select the **Trust this certificate for identifying websites** option. The certificate appears in the list of certificate authorities.

Now you can securely access the Device Console with your browser.

Windows

As a prerequisite, download and use the pre-built openssl binaries from the following sites:

- <https://wiki.openssl.org/index.php/Binaries>
- <https://github.com/curl/curl-for-win>
- <https://curl.se/windows/>

Next, obtain the Roving Edge Infrastructure device's Root CA and Intermediate CA using SSL by running the following command:

```
execute command - openssl.exe s_client -connect device_ip_address:8015 -showcerts
```

For example:

```
D:\temp\openssl-3.0.0-win64-mingw\bin>openssl.exe s_client -connect
10.145.140.57:8015 -showcerts
CONNECTED(00000130)
Can't use SSL_get_servername
depth=2 C = US, ST = CA, O = Oracle Corporation, OU = Oracle Roving Edge
  Infra, CN = lab-17-red-1-root-CA
verify error:num=19:self-signed certificate in certificate chain
verify return:1
depth=2 C = US, ST = CA, O = Oracle Corporation, OU = Oracle Roving Edge
  Infra, CN = lab-17-red-1-root-CA
verify return:1
depth=1 C = US, ST = CA, O = Oracle Corporation, OU = Oracle Roving Edge
  Infra, CN = lab-17-red-1-intermediate-CA
verify return:1
depth=0 C = US, ST = CA, O = Oracle Corporation, OU = Oracle Roving Edge
  Infra, CN = lab-17-red-1
verify return:1
```

Obtain the certificate by pointing your browser at the Roving Edge Infrastructure device and clicking the **NET-ERR_CERT_AUTHORITY_INVALID** error message that appears.

The root CA certificate is the last (or third) certificate in the chain shown by Edge and Chrome browsers, or the middle (or second) certificate in Firefox browsers. Copy and paste the root CA certificate from the browser to Notepad and save the file with the filename `redroot.cer`. The certificate starts with a line containing: `BEGIN CERTIFICATE` and end with the line containing: `END CERTIFICATE`

If you are using an Edge and Chrome browser, add the certificate to the trust store by opening the File Explorer and double-clicking the `redroot.cer` file. Install the certificate. Place all certificates in the Trusted Root Certificate Authorities folder.

If you are using a Firefox browser, import the `redroot.cer` file into Firefox. Go to Firefox Settings > Privacy & Security > View Certificates > Authorities tab > Import, and choose the `redroot.cer` file. If a pop-up appears about trust settings, check both boxes regarding ability to identify websites and identify mail users.

Now you can securely access the Device Console with your browser.

Command Line Interface

The Oracle Cloud Infrastructure Command Line Interface (CLI) provides a set of commands for configuring and running Roving Edge Infrastructure tasks. Use the CLI as an alternative to running commands from the Device Console. Sometimes you must use the CLI to complete certain tasks where no Device Console equivalent is available.

Use the CLI to perform Roving Edge Infrastructure service tasks within the Oracle Cloud Infrastructure cloud. These tasks can include requesting nodes, and running tasks directly on device nodes. Install the CLI separately on each device. CLIs installed on devices run locally within your environment and don't require internet access.

See [Using the Command Line Interface](#) for information on how to install, set up, and use CLIs with Roving Edge Infrastructure.

API

Roving Edge Infrastructure provides REST APIs for most of its supported features and functionality. [API Reference and Endpoints](#) provides endpoint details and links to the available API reference documents. For general information about using the API, see [REST APIs](#) in the Oracle Cloud Infrastructure documentation.

Using the Command Line Interface with a Roving Edge Infrastructure Device

Describes how to use the Command Line Interface to access a Roving Edge Infrastructure device.

The Oracle Cloud Infrastructure Command Line Interface (CLI) provides a set of commands for configuring and running Roving Edge Infrastructure tasks. Use the CLI as an alternative to running commands from the Device Console. Sometimes you must use the CLI to complete certain tasks where no Device Console equivalent is available.

Use CLIs to perform Roving Edge Infrastructure service tasks within the Oracle Cloud Infrastructure cloud. These tasks can include requesting nodes, and running tasks directly on device nodes. Install the CLI separately on each device. CLIs installed on devices run locally within your environment and don't require internet access.

Minimum Required CLI Version

The minimum CLI version required for Roving Edge Infrastructure is 2.12.1.

Determining CLI Versions

Access the following URL to see the currently available version of the CLI:

<https://github.com/oracle/oci-cli/blob/master/CHANGELOG.rst>

Enter the following command at the prompt to see the version of the CLI currently installed on your machine:

```
oci --version
```

If you have a version on your machine older than the version currently available, install the latest version.

Note:

Always update to the latest version of the CLI. The CLI is not updated automatically, and you can only access new or updated CLI features by installing the current version.

Updating Your Hosts File

Open your `/etc/hosts` file and add an `ip_address host_name` entry for your RED.

Where `ip_address` is the IP address of the Roving Edge Infrastructure device, and `host_name` is the name of the Roving Edge Infrastructure host on which you are running the CLI.

For example:

```
10.0.1.8 rover.mycompany.com
```

Access the hostname by running the following commands:

- Download the `redroot.pem` certificate:

```
echo -n | openssl s_client -showcerts -connect ip_address:8015 | sed -ne '/-BEGIN CERTIFICATE-/,/-END CERTIFICATE-/p' > redroot.pem
```

- Then display the DNS hostnames:

```
openssl x509 -in redroot.pem -text -noout | grep DNS
```

In the command's return, the following appears:

- `DNS:*.certcommonname.com`: This indicates a wildcard certificate. Prefix the certificate with the subdomain of your choice "ex: rover" and open your `/etc/hosts` file and add a line with the following:

```
10.145.140.5 rover.certcommonname.com
```

- `DNS:rover-install-red-1, DNS:...,:` Choose any of the DNS outputs and add the following line to your `/etc/hosts` file:

```
10.145.140.5 rover-install-red-1
```

Open your `/etc/hosts` file and add a line with the following:

```
10.145.140.5 rover.mycompany.com otec-console-local rover-install-red-1
```

If the required parameter value is listed as a variable, for example `name`, then you must provide a value. Enter the command as it appears in the documentation.

The inclusion of `[OPTIONS]` in the command syntax indicates optional parameters. Access the CLI's online help for a list of optional parameters and their usage.

Installing the CLI

Installation and configuration of the CLIs is described in detail in [Command Line Interface \(CLI\)](#) topic in the Oracle Cloud Infrastructure documentation.

Setting Up the Config File

Before setting up the config file, you need to gather the following information:

- Roving Edge Infrastructure tenancy OCID. Obtain the tenancy OCID using the following command:

```
curl -k https://ip_address:12060/v1/tenants/orei
```

where `ip_address` is the IP address of the Roving Edge Infrastructure device. The tenancy OCID is contained in the return, for example:

```
{
  "id" : "ocid1.tenancy.orei..uniqueID",
  "name" : "orei"
}
```

Alternatively, enter the following URL into your Device Console web browser:

```
https://ip_address:12060/v1/tenants/orei
```

The tenancy OCID is returned in your web browser.

- Roving Edge Infrastructure user Identity and Access Management (IAM) OCID. Obtain the tenancy OCID using the following steps:

1. Access the Device Console for your device node.
2. Open the navigation menu and select **Identity Management > Users**.
The **Users** page appears. All users are listed in tabular form.
3. Click the user whose details you want to get. The user's **Details** page appears.
4. Find the **OCID** line under **User Information** in the **Details** page and copy link and save this information.

Keep the IAM User web page open as you need it to upload the public key in PEM format.

5. Create an `.oci` directory in the home directory on the host where you have OCI CLI installed. For example:

- Linux and Macintosh:

```
cd $HOME
mkdir .oci
cd .oci
```

- Windows PowerShell:

```
mkdir %HOMEDRIVE%%HOMEPATH%\.oci
```

```
cd ~
cd .oci
```

- RSA Key Pair in PEM format: In a Linux or Macintosh terminal, or Windows PowerShell window, switch to the `.oci` directory and run:

```
oci setup keys
```

The command creates the following files in the `.oci` directory:

- `oci_api_key_public.pem`
- `oci_api_key.pem`

Return to Device Console and go to the IAM User Details page. Click **API Keys** on the left side of the window, then click **Add Public Key** and select the `oci_api_key_public.pem` file for upload.

After uploading the key, record the **Fingerprint** value as you will need it later for updating the configuration file.

In the `.oci` directory, create the `config` file and populate it with the following:

```
[DEFAULT]
user=user_ocid_from_RED_console
fingerprint=your_fingerprint_generated_after_uploading_the_public_key
key_file=path_to_home_directory/.oci/oci_api_key.pem
tenancy=tenancy_ocid_from_curl_command_or_web_browser
region=region_name
```

Example:

```
[DEFAULT]
user=ocid1.user.orei..uniqueID
fingerprint=10:00:00:db:dd:c4:de:71:a1:01:10:88:f9:95:1e:23
tenancy=ocid1.tenancy.orei..uniqueID
region=us-ashburn-1
key_file=/Users/username/.oci/oci_api_key.pem
```

If you included a passphrase when creating the PEM key, add a line with:

```
pass_phrase=your_passphrase
```

Note:

Roving Edge Infrastructure OCIDs, such as for `user` and `tenancy`, contain `orei` in the values.

If you already have a `config` file with a `DEFAULT` profile, you can create more entries with a profile with the name of your choice.

Each Roving Edge Infrastructure tenancy (device) needs its own profile. You can use a base name and increment the number for each device. The following example uses the profile name `ROVINGEDGE1` from the base name `ROVINGEDGE`:

The following example uses the profile `ROVINGEDGE1`:

```
[DEFAULT]
user=user_ocid
fingerprint=your_fingerprint
key_file=path_to_home_directory/.oci/oci_api_key.pem
tenancy=tenancy_ocid
region=region_name
[ROVINGEDGE1]
user=user_ocid_from_RED_console_UI
fingerprint=your_fingerprint_generated_after_uploading_the_public_key
key_file=path_to_home_directory/.oci/oci_api_key.pem
```

```

tenancy=tenancy_ocid_from_curl_command_or_web_browser
region=region_name

Example:
[DEFAULT]
user=ocidl.user.ocl..uniqueID
fingerprint=10:00:00:db:dd:c4:de:71:a1:01:10:88:f9:95:1e:23
tenancy=ocidl.tenancy.ocl..uniqueID
region=us-ashburn-1
key_file=/Users/username/.oci/oci_api_key.pem
[ROVINGEDGE1]
user=ocidl.user.orei..uniqueID
fingerprint=10:00:00:db:dd:c4:de:71:a1:01:10:88:f9:95:1e:23
tenancy=ocidl.tenancy.orei..uniqueID
region=us-ashburn-1
key_file=/Users/username/.oci/oci_api_key.pem

```

Note:

All Roving Edge Infrastructure OCIDS contain the string `orei`.

If you're using a non-default profile name, include the `--profile profile_name` option in all CLI commands. For this example, using the `ROVINGEDGE1` profile requires you include `--profile ROVINGEDGE1` in your CLI syntax. The following section "Setting Up the OCI CLI RC File" describes an optional method of eliminating this requirement.

Each Roving Edge Infrastructure device requires its own profile. Pick a base name such as `ROVINGEDGE` and increment the number for each device. For example: `ROVINGEDGE1`.

Setting Up the OCI CLI RC File

Oracle strongly recommends setting up an optional OCI CLI RC file when using Roving Edge Infrastructure devices. Setting up an OCI CLI RC file makes running CLI commands easier by eliminating the need to include the `--profile profile_name` option in all CLI commands.

The OCI CLI RC file needs to match the profile set in the `config` file. If you are using a `DEFAULT` profile in the `config` file, the OCI CLI RC file also uses `DEFAULT`. If you created a profile with another name, such as `ROVINGEDGE1`, use `ROVINGEDGE1` profile for the OCI CLI RC file.

Before setting up the OCI CLI RC file, perform the following tasks to get the following information:

- Create a cert bundle:

Return to where you generated your PEM keys and run the following command:

```

echo -n | openssl s_client -showcerts -connect ip_address:8015|sed -ne '/-
BEGIN CERTIFICATE-/,/-END CERTIFICATE-/p' > bundle.pem

```

A file with three certificates is created in the `.oci` directory. Record the path for future use.

- Create a file called `oci_cli_rc` in the `.oci` directory with the following contents:

```

[DEFAULT]
# Specifies cert bundle to use
cert-bundle = path_to_bundle/.oci/bundle.pem
# Specifies default compartment id so it doesn't have to be set as env
variable or on CLI
compartment-id = tenancy_ocid_used_in_config_file
# Defines endpoint to use for compute
compute.endpoint = https://otec-console-local:19060
# Defines endpoint to use for object storage
os.endpoint = https://otec-console-local:8019
# Defines namespace
os.namespace = rover-namespace

```



```
# Defines endpoint to use for IAM
iam.endpoint = https://otec-console-local:12050
# Defined endpoint for block
bv.endpoint = https://otec-console-local:5012
# Defined endpoint for VCN 18336
network.endpoint = https://otec-console-local:18336
```

If you already have an `oci_cli_rc` file configured with a `DEFAULT` entry, match the name used in the config file. If you use another profile name (for example, `ROVINGEDGE1`), the `oci_cli_rc` file includes that name. For example:

```
[DEFAULT]
# Defines OCI Tenancy object namespace
os.namespace = idbcq3arv1py
[ROVINGEDGE1]
# Specifies cert bundle to use
cert-bundle = /Users/username/.oci/bundle.pem
# Specifies default compartment id so it doesn't have to be set as env
variable or on CLI
compartment-id = ocidl.tenancy.orei..uniqueID
# Defines Roving Edge endpoint to use for compute
compute.endpoint = https://otec-console-local:19060
# Defines Roving Edge endpoint to use for object storage
os.endpoint = https://otec-console-local:8019
# Defines Roving Edge object namespace
os.namespace = rover-namespace
# Defines Roving Edge endpoint to use for IAM
iam.endpoint = https://otec-console-local:12050
# Defined Roving Edge endpoint for block
bv.endpoint = https://otec-console-local:5012
# Defined Roving Edge endpoint for VCN 18336
network.endpoint = https://otec-console-local:18336
```

Using the CLI

You can specify CLI options using the following commands:

- `--option value or`
- `--option=value`

Not using the OCI CLI RC File

If you are not using an `oci_cli_rc` file, the basic CLI syntax for Roving Edge Infrastructure is:

```
oci resource action options --endpoint resource_endpoint --compartment-
id Roving_Edge_tenancy_ocid_used_in_config_file --cert-bundle path_to_cert
bundle
```

This syntax is applied to the following:

- `oci` is the shortened CLI command name
- `os bucket` is an example of a *resource*
- `create` is an example of an *action*
- Other strings are *options*

Resource endpoints are:

- **Object Storage:** `https://otec-console-local:8019`
Object Storage commands also need to include the `--namespace rover-namespace` option.
- **Compute:** `https://otec-console-local:19060`
- **Block Storage:** `https://otec-console-local:5012`

- **IAM:** `https://otec-console-local:12050`
- **Network:** `https://otec-console-local:18336`
- **Data Sync:** `https://otec-console-local:21060`
- **System Upgrade:** `https://otec-console-local:23060`
- **Events:** `https://otec-console-local:18000`
- **Monitoring:** `https://otec-console-local:22060`
- **Diagnostic Tooling:** `https://otec-console-local:31060`

Include the value `otec-console-local` for the IP address line entry in the `/etc/hosts` file to use the `oci_cli_rc` file functionality.

If you are using an Oracle Cloud Infrastructure certificate, resource endpoints are::

Ex: `DNS: *.commonname.com`

- **Object Storage:** `https://rover.commonname.com:8019`
Object Storage commands also need to include the `--namespace rover-namespace` option.
- **Compute:** `https://rover.commonname.com:19060`
- **Block Storage:** `https://rover.commonname.com:5012`
- **IAM:** `https://rover.commonname.com:12050`
- **Network:** `https://rover.commonname.com:18336`
- **Data Sync:** `https://rover.commonname.com:21060`
- **System Upgrade:** `https://rover.commonname.com:23060`
- **Events:** `https://rover.commonname.com:18000`
- **Monitoring:** `https://rover.commonname.com:22060`
- **Diagnostic Tooling:** `https://rover.commonname.com:31060`

Note:

If the device certificate is self-signed, include the value `otec-console-local` for the IP address line entry in the `/etc/hosts` file to use the `oci_cli_rc` file functionality.

This is an example of a CLI command:

```
oci os bucket list --compartment-id ocidl.tenancy.orei..uniqueID --endpoint
https://otec-console-local:8019 --cert-bundle /Users/username/.oci/
bundle.pem
```

If your `config` file entry for the Roving Edge Infrastructure environment is not `DEFAULT`, include the `--profile profile_name` option in your CLI syntax. For example:

```
oci os bucket list --compartment-id ocidl.tenancy.orei..uniqueID --endpoint
https://otec-console-local:8019 --cert-bundle /Users/username/.oci/
bundle.pem --profile ROVINGEDGE1
```

Note:

Avoid entering confidential information as part of the display name.

Using the OCI CLI RC File

If you are using the `oci_cli_rc` file, the basic CLI syntax for Roving Edge Infrastructure is:

```
oci resource action options
```

This syntax is applied to the following:

- `oci` is the shortened CLI command name

- `os bucket` is an example of a *resource*
- `list` is an example of an *action*
- Other strings are *options*

The following command line example shows a typical CLI command construct for listing the buckets in a specified compartment:

```
oci os bucket list --compartment-id ocidl.tenancy.orei..uniqueID
```

If your config file entry for the Roving Edge Infrastructure environment is not `DEFAULT`, you must also include the `--profile profile_name` option in your CLI syntax. For example:

```
oci os bucket list --compartment-id ocidl.tenancy.orei..uniqueID --endpoint
https://otec-console-local:8019 --cert-bundle /Users/username/.oci/
bundle.pem --profile ROVINGEDGE1
```

Required and Optional Parameters

Most command line utilities have both required and optional parameters that are included with the command. Required parameters are included in the command's syntax, for example:

```
oci os bucket create --name name [OPTIONS]
```

If the required parameter value is listed as a variable, for example *name*, then you must provide a value. Enter the command as it appears in the documentation.

The inclusion of `[OPTIONS]` in the command syntax indicates optional parameters. Access the CLI's online help for a list of optional parameters and their usage.

Running CLIs on a VM Instance

Follow these guidelines for running CLIs on compute instances hosted by Roving Edge Infrastructure devices.

Note:

The instructions in this topic are for Oracle Linux host computers.

- Have the VM go through the following local IP:
169.254.169.254
- Have the VM refer to the Roving Edge Infrastructure device as `otec-console-local`.
- Employ the following IP Tables rules:

```
{ for i in 19060 8019 12050 21060 22060 23060 22060 12060;do iptables -I
BareMetalInstanceServices -d 169.254.169.254/32 -p tcp -m tcp --dport $i -
m
comment --comment "Rover service access port" -j ACCEPT;done }
```

See [Service Ports](#) for a list of available ports.

Unsupported CLI Commands

The following CLI commands are currently not supported. Workarounds are provided where available.

- **Object Storage CLIs:** `oci os list`

You can only use the `oci os list` command when you include the `--fields` option. For example:

```
# oci os object list --bucket-name generic-image --fields
name,size,timeCreated,md5,etag
{
```

```

"data": [
  {
    "archival-state": null,
    "etag": "b2c123ff0f1231c4c7f41ff92294e4a0-32",
    "md5": "ssYx/w8SUcTH9B/5IpTkoA==--32",
    "name": "exported-image",
    "size": 2132357120,
    "storage-tier": null,
    "time-created": "2022-03-01T19:50:03.076000+00:00",
    "time-modified": null
  },
  {
    "archival-state": null,
    "etag": "fe5e3c12e12e31de65b86722a6fe29e7-32",
    "md5": "/l48A0leMd5luGcipv4p5w==--32",
    "name": "imported-
image-20210830-1542_ocid1.image.oc1.iad..uniqueID.oci",
    "size": 2132224000,
    "storage-tier": null,
    "time-created": "2022-03-01T19:50:59.968000+00:00",
    "time-modified": null
  }
],
"prefixes": []
}

```

- **Compute CLIs:** `oci compute instance list-vnics`

The `oci compute instance list-vnics` command lists the VNICs that are attached to the specified instance and is often used to get the public IP for a compute node. This CLI is not currently supported in Roving Edge Infrastructure. You can get VNIC information, including IP address associated with a VNIC attached to a compute node, using any of the following methods:

- **Device Console:** Go to the following location:

Compute > Instances > Instance Details > Attached VNICs

The IP addresses for the VNICs are listed in the dialog box that appears.

- **CLI:** `oci compute instance list-vnics`

First, run the following command to list all the VNIC's attachments:

```
oci compute vnic-attachment list --instance-id <> --all
```

Next, run the following command for the specific VNIC for which you want to get details:

```
oci network vnic get --vnic-id <>
```

The following example shows these two commands run together with their respective returns:

```

# oci compute vnic-attachment list --instance-id
ocid1.instance.orei.orei-1..uniqueID --all
{
  "data": [
    {
      "availability-domain": "orei-1-ad-1",
      "compartment-id": "ocid1.tenancy.orei..uniqueID",
      "display-name": null,
      "id": "ocid1.vnicattachment.orei.orei-1..uniqueID",
      "instance-id": "ocid1.instance.orei.orei-1..uniqueID",
      "lifecycle-state": "ATTACHED",
      "nic-index": 0,
      "subnet-id": "ocid1.subnet.orei.orei-1..uniqueID",
      "time-created": "2022-03-01T21:07:00.937000+00:00",
      "vlan-id": null,

```

```

        "vlan-tag": 1,
        "vnic-id": "ocidl.vnic.orei.orei-1..uniqueID"
    }
]
}

# oci network vnic get --vnic-id ocidl.vnic.orei.orei-1..uniqueID
{
  "data": {
    "availability-domain": "orei-1-ad-1",
    "compartment-id": "ocidl.tenancy.orei..uniqueID",
    "defined-tags": {},
    "display-name": "test-instance",
    "freeform-tags": {},
    "hostname-label": "test-instance",
    "id": "ocidl.vnic.orei.orei-1..uniqueID",
    "is-primary": true,
    "lifecycle-state": "AVAILABLE",
    "mac-address": "02:00:17:00:04:00",
    "nsg-ids": [],
    "private-ip": "10.0.0.2",
    "public-ip": "10.145.142.128",
    "skip-source-dest-check": false,
    "subnet-id": "ocidl.subnet.orei.orei-1..",
    "time-created": "2022-03-01T21:07:00.155000+00:00",
    "vlan-id": null
  },
  "etag": "2c082d1c"
}

```

If only one VNIC is attached, you can combine these CLI commands with other Linux tools to limit the output to just the public IP address using the following command:

```

oci compute vnic-attachment list --instance-id <> --all|grep -m 1 vnic-
id|awk -F'"' '{print $4}'|xargs -I{} oci network vnic get --vnic-id {}|
grep public-ip|awk -F'"' '{print $4}'

```

For example:

```

# oci compute vnic-attachment list --instance-id
ocidl.instance.orei.orei-1..uniqueID --all|grep -m 1 vnic-id|awk -F'"'
'{print $4}'|xargs -I{} oci network vnic get --vnic-id {}|grep public-
ip|awk -F'"' '{print $4}'
10.145.142.128

```

Accessing Command Line Interface Help

All CLI help commands have an associated help component you can access from the command line. To view the help, enter any command followed by the `--help` or `-h` option. For example:

```

oci os bucket --help

```

Ruggedizing Roving Edge Infrastructure Devices

Describes how to install the ruggedizing protections to your Roving Edge Infrastructure device.

Each Oracle Roving Edge Device comes assembled in the ruggedized case. Follow the instructions in this section to use your Roving Edge Device within its ruggedized case. Removing the device from the case is not recommended and might damage the device.

1. Remove the endcaps from the Ruggedized Transit Case by locating the wing-turn latches on both sides and turning these counter clockwise as shown to unlatch each endcap.

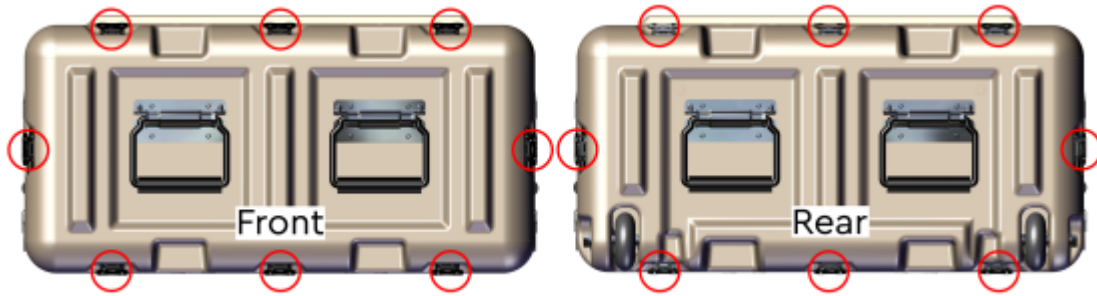

Figure 1: Wing-Turn Latch Location

The wing-turn latches can be found in the locations shown. There are a total of eight wing-turn latches on each cap.

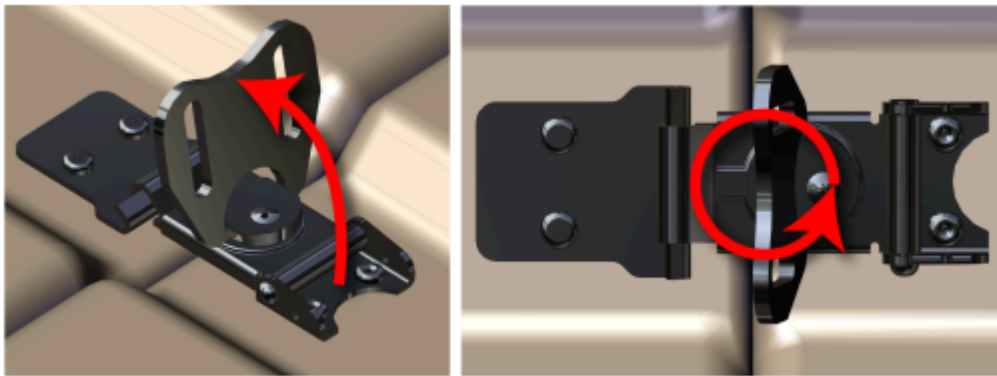

Figure 2: Wing-Turn Latch Operation

Pull the endcaps away from the case.

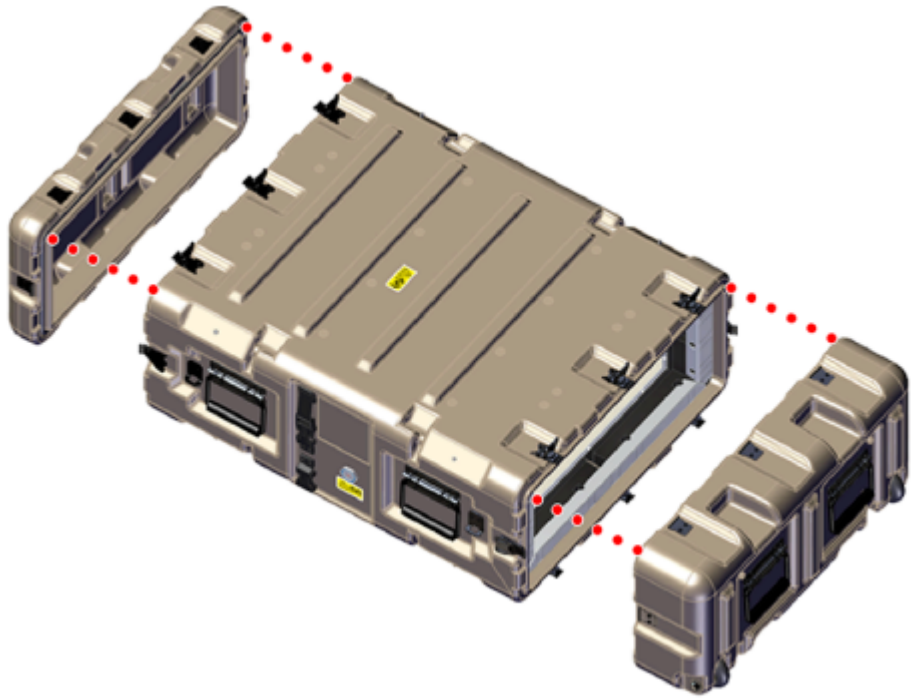

Figure 3: Removing the Endcaps from the Ruggedized Transit Case

- 2. Prepare the EMI Filter assemblies for system installation.

Note:
The EMI Filter assemblies will remain attached to the Faraday Cage with ground cables during the installation of the system. These ground cables are delicate and may be damaged if the EMI Filter assembly is pulled too hard.

- a. From the front of the Ruggedized Transit Case, use a T15 Torx.

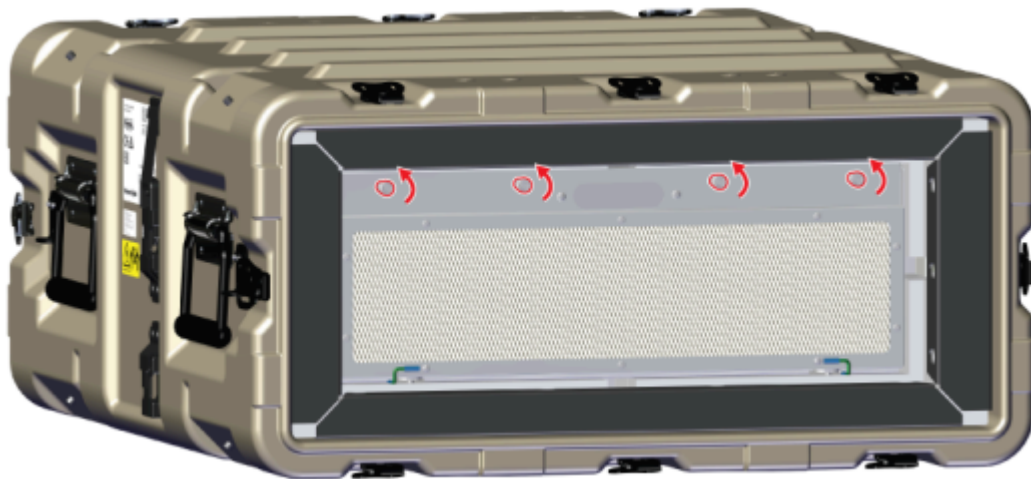

Figure 4: Loosen the Front EMI Filter Assembly Captive Screws

- b. Carefully rotate the top of the EMI filter assembly down until it is resting on the case as shown in the following image.

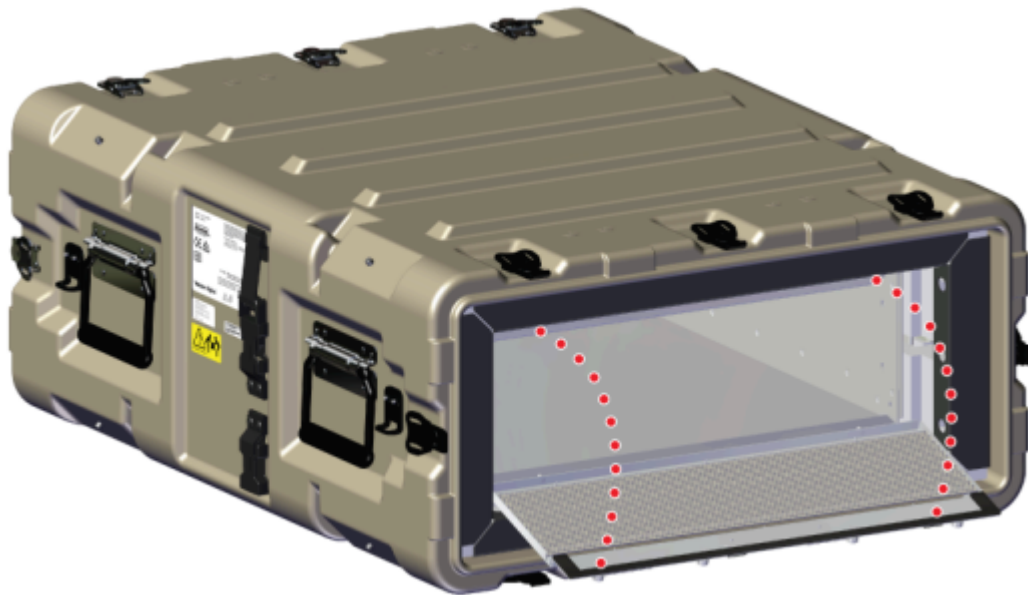

Figure 5: Rotating the Front EMI Filter Assembly

- c. From the rear of the Ruggedized Transit Case, use a T15 Torx screwdriver to loosen the captive screws on the rear EMI Filter assembly.



Figure 6: Loosen the Rear EMI Filter Assembly Captive Screws

- d. Carefully rotate the top of the EMI filter assembly down until it is resting on the case as shown in the following image. Be careful not to damage the ground wires attached to the bottom of the EMI filter assembly.

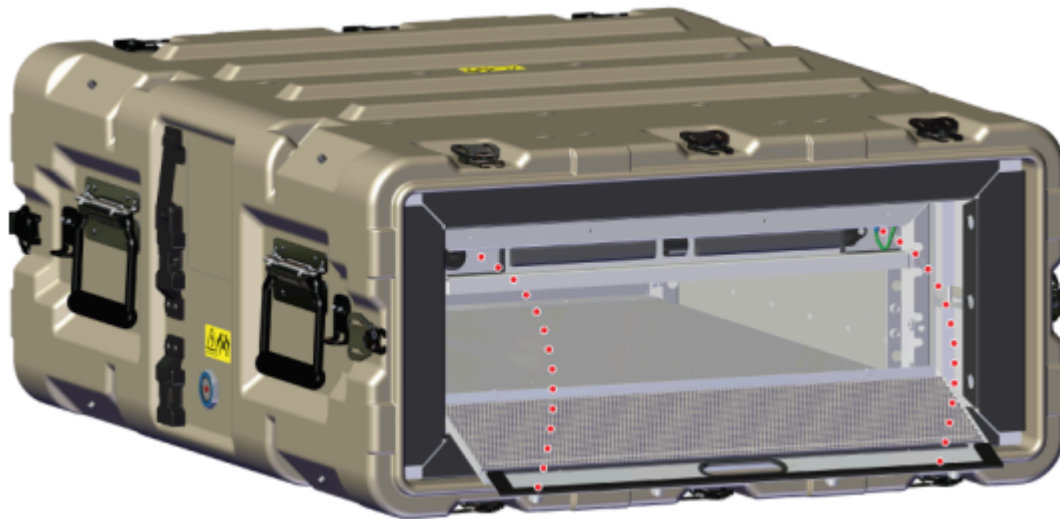

Figure 7: Rotating the Rear EMI Filter Assembly

3. Connect the internal power cable from the Faraday cage to the rear of the system as shown:

Note:

If the system and Ruggedized Transit Case configuration will be transported to another site, do not install the cables.

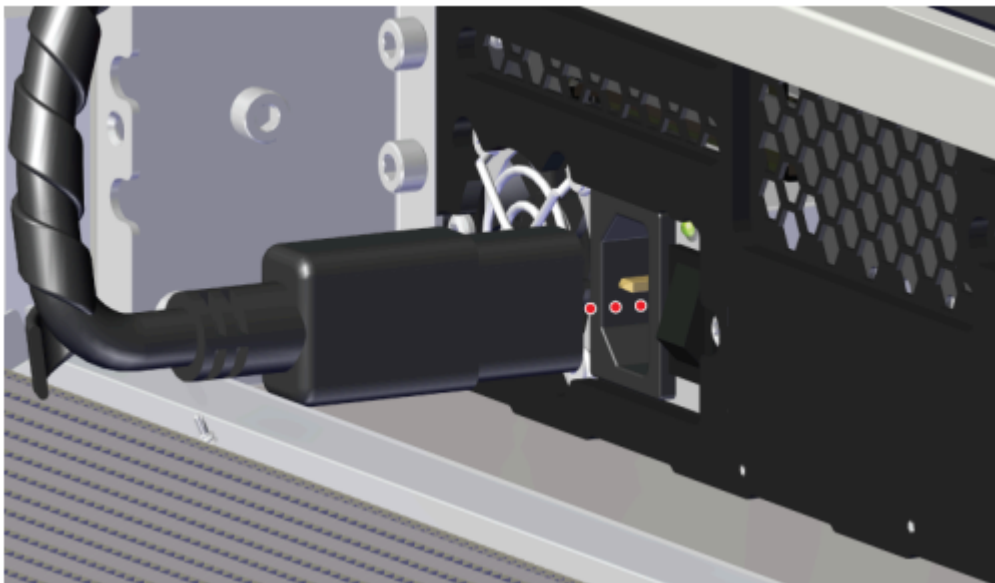

Figure 8: Connecting the Faraday Cage Power Cable

4. Install the data and power cables and re-seat the EMI Filter assembly onto the Faraday Cage.
 - a. Route the QSFP28, DB9, and Ethernet (optional) cables through the left cable channel and pull to ensure there is enough slack to connect the cables into each of their ports.

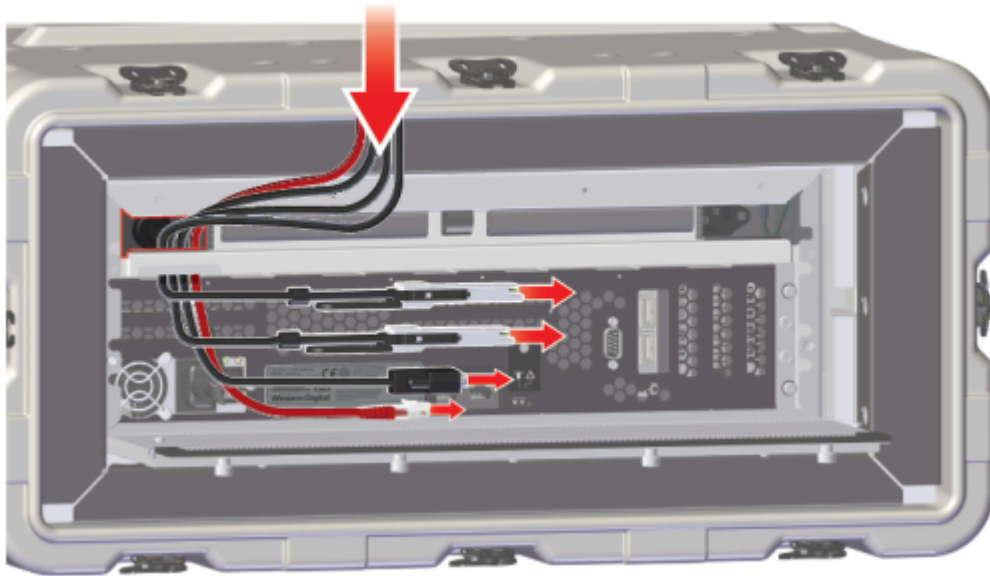

Figure 9: Data Cable Left Channel Route

- b. Connect each cable into the designated ports, route cable slack through the foam channels, and route the other end of the data cables through the oval cutout on the EMI Filter assembly.

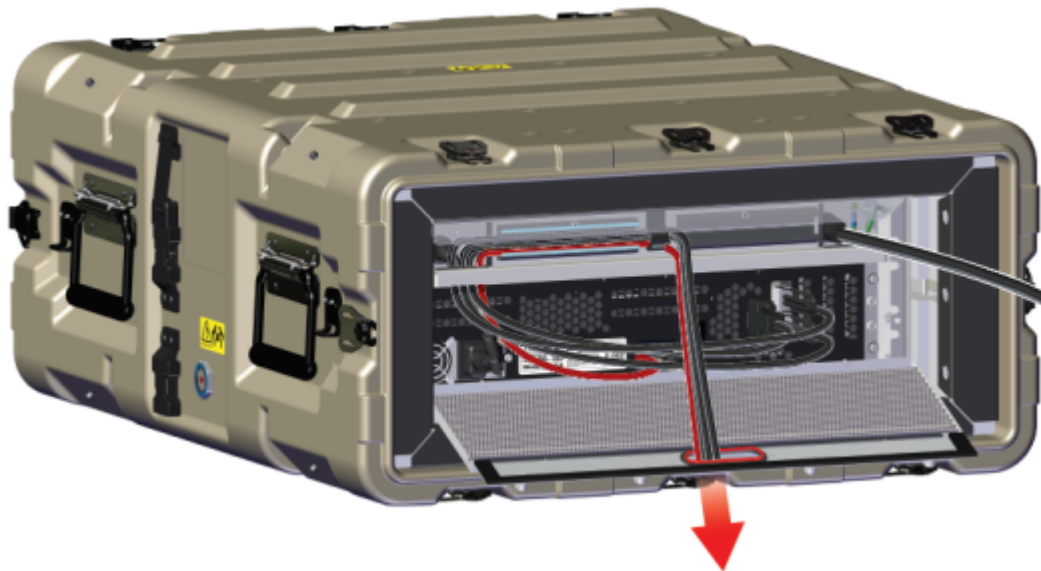

Figure 10: Data Cable Left Channel Route

- c. Connect the power cable into the port located in right cable channel, route cable slack through the foam channel and cable mount, and through the oval cutout on the EMI Filter assembly as shown.

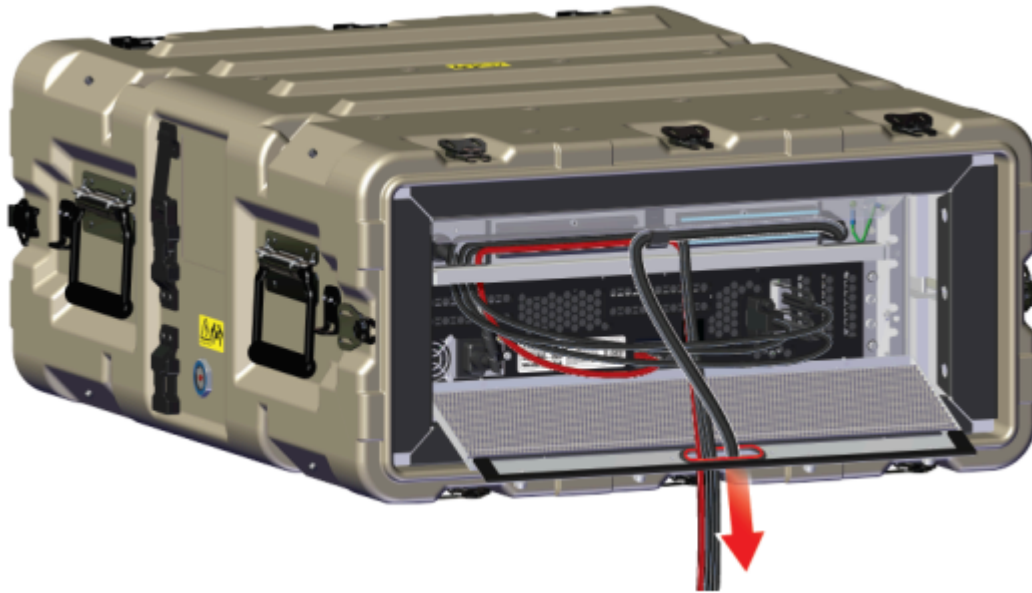

Figure 11: Power Cable Connection and Routing

- d. With the cables secured in place rotate and push the EMI Filter assembly forward to align the captive screws with the screw holes and begin tightening them with thumb and finger. Be sure to apply pressure as the foam channels that route cables will provide resistance. Once the cables and EMI filter are properly in place, use a T15 Torx screwdriver to tighten the captive screws on the front EMI Filter assembly.

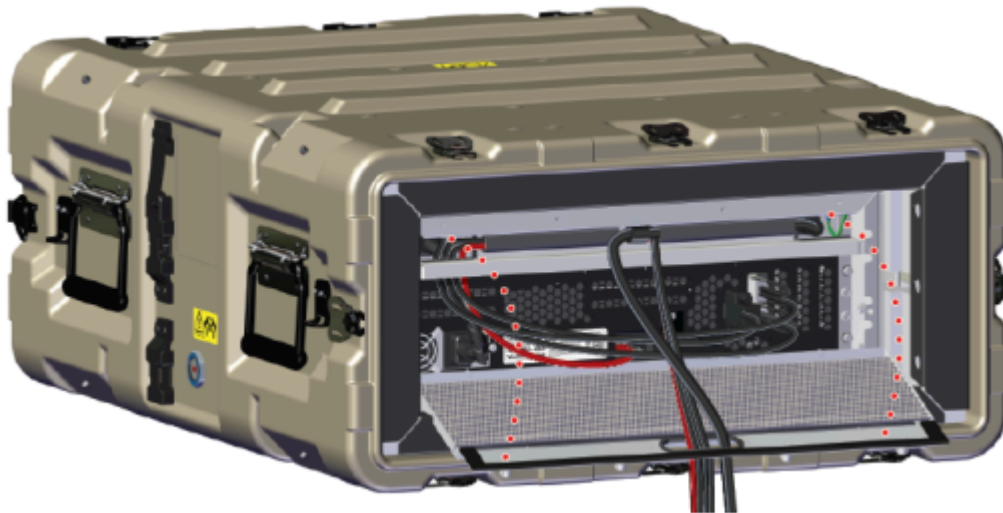

Figure 12: Rotating and Seating the Rear EMI Filter Assembly

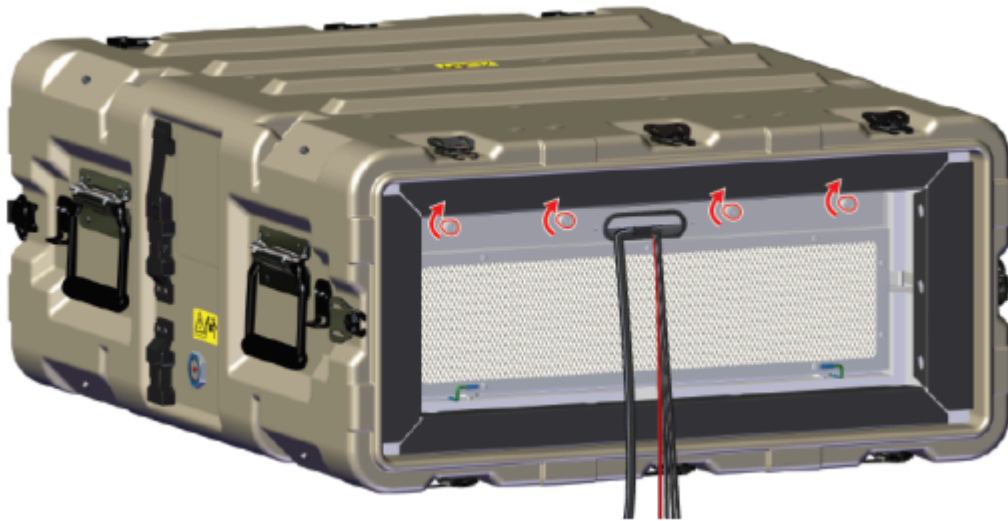

Figure 13: Tighten the Rear EMI Filter Assembly Captive Screws

5. Identify the EMI Filter assembly for the front end of the Faraday cage. The front EMI Filter assembly will be a full screen, whereas the rear EMI Filter will have an oval cutout for routing cabling to the rear of the enclosure.
 - a. From the front of the Ruggedized Transit Case, carefully rotate the top of the EMI filter assembly up until it is aligned with the EMI filter assembly screw holes on the Faraday Cage as shown in the following image. Be careful not to damage the ground wires attached to the bottom of the EMI filter assembly.



Figure 14: Rotating and Seating the Front EMI Filter Assembly

- b. Use a T15 Torx screwdriver to tighten the captive screws on the front EMI Filter assembly.

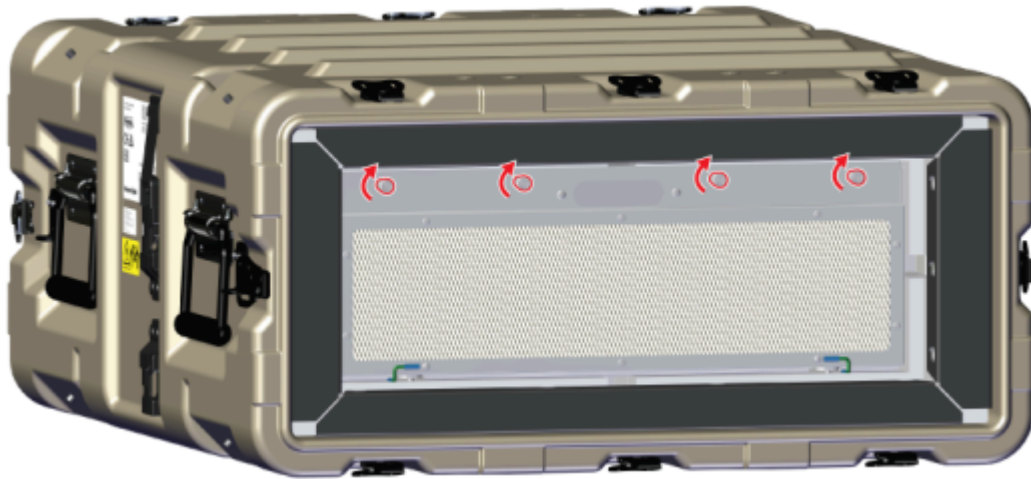

Figure 15: Securing the Front EMI Filter Assembly

- c. Be aware and ensure that the ground cables on the EMI Filter assembly do not get pinched during re-installation.

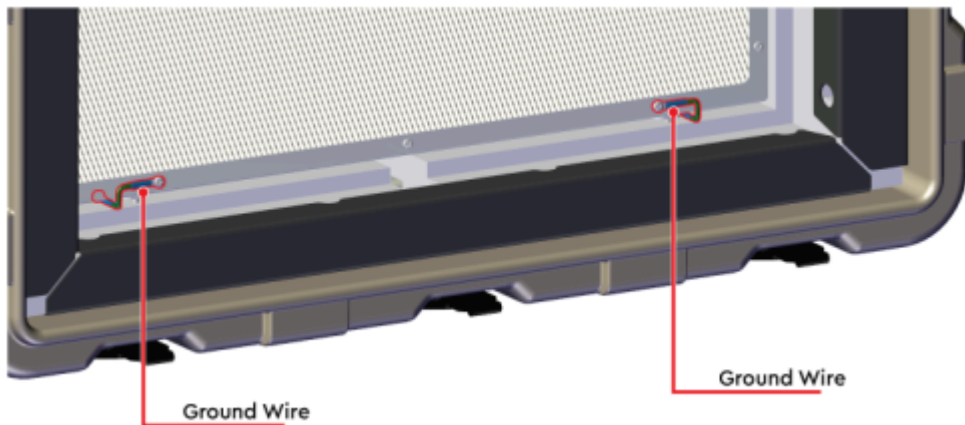

Figure 16: Ground Wire Identification

Roving Edge Infrastructure Device Compartments

Describes how the Roving Edge Infrastructure device uses its compartment, and how to gain information on it.

Each Roving Edge Infrastructure device contains a single compartment. This compartment also functions as your tenancy when you are working with the device. The single compartment is fixed. You cannot add or remove compartments.

When you use the command line utilities with your device, you often must specify the compartment OCID as a parameter of the command. You can determine the OCID of your device's compartment by following either of these procedures:

- Open a command window on your Roving Edge Infrastructure device and enter the following:

```
curl -k https://ip_address:12060/v1/tenants/orei
{
  "id" : "ocid1.tenancy.orei..exampleuniqueID",
  "name" : "orei"
}
```

The compartment OCID is the value of the "id" in the return.

- Open a browser connected to the Roving Edge Infrastructure device and enter the following URL:
`https://ip_address:12060/v1/tenants/orei`
The browser displays the OCID.

Roving Edge Infrastructure Device Usage Guidelines

Describes guidelines for how much storage and CPU capacity we recommend you use for your Roving Edge Infrastructure devices.

Follow the usage guidelines for Roving Edge Infrastructure devices described in this topic. Exceeding these guidelines can result in performance issues and degradation.

Storage Capacity Usage

We recommend you avoid using more than 80% of your Roving Edge Infrastructure device storage capacity.

For storage capacity details, see [Roving Edge Infrastructure Device Specifications](#) on page 10.

Monitor capacity usage in the Device Console. See [Roving Edge Infrastructure Device Monitoring](#) on page 148.

Storage usage is also displayed in the node details in OCI when you attach your workloads. As more workloads are attached, the amount of available space is recalculated.

Note:

Limit the workload size (sum of all object and image workloads) to 50% or less of the usable capacity of your Roving Edge Infrastructure devices. If your workloads exceed this amount, you receive a warning.

CPU Usage Recommendations

Don't exceed 80% CPU utilization on your Roving Edge Infrastructure devices.

Policies for Managing Roving Edge Infrastructure

Describes how to set up policies to create Roving Edge Infrastructure device orders in Oracle Cloud Infrastructure and also for enabling the provisioning and operation of your Roving Edge Infrastructure devices.

Note:

Before ordering your nodes, you must set up your policies in Oracle Cloud Infrastructure to allow the required user access to various features and functionality associated with Roving Edge Infrastructure.

Allowing Access to Roving Edge Infrastructure Resources in OCI

Use the following syntax to allow your user groups access to Roving Edge Infrastructure resources in your tenancy:

```
allow group <admin_user_group> to manage rover-family in tenancy
```

```
allow group <admin_user_group> to manage rover-nodes in tenancy
```

where <admin_user_group> is a group created to manage Roving Edge Infrastructure administrators.

You can also narrow this access to compartments. For example, if you wanted to allow a group of users to manage all Roving Edge Infrastructure resources in the compartment "finance" in Oracle Cloud Infrastructure, use the following:

```
allow group rover-admins to manage rover-family in compartment finance
```

```
allow group rover-admins to manage rover-nodes in compartment finance
```

Allowing the Roving Edge Infrastructure Service to Attach Workloads

Setting this policy is required to grant the Roving Edge Infrastructure service read access to the buckets being attached as workloads in your node request. This read access policy allows the generation of a manifest file containing the information about the objects you want synced to your Roving Edge Infrastructure devices.

```
allow service rover to read object-family in tenancy
allow service rover to manage objectstorage-namespaces in tenancy
```

Note:

You can narrow your access to a compartment. Ensure you give read access to all the compartments associated with all your workload buckets. For example, if you had two bucket workloads, one in compartment "finance" and the other in compartment "accounts," you would set this policy for both the compartments.

Ordering Roving Edge Infrastructure Devices Using the Console

You can create policy to allow you to order and manage your Roving Edge Infrastructure device using the Create Policy template in the OCI Console.

1. Open the navigation menu and click **Identity & Security**. Under **Identity**, click **Policies**.
2. Click **Create Policy**. The **Create Policy** dialog box appears.
3. Complete the required fields as described in [Creating a Policy](#).
4. Use the **Policy Builder** and select **Let Users Create and Manage Roving Edge Devices** under **Common Policy templates**.
5. Follow the instructions displayed in the **Policy Builder** to configure your policy groups.
6. Click **Create**. Your changes go into effect typically within 10 seconds.

Allowing Your Roving Edge Infrastructure Devices Object Storage Access

This section describes the steps required to allow your Roving Edge Infrastructure device to be provisioned with your Object Storage workloads and to perform data synchronization while the device is in your possession.

Each Roving Edge Infrastructure device node functions as a resource in Oracle Cloud Infrastructure, requiring permission to read/write buckets in your compartments within your tenancy for data sync tasks. After a node is submitted for provisioning, create a dynamic group containing the single node. See [Managing Dynamic Groups](#) for more information on how to create dynamic groups.

Create a dynamic-group called "roving-edge-devices" with the matching rules below:

```
All {resource.type='rovernode' }
```

Grant this dynamic-group a policy to read and write to buckets, for example:

```
allow dynamic-group roving-edge-devices to manage object-family in tenancy
```

Grant dynamic group access to the Object Storage namespace

```
allow dynamic-group roving-edge-devices to manage objectstorage-namespaces
in tenancy
```

Enabling Disconnected Upgrade Bundle Delivery

To enable disconnected upgrade bundles to be delivered to your tenancy, follow these instructions:

Grant the requester object create and overwrite permissions to the destination bucket:

```
allow group <group_name> to manage object-family in compartment
<compartment_name>
```

Grant the object storage service in the region to manage the buckets in your tenancy:

```
allow service objectstorage-<region_identifier> to manage object-family in
tenancy
```

You could also create narrower permissions using:

```
allow service objectstorage-<region_identifier> to manage object-family in
compartment <compartment-name>
where any {request.permission='OBJECT_READ',
request.permission='OBJECT_INSPECT', request.permission='OBJECT_CREATE',
request.permission='OBJECT_OVERWRITE', request.permission='OBJECT_DELETE' }
```

See [Regions and Availability Domains](#) for a list of region identifiers.

Enabling Certificate Management

This section describes the steps required to allow your administrators to create certificate authorities and allow your Roving Edge Infrastructure device to access certificate management resources in the Oracle Cloud Infrastructure Cloud.

Create a policy for the security administrators to create vault and master key:

```
Allow group <security-admin-group> to manage vaults in tenancy
Allow group <security-admin-group> to manage keys in tenancy
```

Create a policy for the security administrators to use the certificate authority:

```
Allow group <security-admin-group> to use certificate-authority-family in
tenancy
Allow group <security-admin-group> to use key-delegate in tenancy
```

Create a dynamic group which could be called `certificate-authority-dynamic-group` with the matching rules:

```
all {resource.type='certificateauthority' }
```

Create a policy for the certificate authority to use keys:

```
Allow dynamic-group certificate-authority-dynamic-group to use keys in
compartment <compartment_name>
```

Create a policy for Roving Edge Infrastructure nodes to fetch and update its certificate configurations:

```
Allow dynamic-group roving-edge-devices to use rover-family in tenancy
```

Create a policy for Roving Edge Infrastructure devices to use the certificate authority and manage certificates:

```
allow dynamic-group roving-edge-devices to manage leaf-certificate-family in
tenancy
allow dynamic-group roving-edge-devices to use certificate-authority-family
in tenancy
```

Policy Examples

The group `rover-admins` is defined to be the administrator for Roving Edge Infrastructure resources:

```
allow group rover-admins to manage rover-family in tenancy
allow group rover-admins to manage rover-nodes in tenancy
```

Allow Roving Edge Infrastructure to attach workloads:

```
allow group rover-admins to read object-family in tenancy
allow group rover-admins to read instance-images in tenancy
```

Allow Roving Edge Infrastructure access to Object Storage:

```
allow dynamic-group roving-edge-devices to manage object-family in tenancy
allow dynamic-group roving-edge-devices to manage objectstorage-namespaces
in tenancy
```

Enable disconnected upgrade bundle delivery:

```
allow group rover-admins to read object-family in tenancy
allow dynamic-group roving-edge-devices to manage object-family in tenancy
```

Enable certificate management:

```
allow group CertificateAdmins to manage vaults in tenancy
allow group CertificateAdmins to manage keys in tenancy
allow group CertificateAdmins to manage certificate-authority-family in
tenancy
allow group CertificateAdmins to use key-delegate in tenancy
allow group rover-admins to read certificate-authority-family in tenancy
allow dynamic-group certificate-authority-dynamic-group to use keys in
tenancy
allow dynamic-group roving-edge-devices to use rover-family in tenancy
allow dynamic-group roving-edge-devices to manage leaf-certificate-family in
tenancy
allow dynamic-group roving-edge-devices to use certificate-authority-family
in tenancy
```

Permissions for Roving Edge Infrastructure

Describes how to set up policies to create Roving Edge Infrastructure device orders in Oracle Cloud Infrastructure and also for enabling the provisioning and operation of your Roving Edge Infrastructure devices.

This topic describes the details for writing user Identity and Access Management (IAM) policies that control access to rules for the services and features supported by your a Roving Edge Infrastructure device. It covers the following topics:

- [Block Volume](#)
- [Certificates](#)
- [Compute](#)

- [Data Synchronization](#)
- [Diagnostics](#)
- [Events](#)
- [Identity and Access Management \(IAM\)](#)
- [Monitoring](#)
- [Networking](#)
- [Object Storage](#)
- [System Upgrades](#)

For more information on IAM policy reference topics, including verbs, resources types, and general variables, see [Policy Reference](#) in the OCI Cloud documentation.

Block Volume Permissions for Roving Edge Infrastructure

Describes the details for writing user IAM policies that control access to rules for the Block Volume service for a Roving Edge Infrastructure device.

Resource-Types

backup-policies

volumes

volume-backups

volume-groups

backup-policy-assignments

volume-group-backups

boot-volume-backups

volume-attachments

boot-volumes

volume-family

Details for Verb + Resource-Type Combinations

The following tables show the permissions and API operations covered by each verb. The level of access is cumulative as you go from inspect > read > use > manage.

backup-policies

Verbs	Permissions	APIs Fully Covered	APIs Partially Covered
inspect	BACKUP_POLICIES_INSPECT	ListVolumeBackupPolicies GetVolumeBackupPolicy	CreateVolumeBackupPolicyAssignment (also need manage backup-policy-assignments)
read	BACKUP_POLICIES_INSPECT	ListVolumeBackupPolicies GetVolumeBackupPolicy	None
use	BACKUP_POLICIES_INSPECT	ListVolumeBackupPolicies GetVolumeBackupPolicy	None

Verbs	Permissions	APIs Fully Covered	APIs Partially Covered
manage	BACKUP_POLICIES_CREATE	ListVolumeBackupPolicies	None
	BACKUP_POLICIES_DELETE	GetVolumeBackupPolicy	
	BACKUP_POLICIES_INSPECT	CreateVolumeBackupPolicy	
	BACKUP_POLICIES_UPDATE	DeleteVolumeBackupPolicy	
		UpdateVolumeBackupPolicy	

volumes

Verbs	Permissions	APIs Fully Covered	APIs Partially Covered
inspect	VOLUME_INSPECT	GetVolume	ListVolumeBackups (also need inspect volume-backups)
		ListVolumes	
		GetVolumeGroup	GetVolumeBackup (also need inspect volume-backups)
		ListVolumeGroups	UpdateVolumeBackup (also need use volume-backups)
		GetBootVolume	DeleteVolumeBackup (also need delete volume-backups)
		GetVolumeHealth	GetBootVolumeBackup (also need inspect volume-backups)
		ListVolumesHealth	UpdateBootVolumeBackup (also need use volume-backups)
		GetVolumeKmsKey	ListBootVolumeBackups (also need inspect boot volume-backups)
		GetBootVolumeKmsKey	DeleteBootVolumeBackup (also need manage volume-backups)
			GetVolumeGroupBackup (also need inspect volume-backups)
			ListVolumeGroupBackups (also need inspect volume-backups)
			UpdateVolumeGroupBackup (also need use volume-backups)
			DeleteVolumeGroupBackup (also need manage volume-backups)
			GetVolumeBackupPolicyAssetAssignment (also need inspect backup-policy-assignments)

Verbs	Permissions	APIs Fully Covered	APIs Partially Covered
read	VOLUME_INSPECT	GetVolume ListVolumes GetVolumeGroup ListVolumeGroups GetBootVolume GetVolumeHealth ListVolumesHealth GetVolumeKmsKey GetBootVolumeKmsKey	None
use	VOLUME_INSPECT VOLUME_UPDATE VOLUME_WRITE	GetVolume ListVolumes GetVolumeGroup ListVolumeGroups GetBootVolume GetVolumeHealth ListVolumesHealth GetVolumeKmsKey GetBootVolumeKmsKey UpdateVolume UpdateVolumeGroup UpdateBootVolume UpdateVolumeKmsKey DeleteVolumeKmsKey UpdateBootVolumeKmsKey DeleteBootVolumeKmsKey ValidateVolumeCreate	CreateVolumeBackup (also need manage volumes and manage volume-backups) CreateBootVolumeBackup (also need manage volumes and manage volume-backups) CreateVolumeGroupBackup (also need manage volumes and manage volume-backups) ValidateVolumeAttachability (also need manage volumes and manage volume-attachments) GetVolumeAttachability (also need manage volumes and manage volume-attachments) CreateVolume (also need read volume-backups and manage volumes) CreateVolumeGroup (also need manage volumes and read volume-backups) CreateBootVolume (also need manage volumes and read boot-volume-backups)

Verbs	Permissions	APIs Fully Covered	APIs Partially Covered
manage	VOLUME_CREATE	GetVolume	CreateVolumeBackup (also need manage volumes and manage volume-backups)
	VOLUME_DELETE	ListVolumes	
	VOLUME_INSPECT	GetVolumeGroup	CreateBootVolumeBackup (also need manage volumes and manage volume-backups)
	VOLUME_MOVE	ListVolumeGroups	
	VOLUME_QUERY	GetBootVolume	CreateVolumeGroupBackup (also need manage volumes and manage volume-backups)
	VOLUME_UPDATE	GetVolumeHealth	
	VOLUME_WRITE	ListVolumesHealth	ValidateVolumeAttachability (also need manage volumes and manage volume-attachments)
		GetVolumeKmsKey	
		GetBootVolumeKmsKey	
		UpdateVolume	GetVolumeAttachability (also need manage volumes and manage volume-attachments)
		UpdateVolumeGroup	
		UpdateBootVolume	CreateVolume (also need read volume-backups and manage volumes)
		UpdateVolumeKmsKey	
		DeleteVolumeKmsKey	CreateVolumeGroup (also need manage volumes and read volume-backups)
		UpdateBootVolumeKmsKey	CreateBootVolume (also need manage volumes and read boot-volume-backups)
		DeleteBootVolumeKmsKey	
		ValidateVolumeCreate	ListVolumeBackups (also need inspect volumes and volume-backups)
		DeleteVolume	
		BatchDeleteVolumes	GetVolumeBackup (also need inspect volumes and volume-backups)
		DeleteVolumeGroup	UpdateVolumeBackup (also need inspect volumes and use volume-backups)
	DeleteBootVolume		
	ChangeVolumeCompartment	DeleteVolumeBackup (also need inspect volumes and manage volume-backups)	
	ChangeBootVolumeCompartment	GetBootVolumeBackup (also need inspect volumes and volume-backups)	
		UpdateBootVolumeBackup (also need inspect volumes and use volume-backups)	
		ListBootVolumeBackups (also need inspect volumes and boot-volume-backups)	
		DeleteBootVolumeBackup (also need inspect volumes and manage volume-backups)	
		GetVolumeGroupBackup (also need inspect volumes and volume-backups)	
		ListVolumeGroupBackups (also need inspect volumes and volume-backups)	
		UpdateVolumeGroupBackup (also need inspect volumes and manage volume-backups)	
		DeleteVolumeGroupBackup (also need inspect volumes and manage volume-backups)	
		GetVolumeBackupPolicyAssetAssignment	

volume-backups

Verbs	Permissions	APIs Fully Covered	APIs Partially Covered
inspect	VOLUME_BACKUP_INSPECTNone		<p>GetVolumeGroupBackup (also need inspect volumes and volume-backups)</p> <p>ListVolumeGroupBackups (also need inspect volumes and volume-backups)</p> <p>ListVolumeBackups (also need inspect volumes and volume-backups)</p> <p>GetVolumeBackup (also need inspect volumes and volume- backups)</p> <p>GetBootVolumeBackup (also need inspect volumes and volume-backups)</p>
read	VOLUME_BACKUP_INSPECTNone VOLUME_BACKUP_READ		<p>GetVolumeGroupBackup (also need inspect volumes and volume-backups)</p> <p>ListVolumeGroupBackups (also need inspect volumes and volume-backups)</p> <p>ListVolumeBackups (also need inspect volumes and volume-backups)</p> <p>GetVolumeBackup (also need inspect volumes and volume- backups)</p> <p>GetBootVolumeBackup (also need inspect volumes and volume-backups)</p> <p>CreateVolume (also need manage volumes and read volume-backups)</p> <p>CreateVolumeGroup (also need manage volumes and read volume-backups)</p> <p>CopyVolumeBackup (also need use volume-backups)</p>

Verbs	Permissions	APIs Fully Covered	APIs Partially Covered
use	VOLUME_BACKUP_INSPECT VOLUME_BACKUP_READ VOLUME_BACKUP_UPDATE VOLUME_BACKUP_COPY	None	<p>GetVolumeGroupBackup (also need inspect volumes and volume-backups)</p> <p>ListVolumeGroupBackups (also need inspect volumes and volume-backups)</p> <p>ListVolumeBackups (also need inspect volumes and volume-backups)</p> <p>GetVolumeBackup (also need inspect volumes and volume- backups)</p> <p>GetBootVolumeBackup (also need inspect volumes and volume-backups)</p> <p>CreateVolume (also need manage volumes and read volume- backups)</p> <p>CreateVolumeGroup (also need manage volumes and read volume-backups)</p> <p>CopyVolumeBackup (also need use volume-backups)</p> <p>UpdateVolumeBackup (also need inspect volume and use volume-backups)</p> <p>UpdateVolumeGroupBackup (also need inspect volume and use volume-backups)</p> <p>UpdateBootVolumeBackup (also need inspect volume and use volume-backups)</p>

Verbs	Permissions	APIs Fully Covered	APIs Partially Covered
manage	VOLUME_BACKUP_INSPECT VOLUME_BACKUP_QUERY VOLUME_BACKUP_READ VOLUME_BACKUP_UPDATE VOLUME_BACKUP_COPY VOLUME_BACKUP_CREATE VOLUME_BACKUP_DELETE VOLUME_BACKUP_MOVE	DeleteVolumeBackup ChangeVolumeBackupCompartment	GetVolumeGroupBackup (also need inspect volumes and volume-backups) ListVolumeGroupBackups (also need inspect volumes and volume-backups) ListVolumeBackups (also need inspect volumes and volume-backups) GetVolumeBackup (also need inspect volumes and volume-backups) GetBootVolumeBackup (also need inspect volumes and volume-backups) CreateVolume (also need manage volumes and read volume-backups) CreateVolumeGroup (also need manage volumes and read volume-backups) CopyVolumeBackup (also need use volume-backups) UpdateVolumeBackup (also need inspect volume and use volume-backups) UpdateVolumeGroupBackup (also need inspect volume and use volume-backups) UpdateBootVolumeBackup (also need inspect volume and use volume-backups) CreateCrossRegionBackup (manage volume-backups and manage boot-volume-backups) CreateVolumeBackup (also need manage volume-backups and manage-volumes) CreateVolumeGroupBackup (also need manage volume-backups and manage-volumes) CreateBootVolumeBackup (also need manage volume-backups and manage-volumes) DeleteVolumeGroupBackup (also need manage volume-backups and inspect volumes) DeleteBootVolumeBackup (also need manage volume-backups and inspect volumes)

volume-groups

Verbs	Permissions	APIs Fully Covered	APIs Partially Covered
inspect	VOLUME_GROUP_INSPECT	None	None
read	VOLUME_GROUP_INSPECT	None	None
use	VOLUME_GROUP_INSPECT	None	None
manage	VOLUME_GROUP_CREATE	DeleteVolumeGroup	None
	VOLUME_GROUP_DELETE	ChangeVolumeGroupCompartment	
	VOLUME_GROUP_INSPECT		
	VOLUME_GROUP_MOVE		
	VOLUME_GROUP_UPDATE		

backup-policy-assignments

Verbs	Permissions	APIs Fully Covered	APIs Partially Covered
inspect	BACKUP_POLICY_ASSIGNMENT_INSPECT	GetVolumeBackupPolicyAssignment	GetVolumeBackupPolicyAssignment (also need inspect volumes and inspect backup-policy-assignments)
read	BACKUP_POLICY_ASSIGNMENT_INSPECT	GetVolumeBackupPolicyAssignment	None
use	BACKUP_POLICY_ASSIGNMENT_INSPECT	GetVolumeBackupPolicyAssignment	None
manage	BACKUP_POLICY_ASSIGNMENT_INSPECT	GetVolumeBackupPolicyAssignment	CreateVolumeBackupPolicyAssignment (also need inspect backup-policies)
	BACKUP_POLICY_ASSIGNMENT_CREATE	CreateVolumeBackupPolicyAssignment	
	BACKUP_POLICY_ASSIGNMENT_DELETE	DeleteVolumeBackupPolicyAssignment	

volume-group-backups

Verbs	Permissions	APIs Fully Covered	APIs Partially Covered
inspect	VOLUME_GROUP_BACKUP_INSPECT	None	None
read	VOLUME_GROUP_BACKUP_INSPECT	None	None
use	VOLUME_GROUP_BACKUP_INSPECT	None	None

Verbs	Permissions	APIs Fully Covered	APIs Partially Covered
manage	VOLUME_GROUP_BACKUP_INSPECT VOLUME_GROUP_BACKUP_MOVE VOLUME_GROUP_BACKUP_UPDATE VOLUME_GROUP_BACKUP_CREATE VOLUME_GROUP_BACKUP_DELETE	ChangeVolumeGroupBackupCompartment DeleteVolumeGroupBackup	None

boot-volume-backups

Verbs	Permissions	APIs Fully Covered	APIs Partially Covered
inspect	BOOT_VOLUME_BACKUP_INSPECT	None	ListBootVolumeBackups (also need inspect volumes) GetBootVolumeBackup (also need inspect volumes)
read	BOOT_VOLUME_BACKUP_INSPECT BOOT_VOLUME_BACKUP_READ	None	ListBootVolumeBackups (also need inspect volumes) GetBootVolumeBackup (also need inspect volumes) CreateBootVolume (also need manage volumes) CopyBootVolumeBackup (also need copy boot-volume-backups)

Verbs	Permissions	APIs Fully Covered	APIs Partially Covered
use	BOOT_VOLUME_BACKUP_INSPECT BOOT_VOLUME_BACKUP_READ BOOT_VOLUME_BACKUP_COPY BOOT_VOLUME_BACKUP_UPDATE	None	ListBootVolumeBackups (also need inspect volumes) GetBootVolumeBackup (also need inspect volumes) CreateBootVolume (also need manage volumes) CopyBootVolumeBackup (also need copy boot-volume-backups) UpdateBootVolumeBackup (also need inspect volumes)

Verbs	Permissions	APIs Fully Covered	APIs Partially Covered
manage	BOOT_VOLUME_BACKUP_INSPECT BOOT_VOLUME_BACKUP_READ BOOT_VOLUME_BACKUP_COPY BOOT_VOLUME_BACKUP_UPDATE BOOT_VOLUME_BACKUP_CREATE BOOT_VOLUME_BACKUP_DELETE BOOT_VOLUME_BACKUP_MOVE	ChangeBootVolumeBackupCompartment	ListBootVolumeBackups (also need inspect volumes) GetBootVolumeBackup (also need inspect volumes) CreateBootVolume (also need manage volumes) CopyBootVolumeBackup (also need copy boot-volume-backups) UpdateBootVolumeBackup (also need inspect volumes) CreateCrossRegionBackup (also need manage volume-backups) CreateBootVolumeBackup (also need use volumes) DeleteBootVolumeBackup (also need inspect volumes)

volume-attachments

Verbs	Permissions	APIs Fully Covered	APIs Partially Covered
manage	VOLUME_ATTACHMENT_CREATE	None	getVolumeAttachability (also need manage volumes) ValidateVolumeAttachability (also need manage volumes)

boot-volumes

Verbs	Permissions	APIs Fully Covered	APIs Partially Covered
manage	ListVolumeBackupPolicies	ChangeBootVolumeCompartment	None

volume-family

Verbs	Permissions	APIs Fully Covered	APIs Partially Covered
inspect	BACKUP_POLICIES_INSPECT	ListVolumeBackupPolicies	CreateVolumeBackupPolicyA
	BACKUP_POLICY_ASSIGNMENT_INSPECT	GetVolumeBackupPolicy	(also need manage backup-policy-assignments)
	BOOT_VOLUME_BACKUP_INSPECT	GetVolumeBackupPolicyAssignment	GetVolumeBackupPolicyAsse
	VOLUME_BACKUP_INSPECT	GetBootVolumeKmsKey	(also need inspect volumes)
	VOLUME_GROUP_BACKUP_INSPECT	ListVolumesGetVolume	ListBootVolumeBackups
	VOLUME_GROUP_INSPECT	GetVolumeGroup	(also need inspect volumes)
	VOLUME_INSPECT	ListVolumeGroups	ListVolumeGroupBackups
		GetBootVolume	(also need inspect volumes)
		ListBootVolumes	GetBootVolumeBackup
		ListVolumesHealth	(also need inspect volumes)
		GetVolumeHealth	GetVolumeGroupBackup
		GetVolumeKmsKey	(also need inspect volumes)
			ListVolumeGroupBackups
			ListVolumeBackups

Verbs	Permissions	APIs Fully Covered	APIs Partially Covered
read	BACKUP_POLICIES_INSPECT BACKUP_POLICY_ASSIGNMENT_INSPECT BOOT_VOLUME_BACKUP_INSPECT BOOT_VOLUME_BACKUP_READ VOLUME_BACKUP_READ VOLUME_GROUP_BACKUP_INSPECT VOLUME_GROUP_INSPECT VOLUME_INSPECT	CreateVolumeBackupPolicyAssignment (also need manage backup-policy-assignments) GetVolumeBackupPolicyAssignment (also need inspect volumes) ListBootVolumeBackups (also need inspect volumes) GetBootVolumeBackup (also need inspect volumes) GetVolumeGroupBackup (also need inspect volumes) ListVolumeGroupBackups (also need inspect volumes) ListVolumeBackups (also need inspect volumes) GetVolumeBackup (also need inspect volumes) DeleteVolumeBackup (also need manage volume-backups) UpdateVolumeGroupBackup (also need use volume-backups) DeleteVolumeGroupBackup (also need manage volume-backups) UpdateVolumeBackup (also need use volume-backups)	

Verbs	Permissions	APIs Fully Covered	APIs Partially Covered
use	BACKUP_POLICIES_INSPECT	UpdateBootVolumeKmsKey	CreateVolumeBackupPolicyA
	BACKUP_POLICY_ASSIGNMENT_INSPECT	DeleteBootVolumeKmsKey	(also need manage backup-policy-assignments)
	BOOT_VOLUME_BACKUP_COPY	UpdateVolumeGroup	GetVolumeBackupPolicyAssse
	BOOT_VOLUME_BACKUP_INSPECT	UpdateVolume	(also need inspect volumes)
	BOOT_VOLUME_BACKUP_READ	UpdateBootVolume	ListBootVolumeBackups
	BOOT_VOLUME_BACKUP_UPDATE	UpdateVolumeKmsKey	(also need inspect volumes)
	VOLUME_BACKUP_READ	DeleteVolumeKmsKey	GetBootVolumeBackup
	VOLUME_BACKUP_UPDATE		(also need inspect volumes)
	VOLUME_GROUP_BACKUP_INSPECT		GetVolumeGroupBackup
	VOLUME_GROUP_INSPECT		(also need inspect volumes)
	VOLUME_INSPECT		ListVolumeGroupBackups
			(also need inspect volumes)
			ListVolumeBackups
			(also need inspect volumes)
			GetVolumeBackup
			(also need inspect volumes)
			DeleteVolumeBackup
			(also need manage volume-backups)
			UpdateVolumeGroupBackup
			(also need use volume-backups)
			DeleteVolumeGroupBackup
			(also need manage volume-backups)
			UpdateVolumeBackup
			(also need use volume-backups)

Verbs	Permissions	APIs Fully Covered	APIs Partially Covered
manage	BACKUP_POLICIES_CREATE	UpdateBootVolumeKmsKey	CreateVolumeBackupPolicyA
	BACKUP_POLICIES_DELETE	DeleteBootVolumeKmsKey	(also need manage backup-policy-assignments)
	BACKUP_POLICIES_INSPECT	UpdateVolumeGroup	
	BACKUP_POLICIES_UPDATE	UpdateVolume	
	BACKUP_POLICY_ASSIGNMENT_CREATE	UpdateBootVolume	GetVolumeBackupPolicyAsse
	BACKUP_POLICY_ASSIGNMENT_DELETE	UpdateVolumeKmsKey	(also need inspect volumes)
	BACKUP_POLICY_ASSIGNMENT_INSPECT	DeleteVolumeKmsKey	
	BOOT_VOLUME_BACKUP_COPY	CreateVolumeBackupPolicy	ListBootVolumeBackups
	BOOT_VOLUME_BACKUP_CREATE	DeleteVolumeBackupPolicy	(also need inspect volumes)
	BOOT_VOLUME_BACKUP_DELETE	UpdateVolumeBackupPolicy	
	BOOT_VOLUME_BACKUP_INSPECT	DeleteVolumeBackupPolicyAssignment	GetBootVolumeBackup
	BOOT_VOLUME_BACKUP_MOVE	ChangeBootVolumeBackupCompartment	(also need inspect volumes)
	BOOT_VOLUME_BACKUP_READ	ChangeBootVolumeCompartment	
	BOOT_VOLUME_BACKUP_UPDATE	DeleteVolumeBackup	GetVolumeGroupBackup
	BOOT_VOLUME_CREATE	ChangeVolumeBackupCompartment	(also need inspect volumes)
	BOOT_VOLUME_DELETE	DeleteVolumeGroup	
	BOOT_VOLUME_MOVE	DeleteVolume	ListVolumeGroupBackups
	VOLUME_ATTACHMENT_CREATE	BatchDeleteVolumes	(also need inspect volumes)
	VOLUME_ATTACHMENT_DELETE	DeleteBootVolume	
	VOLUME_BACKUP_COPY	DeleteVolumeGroupBackup	ListVolumeBackups
	VOLUME_BACKUP_CREATE	ChangeVolumeGroupBackupCompartment	(also need inspect volumes)
	VOLUME_BACKUP_DELETE	ChangeVolumeGroupCompartment	
	VOLUME_BACKUP_MOVE	ChangeVolumeCompartment	GetVolumeBackup
	VOLUME_BACKUP_READ		(also need inspect volumes)
	VOLUME_BACKUP_UPDATE		
	VOLUME_CREATE		DeleteVolumeBackup
	VOLUME_DELETE		(also need manage volume-backups)
	VOLUME_GROUP_BACKUP_CREATE		
	VOLUME_GROUP_BACKUP_DELETE		
	VOLUME_GROUP_BACKUP_INSPECT		UpdateVolumeGroupBackup
	VOLUME_GROUP_BACKUP_MOVE		(also need use volume-backups)
	VOLUME_GROUP_BACKUP_UPDATE		
	VOLUME_GROUP_CREATE		DeleteVolumeGroupBackup
	VOLUME_GROUP_DELETE		(also need manage volume-backups)
	VOLUME_GROUP_INSPECT		
	VOLUME_GROUP_MOVE		
	VOLUME_GROUP_UPDATE		UpdateVolumeBackup
	VOLUME_INSPECT		(also need use volume-backups)

Certificates Permissions for Roving Edge Infrastructure

Describes the details for writing user IAM policies that control access to rules for the Certificates service for a Roving Edge Infrastructure device.

Resource-Types

leaf-certificates

leaf-certificates-csr

leaf-certificate-family

Details for Verb + Resource-Type Combinations

The following tables show the permissions and API operations covered by each verb. The level of access is cumulative as you go from inspect > read > use > manage.

leaf-certificates

Verbs	Permissions	APIs Fully Covered	APIs Partially Covered
inspect	CERTIFICATE_READ	ViewCertificate	None
		ViewCertificateWorkRequest	
read	CERTIFICATE_READ	ViewCertificate	None
		ViewCertificateWorkRequest	
manage	CERTIFICATE_READ	ViewCertificate	None
	CERTIFICATE_RENEW	ViewCertificateWorkRequest	
	CERTIFICATE_IMPORT	RenewCertificate	
	CERTIFICATE_CREATE	ImportCertificate CreateCertificate	

leaf-certificates-csr

Verbs	Permissions	APIs Fully Covered	APIs Partially Covered
inspect	CSR_READ	ViewCertificateSigningRequest	None
read	CSR_READ	ViewCertificateSigningRequest	None
manage	CSR_READ	ViewCertificateSigningRequest	None
	CSR_CREATE	CreateCertificateSigningRequest	

leaf-certificate-family

Verbs	Permissions	APIs Fully Covered	APIs Partially Covered
inspect	CERTIFICATE_READ	ViewCertificate	None
	CSR_READ	ViewCertificate	
		WorkRequest	
		ViewCertificate	
		SigningRequest	
read	CERTIFICATE_READ	ViewCertificate	None
	CSR_READ	ViewCertificate	
		WorkRequest	
		ViewCertificate	
		SigningRequest	
manage	CERTIFICATE_READ	ViewCertificate	None
	CERTIFICATE_RENEW	ViewCertificateWorkRequest	
	CERTIFICATE_IMPORT	RenewCertificate	
	CERTIFICATE_CREATE	ImportCertificate	
	CSR_READ	CreateCertificate	
	CSR_CREATE	ViewCertificateSigningRequest CreateCertificateSigningRequest	

Compute Permissions for Roving Edge Infrastructure

Describes the details for writing user IAM policies that control access to rules for the Compute service for a Roving Edge Infrastructure device.

Resource-Types

- instances
- console-histories
- instance-console-connections
- instance-images
- compute-work-request
- instance-family

Details for Verb + Resource-Type Combinations

The following tables show the permissions and API operations covered by each verb. The level of access is cumulative as you go from inspect > read > use > manage.

instances

Verbs	Permissions	APIs Fully Covered	APIs Partially Covered
inspect	INSTANCE_INSPECT	ListShapes ListInstances	GetConsoleHistory (also need inspect console-histories) ListConsoleHistories (also need inspect console-histories) ListVnicAttachments (also need read vnic-attachments) ListVolumeAttachments (also need inspect volumes and inspect volume-attachments) GetVolumeAttachment (also need inspect volumes and inspect volume-attachments) ListBootVolumeAttachments (also need inspect volumes and inspect volume-attachments) GetBootVolumeAttachment (also need inspect volumes and inspect volume-attachments) ListInstanceConsoleConnections (also need inspect instance-console-connections)

Verbs	Permissions	APIs Fully Covered	APIs Partially Covered
read	INSTANCE_INSPECT INSTANCE_READ	ListShapes ListInstances GetInstance GetWindowsInstanceInitialCredentials GetInstanceDefaultCredentials ListInstanceDevices	GetConsoleHistory (also need inspect console-histories) ListConsoleHistories (also need inspect console-histories) ListVnicAttachments (also need read vnic-attachments) ListVolumeAttachments (also need inspect volumes and inspect volume-attachments) GetVolumeAttachment (also need inspect volumes and inspect volume-attachments) ListBootVolumeAttachments (also need inspect volumes and inspect volume-attachments) GetBootVolumeAttachment (also need inspect volumes and inspect volume-attachments) ListInstanceConsoleConnections (also need inspect instance-console-connections) CaptureConsoleHistory (also need manage console-histories and read instance-images) GetConsoleHistoryContent (also need read console-histories and read instance-images) CreateInstanceConsoleConnection (also need manage instance-console-connections) GetInstanceConsoleConnection (also need read instance-console-connections)

Verbs	Permissions	APIs Fully Covered	APIs Partially Covered
use	INSTANCE_ATTACH_VOLUME	ListShapes	GetConsoleHistory (also need inspect console-histories)
	INSTANCE_CREATE_IMAGE	ListInstances	ListConsoleHistories (also need inspect console-histories)
	INSTANCE_DETACH_VOLUME	GetInstance	ListVnicAttachments (also need read vnic-attachments)
	INSTANCE_INSPECT	GetWindowsInstanceInitialCredentials	ListVolumeAttachments (also need inspect volumes and inspect volume-attachments)
	INSTANCE_POWER_ACTIONS	GetInstanceDefaultCredentials	GetVolumeAttachment (also need inspect volumes and inspect volume-attachments)
	INSTANCE_READ	ListInstanceDevices	ListBootVolumeAttachments (also need inspect volumes and inspect volume-attachments)
	INSTANCE_UPDATE	InstanceAction	GetBootVolumeAttachment (also need inspect volumes and inspect volume-attachments)
		UpdateInstance	ListInstanceConsoleConnections (also need inspect instance-console-connections)
			CaptureConsoleHistory (also need manage console-histories and read instance-images)
			GetConsoleHistoryContent (also need read console-histories and read instance-images)
			CreateInstanceConsoleConnection (also need manage instance-console-connections)
			GetInstanceConsoleConnection (also need read instance-console-connections)
			AttachBootVolume (also need inspect volumes and inspect volume-attachments)

Verbs	Permissions	APIs Fully Covered	APIs Partially Covered
manage	INSTANCE_ATTACH_SECONDARY_VNIC	VnicShapes	GetConsoleHistory (also need inspect console-histories)
	INSTANCE_ATTACH_VOLUME	ListInstances	ListConsoleHistories (also need inspect console-histories)
	INSTANCE_CREATE	GetInstance	ListVnicAttachments (also need read vnic-attachments)
	INSTANCE_CREATE_IMAGE	GetWindowsInstanceInitialCredentials	ListVolumeAttachments (also need inspect volumes and inspect volume-attachments)
	INSTANCE_DELETE	GetInstanceDefaultCredentials	GetVolumeAttachment (also need inspect volumes and inspect volume-attachments)
	INSTANCE_DETACH_SECONDARY_VNIC	GetInstanceDevices	ListBootVolumeAttachments (also need inspect volumes and inspect volume-attachments)
	INSTANCE_DETACH_VOLUME	InstanceAction	GetBootVolumeAttachment (also need inspect volumes and inspect volume-attachments)
	INSTANCE_INSPECT	UpdateInstance	ListInstanceConsoleConnections (also need inspect instance-console-connections)
	INSTANCE_MOVE		CaptureConsoleHistory (also need manage console-histories and read instance-images)
	INSTANCE_POWER_ACTIONS		GetConsoleHistoryContent (also need read console-histories and read instance-images)
	INSTANCE_READ		CreateInstanceConsoleConnection (also need manage instance-console-connections)
	INSTANCE_UPDATE		GetInstanceConsoleConnection (also need read instance-console-connections)
	COMPUTE_WORK_REQUEST_CREATE		
	COMPUTE_WORK_REQUEST_INSPECT		
	COMPUTE_WORK_REQUEST_READ		

console-histories

Verbs	Permissions	APIs Fully Covered	APIs Partially Covered
inspect	CONSOLE_HISTORY_INSPECT	None	GetConsoleHistory (also need inspect instances) ListConsoleHistories (also need inspect instances)
read	CONSOLE_HISTORY_INSPECT COMPUTE_WORK_REQUEST_READ	None	GetConsoleHistory (also need inspect instances) ListConsoleHistories (also need inspect instances) GetConsoleHistoryContent (also need read instances and read instance-images)
use	CONSOLE_HISTORY_INSPECT COMPUTE_WORK_REQUEST_READ	None	GetConsoleHistory (also need inspect instances) ListConsoleHistories (also need inspect instances) GetConsoleHistoryContent (also need read instances and read instance-images)
manage	CONSOLE_HISTORY_INSPECT CONSOLE_HISTORY_READ CONSOLE_HISTORY_CREATE CONSOLE_HISTORY_DELETE	DeleteConsoleHistory UpdateConsoleHistory	GetConsoleHistory (also need inspect instances) ListConsoleHistories (also need inspect instances) GetConsoleHistoryContent (also need read instances and read instance-images) CaptureConsoleHistory (also need read instances and read instance-images)

instance-console-connections

Verbs	Permissions	APIs Fully Covered	APIs Partially Covered
inspect	INSTANCE_CONSOLE_CONNECTION_INSPECT	None	ListInstanceConsoleConnections (also need inspect instances)
read	INSTANCE_CONSOLE_CONNECTION_INSPECT INSTANCE_CONSOLE_CONNECTION_READ	None	ListInstanceConsoleConnections (also need inspect instances) GetInstanceConsoleConnection (also need read instances)

Verbs	Permissions	APIs Fully Covered	APIs Partially Covered
use	INSTANCE_CONSOLE_CONNECTION_INSPECT INSTANCE_CONSOLE_CONNECTION_READ	None	ListInstanceConsoleConnections (also need inspect instances) GetInstanceConsoleConnection (also need read instances)
manage	INSTANCE_CONSOLE_CONNECTION_INSPECT INSTANCE_CONSOLE_CONNECTION_DELETE INSTANCE_CONSOLE_CONNECTION_UPDATE INSTANCE_CONSOLE_CONNECTION_CREATE INSTANCE_CONSOLE_CONNECTION_DELETE	UpdateInstanceConsoleConnection DeleteInstanceConsoleConnection	ListInstanceConsoleConnections (also need inspect instances) GetInstanceConsoleConnection (also need read instances) CreateInstanceConsoleConnection (also need read instances)

instance-images

Verbs	Permissions	APIs Fully Covered	APIs Partially Covered
inspect	INSTANCE_IMAGE_INSPECT	ListImages GetImage GetImageShapeCompatibility ListImageShapeCompatibilities	None

Verbs	Permissions	APIs Fully Covered	APIs Partially Covered
read	INSTANCE_CONSOLE_CONNECTION_INSPECT INSTANCE_CONSOLE_CONNECTION_READ	Inspect GetImage GetImageShapeCompatibility ListImageShapeCompatibilities	LaunchInstance (also need manage instances, manage instance-images, use vnics, and use subnets) CaptureConsoleHistory (also need read console-histories and read instances) GetConsoleHistoryContent (also need read console-histories and read instances) ExportImage (also need manage objects)
use	INSTANCE_IMAGE_INSPECT INSTANCE_IMAGE_READ INSTANCE_IMAGE_UPDATE	ListImages GetImage GetImageShapeCompatibility ListImageShapeCompatibilities UpdateImage AddImageShapeCompatibility RemoveImageShapeCompatibility	LaunchInstance (also need manage instances, manage instance-images, use vnics, and use subnets) CaptureConsoleHistory (also need read console-histories and read instances) GetConsoleHistoryContent (also need read console-histories and read instances) ExportImage (also need manage objects)

Verbs	Permissions	APIs Fully Covered	APIs Partially Covered
manage	INSTANCE_IMAGE_INSPECT INSTANCE_IMAGE_READ INSTANCE_IMAGE_UPDATE INSTANCE_IMAGE_MOVE INSTANCE_IMAGE_CREATE INSTANCE_IMAGE_DELETE COMPUTE_WORK_REQUEST_CREATE COMPUTE_WORK_REQUEST_DELETE COMPUTE_WORK_REQUEST_INSPECT COMPUTE_WORK_REQUEST_READ	ListImages GetImage GetImageShapeCompatibility ListImageShapeCompatibilities UpdateImage AddImageShapeCompatibility RemoveImageShapeCompatibility DeleteImage	LaunchInstance (also need manage instances, manage instance-images, use vnics, and use subnets) CaptureConsoleHistory (also need read console-histories and read instances) GetConsoleHistoryContent (also need read console-histories and read instances) CreateImage (also need use instances, manage instances, and manage instance-images) TerminateInstance (also need use vnics, use subnets, and manage instances; also need manage volume-attachments and use volumes if a volume is attached) GetWorkRequest, ListWorkRequestErrors, and ListWorkRequestLogs (for work requests related to instance-images resource types. All also need the permissions for CreateImage)

compute-work-request

Verbs	Permissions	APIs Fully Covered	APIs Partially Covered
inspect	COMPUTE_WORK_REQUEST_INSPECT	ListWorkrequests	None
read	COMPUTE_WORK_REQUEST_READ	ListWorkrequests GetWorkRequest ListWorkrequestErrors ListWorkrequestLogs	None

instance-family

Verbs	Permissions	APIs Fully Covered	APIs Partially Covered	
inspect	INSTANCE_INSPECT	ListShapes	ListVolumeAttachments (also need inspect volumes)	
	CONSOLE_HISTORY_INSPECT	ListInstances		
	INSTANCE_CONSOLE_CONNECTION_INSPECT	GetInstanceConsoleHistory		
	INSTANCE_IMAGE_INSPECT	ListConsoleHistories	GetVolumeAttachment (also need inspect volumes)	
	VNIC_READ	ListImages		
	VNIC_ATTACHMENT_READ	ListInstanceConsoleConnections		
	VOLUME_ATTACHMENT_INSPECT		GetImage GetImageShapeCompatibility ListImageShapeCompatibilities	ListBootVolumeAttachments (also need inspect volumes)
			ListVnicAttachments	GetBootVolumeAttachments (also need inspect volumes)

Verbs	Permissions	APIs Fully Covered	APIs Partially Covered
read	INSTANCE_INSPECT	ListShapes	ListVolumeAttachments (also need inspect volumes)
	INSTANCE_READ	ListInstances	
	CONSOLE_HISTORY_INSPECT	GetInstance	
	CONSOLE_HISTORY_READ	GetWindowsInstanceInitialCredentials	GetVolumeAttachment (also need inspect volumes)
	INSTANCE_CONSOLE_CONNECTION_INSPECT	GetInstanceDefaultCredentials	
	INSTANCE_CONSOLE_CONNECTION_READ	ListInstanceDevices	
	INSTANCE_IMAGE_INSPECT	GetConsoleHistoryContent	ListBootVolumeAttachments (also need inspect volumes)
	INSTANCE_IMAGE_READ	ListConsoleHistories	
	VNIC_READ	GetInstanceConsoleConnection	
	VNIC_ATTACHMENT_READ	ListInstanceConsoleConnections	GetBootVolumeAttachment (also need inspect volumes)
	VOLUME_ATTACHMENT_INSPECT	ListImages	
	VOLUME_ATTACHMENT_READ	GetImage	
		GetImageShapeCompatibility	CaptureConsoleHistory (also need manage console-histories)
		ListImageShapeCompatibilities	
		ListVnicAttachments	CreateInstanceConsoleConn (also need manage instance-console-connections)
		LaunchInstance (also need manage instances, manage instance-images, use vnics, and use subnets)	
		ExportImage (also need manage objects)	

Verbs	Permissions	APIs Fully Covered	APIs Partially Covered
use	INSTANCE_ATTACH_VOLUME	ListShapes	ListVolumeAttachments (also need inspect volumes)
	INSTANCE_CREATE_IMAGE	ListInstances	GetVolumeAttachment (also need inspect volumes)
	INSTANCE_DETACH_VOLUME	GetInstance	ListBootVolumeAttachments (also need inspect volumes)
	INSTANCE_INSPECT	GetWindowsInstanceInitialCredentials	GetBootVolumeAttachment (also need inspect volumes)
	INSTANCE_POWER_ACTIONS	GetInstanceDefaultCredentials	ListInstanceConsoleConnections (also need inspect volumes)
	INSTANCE_READ	ListInstanceDevices	CaptureConsoleHistory (also need manage console-histories)
	INSTANCE_UPDATE	InstanceAction	CreateInstanceConsoleConnections (also need manage instance-console-connections)
	CONSOLE_HISTORY_INSPECT	UpdateInstance	AttachBootVolume (also need manage volume-attachments)
	CONSOLE_HISTORY_READ	GetConsoleHistoryContent	AttachVolume (also need manage volume-attachments)
	INSTANCE_CONSOLE_CONNECTION_INSPECT	ListInstanceConsoleHistories	CreateImage (also need manage instance-images and manage instances)
	INSTANCE_CONSOLE_CONNECTION_READ	GetInstanceConsoleConnection	DetachBootVolume (also need manage volume-attachments)
	INSTANCE_IMAGE_INSPECT	ListInstanceConsoleConnections	DetachVolume (also need manage volume-attachments)
	INSTANCE_IMAGE_READ	ListImages	
	INSTANCE_IMAGE_UPDATE	GetImage	
	VNIC_READ	GetImageShapeCompatibility	
	VNIC_ATTACHMENT_READ	ListImageShapeCompatibilities	
	VOLUME_ATTACHMENT_INSPECT	UpdateImage	
	VOLUME_ATTACHMENT_READ	AddImageShapeCompatibility	
	VNIC_ATTACH	RemoveImageShapeCompatibility	
	VNIC_DETACH	ListVnicAttachments	
VOLUME_ATTACHMENT_UPDATE			

Verbs	Permissions	APIs Fully Covered	APIs Partially Covered
manage	INSTANCE_ATTACH_SECONDARY_VNIC	ListInstanceShapes	ListVolumeAttachments (also need inspect volumes)
	INSTANCE_ATTACH_VOLUME	ListInstances	
	INSTANCE_CREATE	GetInstance	
	INSTANCE_CREATE_IMAGE	GetWindowsInstanceInitialCredentials	GetVolumeAttachment (also need inspect volumes)
	INSTANCE_DELETE	GetInstanceDefaultCredentials	
	INSTANCE_DETACH_SECONDARY_VNIC	ListInstanceDevices	
	INSTANCE_DETACH_VOLUME	InstanceAction	ListBootVolumeAttachments (also need inspect volumes)
	INSTANCE_INSPECT	UpdateInstance	
	INSTANCE_MOVE	CaptureConsoleHistory	
	INSTANCE_POWER_ACTIONS	GetConsoleHistoryContent	GetBootVolumeAttachments (also need inspect volumes)
	INSTANCE_READ	ListConsoleHistories	
	INSTANCE_UPDATE	DeleteConsoleHistory	
	COMPUTE_WORK_REQUEST_CREATE	UpdateConsoleHistory	LaunchInstance (also need use subnets and use vnics)
	COMPUTE_WORK_REQUEST_INSPECT	CreateInstanceConsoleConnection	
	COMPUTE_WORK_REQUEST_READ	GetInstanceConsoleConnection	
	CONSOLE_HISTORY_CREATE	ListInstanceConsoleConnections	
	CONSOLE_HISTORY_DELETE	UpdateInstanceConsoleConnection	TerminateInstance (also need use subnets, and use vnics)
	CONSOLE_HISTORY_INSPECT	DeleteInstanceConsoleConnection	
	CONSOLE_HISTORY_READ	CreateImage	
	INSTANCE_CONSOLE_CONNECTION_CREATE	ListImages	AttachVnic (also need use subnets and use vcn)
	INSTANCE_CONSOLE_CONNECTION_DELETE	DeleteImage	
	INSTANCE_CONSOLE_CONNECTION_INSPECT	GetInstanceShapeCompatibility	
	INSTANCE_CONSOLE_CONNECTION_READ	ListImageShapeCompatibilities	
	INSTANCE_CONSOLE_CONNECTION_UPDATE	CreateImage	DetachVnic (also need use subnets)
	INSTANCE_IMAGE_CREATE	AddImageShapeCompatibility	
	INSTANCE_IMAGE_DELETE	RemoveImageShapeCompatibility	ExportImage (also need manage objects)
	INSTANCE_IMAGE_INSPECT	DeleteImage	
	INSTANCE_IMAGE_MOVE	ListWorkrequests	
	INSTANCE_IMAGE_READ	GetWorkRequest	
	INSTANCE_IMAGE_UPDATE	ListWorkrequestErrors	
	VNIC_READ	ListWorkrequestLogs	
	VNIC_ATTACHMENT_READ	ListVnicAttachments	
	VOLUME_ATTACHMENT_INSPECT	AttachBootVolume	
	VOLUME_ATTACHMENT_READ	AttachVolume	
	VNIC_ATTACH	DetachBootVolume	
	VNIC_DETACH		
	VOLUME_ATTACHMENT_UPDATE		
	VOLUME_ATTACHMENT_CREATE		
	VOLUME_ATTACHMENT_DELETE		

Data Synchronization Permissions for Roving Edge Infrastructure

Describes the details for writing user IAM policies that control access to rules for the data synchronization capability of a Roving Edge Infrastructure device.

Resource-Types

`datasync`

`taskdefinition`

Details for Verb + Resource-Type Combinations

The following tables show the permissions and API operations covered by each verb. The level of access is cumulative as you go from `inspect` > `read` > `use` > `manage`.

datasync

Sub-Component	Verbs	Permissions	APIs Fully Covered	APIs Partially Covered
datasync	inspect	DATA_SYNC_TASK_READ	getTasks	None
	read	DATA_SYNC_TASK_READ	getTasks	None
	use	DATA_SYNC_TASK_READ	getTasks	None
	manage	DATA_SYNC_TASK_READ DATA_SYNC_TASK_CREATE DATA_SYNC_TASK_DELETE	createTaskgetTasks cancelTask	None

taskdefinition

Sub-Component	Verbs	Permissions	APIs Fully Covered	APIs Partially Covered
taskdefinition	inspect	DATA_SYNC_TASK_DEF_INSPECT	listTaskDefinitions	None
	read	DATA_SYNC_TASK_DEF_INSPECT	listTaskDefinitions	None
		DATA_SYNC_TASK_DEF_READ	getTaskDefinition	
	use	DATA_SYNC_TASK_DEF_INSPECT	listTaskDefinitions	None
		DATA_SYNC_TASK_DEF_READ	getTaskDefinition	
		DATA_SYNC_TASK_DEF_UPDATE	updateTaskDefinition	
	manage	DATA_SYNC_TASK_DEF_INSPECT	createTaskDefinition	None
		DATA_SYNC_TASK_DEF_READ	deleteTaskDefinition	
		DATA_SYNC_TASK_DEF_UPDATE	listTaskDefinitions	
		DATA_SYNC_TASK_DEF_CREATE	getTaskDefinition	
		DATA_SYNC_TASK_DEF_DELETE	updateTaskDefinition	

Diagnostics Permissions for Roving Edge Infrastructure

Describes the details for writing user IAM policies that control access to rules for the diagnostics capability of a Roving Edge Infrastructure device.

Resource-Types

diag-bundle

diag-command

diag-family

Details for Verb + Resource-Type Combinations

The following tables show the permissions and API operations covered by each verb. The level of access is cumulative as you go from `inspect` > `read` > `use` > `manage`.

diag-bundle

Verbs	Permissions	APIs Fully Covered	APIs Partially Covered
inspect	DIAG_BUNDLE_READ	ListDiagBundles	None
		GetDiagBundle	
		ViewDiagBundleSummary	
read	DIAG_BUNDLE_READ	ListDiagBundles	None
		GetDiagBundle	
		ViewDiagBundleSummary	
use	DIAG_BUNDLE_READ	ListDiagBundles	None
		GetDiagBundle	
		ViewDiagBundleSummary	
manage	DIAG_BUNDLE_READ	CreateDiagBundle	None
	DIAG_BUNDLE_CREATE	ListDiagBundles	
	DIAG_BUNDLE_DELETE	CancelDiagBundle	
		GetDiagBundle	
		ViewDiagBundleSummary	

diag-command

Verbs	Permissions	APIs Fully Covered	APIs Partially Covered
inspect	DIAG_COMMAND_READ	ListDiagCommands	None
		GetDiagCommand	
		ViewDiagCommandSummary	

Verbs	Permissions	APIs Fully Covered	APIs Partially Covered
read	DIAG_COMMAND_READ	ListDiagCommands GetDiagCommand ViewDiagCommandSummary	None
use	DIAG_COMMAND_READ	ListDiagCommands GetDiagCommand ViewDiagCommandSummary	None
manage	DIAG_COMMAND_READ DIAG_COMMAND_CREATE DIAG_COMMAND_DELETE	CreateDiagCommand ListDiagCommands CancelDiagCommand GetDiagCommand ViewDiagCommandSummary	None

diag-family

Verbs	Permissions	APIs Fully Covered	APIs Partially Covered
inspect	DIAG_BUNDLE_READ DIAG_COMMAND_READ	ListDiagBundles GetDiagBundle ViewDiagBundleSummary ListDiagCommands GetDiagCommand ViewDiagCommandSummary	None
read	DIAG_BUNDLE_READ DIAG_COMMAND_READ	ListDiagBundles GetDiagBundle ViewDiagBundleSummary ListDiagCommands GetDiagCommand ViewDiagCommandSummary	None
use	DIAG_BUNDLE_READ DIAG_COMMAND_READ	ListDiagBundles GetDiagBundle ViewDiagBundleSummary ListDiagCommands GetDiagCommand ViewDiagCommandSummary	None

Verbs	Permissions	APIs Fully Covered	APIs Partially Covered	
manage	DIAG_BUNDLE_READ	CreateDiagBundle	None	
	DIAG_BUNDLE_CREATE	ListDiagBundles		
	DIAG_BUNDLE_DELETE	CancelDiagBundle		
	DIAG_COMMAND_READ	GetDiagBundle		
	DIAG_COMMAND_CREATE	ViewDiagBundleSummary		
	DIAG_COMMAND_DELETE			CreateDiagCommand
				ListDiagCommands
				CancelDiagCommand
				GetDiagCommand
ViewDiagCommandSummary				

Events Permissions for Roving Edge Infrastructure

Describes the details for writing user IAM policies that control access to rules for the Events service for a Roving Edge Infrastructure device.

Resource-Types

cloudevents-rules

cloudevents-family

Details for Verb + Resource-Type Combinations

The following tables show the permissions and API operations covered by each verb. The level of access is cumulative as you go from `inspect` > `read` > `use` > `manage`.

cloudevents-rules

Verbs	Permissions	APIs Fully Covered	APIs Partially Covered
inspect	EVENTRULE_LIST	ListRules	None
		ListSchemas	
read	EVENTRULE_LIST	ListRules	None
	EVENTRULE_READ	ListSchemas	
		GetRule	
use	EVENTRULE_LIST	ListRules	None
	EVENTRULE_READ	ListSchemas	
		GetRule	

Verbs	Permissions	APIs Fully Covered	APIs Partially Covered
manage	EVENTRULE_LIST	ListRules	None
	EVENTRULE_READ	ListSchemas	
	EVENTRULE_MODIFY	GetRule	
	EVENTRULE_CREATE	ChangeRuleCompartment	
	EVENTRULE_DELETE	UpdateRule	
		CreateRule	
		DeleteRule	

cloudevents-family

Verbs	Permissions	APIs Fully Covered	APIs Partially Covered
inspect	EVENTRULE_LIST	ListRules	None
		ListSchemas	
read	EVENTRULE_LIST	ListRules	None
	EVENTRULE_READ	ListSchemas	
		GetRule	
use	EVENTRULE_LIST	ListRules	None
	EVENTRULE_READ	ListSchemas	
	EVENT_CONSUME	GetRule	
manage	EVENTRULE_LIST	ListRules	None
	EVENTRULE_READ	ListSchemas	
	EVENTRULE_MODIFY	GetRule	
	EVENTRULE_CREATE	ChangeRuleCompartment	
	EVENTRULE_DELETE	UpdateRule	
	EVENT_CONSUME	CreateRule	
	EVENT_PUBLISH	DeleteRule	

Identity and Access Management Permissions for Roving Edge Infrastructure

Describes the details for writing user IAM policies that control access to rules for the Identity and Access Management service for a Roving Edge Infrastructure device.

Resource-Types

- groups
- policies
- users
- lockout-policies

Details for Verb + Resource-Type Combinations

The following tables show the permissions and API operations covered by each verb. The level of access is cumulative as you go from `inspect` > `read` > `use` > `manage`.

groups

Verbs	Permissions	APIs Fully Covered	APIs Partially Covered
inspect	GROUP_INSPECT	ListGroups	ListUserGroupMembership (also needs USER_INSPECT)
		GetGroups	GetUserGroupMembership (also needs USER_INSPECT)
read	GROUP_INSPECT	ListGroups	None
		GetGroups	
use	GROUP_INSPECT	ListGroups	AddUserToGroup (also needs USER_UPDATE)
	GROUP_UPDATE	GetGroups	
		UpdateGroup	RemoveUserFromGroup (also needs USER_UPDATE)
manage	GROUP_INSPECT	ListGroups	None
	GROUP_UPDATE	GetGroups	
	GROUP_CREATE	UpdateGroup	
	GROUP_DELETE	CreateGroup	
		DeleteGroup	

policies

Verbs	Permissions	APIs Fully Covered	APIs Partially Covered
inspect	POLICY_READ	ListPolicies	None
		GetPolicies	
read	POLICY_READ	ListPolicies	None
		GetPolicies	
use	POLICY_READ	ListPolicies	None
		GetPolicies	
manage	POLICY_READ	ListPolicies	None
	POLICY_UPDATE	GetPolicies	
	POLICY_CREATE	UpdatePolicy	
	POLICY_DELETE	CreatePolicy	
		DeletePolicy	

users

Verbs	Permissions	APIs Fully Covered	APIs Partially Covered
inspect	USER_INSPECT	ListUsers	ListUserGroupMembership (also needs GROUP_INSPECT)
		GetUser	GetUserGroupMembership (also needs GROUP_INSPECT)
read	USER_INSPECT	ListUsers	None
	USER_READ	GetUser	
		ListApiKeys	
		ListAuthTokens	
		ListOauth2ClientCredentials	
		ListCustomerSecretKeys	
use	USER_INSPECT	ListUsers	AddUserToGroup (also needs GROUP_UPDATE)
	USER_READ	GetUser	RemoveUserFromGroup (also needs GROUP_UPDATE)
	USER_UPDATE	ListApiKeys	
		ListAuthTokens	
		ListOauth2ClientCredentials	
		ListCustomerSecretKeys	
		UpdateUser	

Verbs	Permissions	APIs Fully Covered	APIs Partially Covered
manage	USER_APIKEY_ADD	ListUsers	None
	USER_APIKEY_REMOVE	GetUser	
	USER_AUTHTOKEN_REMOVE	ListApiKeys	
	USER_AUTHTOKEN_RESET	ListAuthTokens	
	USER_AUTHTOKEN_SET	ListOauth2ClientCredentials	
	USER_CAPABILITIES_UPDATE	ListCustomerSecretKeys	
	USER_CREATE	UpdateUser	
	USER_DELETE	UploadApiKey	
	USER_INSPECT	DeleteApiKey	
	USER_OAUTH2_CLIENT_CRED_CREATE	DeleteAuthToken	
	USER_OAUTH2_CLIENT_CRED_UPDATE	DeleteAuthToken	
	USER_OAUTH2_CLIENT_CRED_REMOVE	DeleteAuthToken	
	USER_READ	UpdateUserCapabilities	
	USER_SECRETKEY_ADD	CreateUser	
	USER_SECRETKEY_REMOVE	DeleteUser	
	USER_SECRETKEY_UPDATE	CreateOauth2ClientCredential	
	USER_UNBLOCK	UpdateOauth2ClientCredential	
	USER_UPDATE	DeleteOauth2ClientCredential	
		CreateCustomerSecretKey	
		DeleteCustomerSecretKey	
	UpdateCustomerSecretKey		
	UpdateUserState		

lockout-policies

Verbs	Permissions	APIs Fully Covered	APIs Partially Covered
inspect	LOCKOUT_POLICY_INSPECT	ListLockoutPolicies	None
read	LOCKOUT_POLICY_INSPECT	ListLockoutPolicies	None
	LOCKOUT_POLICY_READ	GetLockoutPolicy	
use	LOCKOUT_POLICY_INSPECT	ListLockoutPolicies	None
	LOCKOUT_POLICY_READ	GetLockoutPolicy	
	LOCKOUT_POLICY_UPDATE	UpdateLockoutPolicy	

Verbs	Permissions	APIs Fully Covered	APIs Partially Covered
manage	LOCKOUT_POLICY_INSPECT	ListLockoutPolicies	None
	LOCKOUT_POLICY_READ	GetLockoutPolicy	
	LOCKOUT_POLICY_UPDATE	UpdateLockoutPolicy	

Monitoring Permissions for Roving Edge Infrastructure

Describes the details for writing user IAM policies that control access to rules for the Monitoring service for a Roving Edge Infrastructure device.

Resource-Types

servicestatuslist

servicestatussummary

osoverview

Details for Verb + Resource-Type Combinations

The following tables show the permissions and API operations covered by each verb. The level of access is cumulative as you go from inspect > read > use > manage.

servicestatuslist

Verbs	Permissions	APIs Fully Covered	APIs Partially Covered
inspect	MONITOR_SERVICE_STATUS_LIST	GetServiceStatusList	None
read	MONITOR_SERVICE_STATUS_LIST	GetServiceStatusList	None
use	MONITOR_SERVICE_STATUS_LIST	GetServiceStatusList	None
manage	MONITOR_SERVICE_STATUS_LIST	GetServiceStatusList	None

servicestatussummary

Verbs	Permissions	APIs Fully Covered	APIs Partially Covered
inspect	MONITOR_SERVICE_STATUS_SUMMARY_LIST	GetServiceStatusSummary	None
read	MONITOR_SERVICE_STATUS_SUMMARY_LIST	GetServiceStatusSummary	None
use	MONITOR_SERVICE_STATUS_SUMMARY_LIST	GetServiceStatusSummary	None
manage	MONITOR_SERVICE_STATUS_SUMMARY_LIST	GetServiceStatusSummary	None

osdoverview

Verbs	Permissions	APIs Fully Covered	APIs Partially Covered
inspect	MONITOR_OSD_LIST	GetOsdOverview	None
read	MONITOR_OSD_LIST	GetOsdOverview	None
use	MONITOR_OSD_LIST	GetOsdOverview	None
manage	MONITOR_OSD_LIST	GetOsdOverview	None

Networking Permissions for Roving Edge Infrastructure

Describes the details for writing user IAM policies that control access to rules for the Networking service for a Roving Edge Infrastructure device.

Resource-Types

- subnets
- vnic-attachments
- vcns
- route-tables
- public-ips
- network-security-group
- security-lists
- private-ips
- dhcp-options
- vnics

Details for Verb + Resource-Type Combinations

The following tables show the permissions and API operations covered by each verb. The level of access is cumulative as you go from inspect > read > use > manage.

subnets

Verbs	Permissions	APIs Fully Covered	APIs Partially Covered
inspect	SUBNET_READ	ListSubnets	None
		GetSubnet	
read	SUBNET_READ	ListSubnets	None
		GetSubnet	

Verbs	Permissions	APIs Fully Covered	APIs Partially Covered
use	SUBNET_READ SUBNET_ATTACH SUBNET_DETACH	ListSubnets GetSubnet	LaunchInstance (also need use vnics, use network-security-groups, and manage instance-family) TerminateInstance (also need manage instance-family, and use volumes if a volume is attached) AttachVnic (also need manage instances, use network-security-groups, and either use vnics or use instance-family) DetachVnic (also need manage instances and either use vnics or use instance-family) CreatePrivateIp, DeletePrivateIp (both also need use private-ips and use vnics)
manage	SUBNET_READ SUBNET_ATTACH SUBNET_DETACH SUBNET_CREATE SUBNET_DELETE SUBNET_MOVE SUBNET_UPDATE	ListSubnets GetSubnet	LaunchInstance (also need use vnics, use network-security-groups, and manage instance-family) TerminateInstance (also need manage instance-family, and use volumes if a volume is attached) AttachVnic (also need manage instances, use network-security-groups, and either use vnics or use instance-family) DetachVnic (also need manage instances and either use vnics or use instance-family) CreatePrivateIp, DeletePrivateIp (both also need use private-ips and use vnics) CreateSubnet, DeleteSubnet (both also need manage vcn, manage route-tables, manage security-lists, manage dhcp-options) UpdateSubnet Note: The above operations in this cell are covered with just manage virtual-network-family.

vnic-attachments

Verbs	Permissions	APIs Fully Covered	APIs Partially Covered
inspect	VNIC_ATTACHMENT_READ	GetVnicAttachment	ListVnicAttachments CreateInstanceConfiguration (if using the CreateInstanceConfigurationFromInstanceConfiguration subtype. Also need read instances, inspect vnics, inspect volumes, and inspect volume-attachments.)
read	VNIC_ATTACHMENT_READ	None	ListVnicAttachments CreateInstanceConfiguration (if using the CreateInstanceConfigurationFromInstanceConfiguration subtype. Also need read instances, inspect vnics, inspect volumes, and inspect volume-attachments.)
use	VNIC_ATTACHMENT_READ	None	ListVnicAttachments CreateInstanceConfiguration (if using the CreateInstanceConfigurationFromInstanceConfiguration subtype. Also need read instances, inspect vnics, inspect volumes, and inspect volume-attachments.)
manage	VNIC_ATTACHMENT_READ	None	ListVnicAttachments CreateInstanceConfiguration (if using the CreateInstanceConfigurationFromInstanceConfiguration subtype. Also need read instances, inspect vnics, inspect volumes, and inspect volume-attachments.)

vcns

Verbs	Permissions	APIs Fully Covered	APIs Partially Covered
inspect	VCN_READ	ListVcns GetVcn	None

Verbs	Permissions	APIs Fully Covered	APIs Partially Covered
read	VCN_READ	ListVcns GetVcn	None
use	VCN_READ	ListVcns GetVcn	None
manage	VCN_READ VCN_ATTACH VCN_DETACH VCN_UPDATE VCN_CREATE VCN_DELETE VCN_MOVE	ListVcns CreateVcn UpdateVcn DeleteVcn, AddVcnCidr ModifyVcnCidr RemoveVcnCidr	CreateSubnet, DeleteSubnet (both also need manage route-tables and manage-security-lists and manage-dhcp-options)

route-tables

Verbs	Permissions	APIs Fully Covered	APIs Partially Covered
inspect	ROUTE_TABLE_READ	ListRouteTables GetRouteTable	None
read	ROUTE_TABLE_READ	ListRouteTables GetRouteTable	None
use	ROUTE_TABLE_READ	ListRouteTables GetRouteTable	None
manage	ROUTE_TABLE_READ ROUTE_TABLE_UPDATE ROUTE_TABLE_ATTACH ROUTE_TABLE_DETACH ROUTE_TABLE_MOVE ROUTE_TABLE_CREATE ROUTE_TABLE_DELETE	ListRouteTables GetRouteTable	CreateSubnet, DeleteSubnet (both also need manage vcns, manage subnets, manage security-lists, manage dhcp-options) UpdateSubnet (if changing which route table is associated with the subnet, also need manage subnets) Note: All of the above operations in this cell are totally covered with just manage virtual-network-family.

public-ips

Verbs	Permissions	APIs Fully Covered	APIs Partially Covered
read	PUBLIC_IP_READ	ListPublicIps GetPublicIpByPrivateIpId GetPublicIpByIpAddress	None
use	PUBLIC_IP_READ PUBLIC_IP_ASSIGN_PRIVATE_IP PUBLIC_IP_UNASSIGN_PRIVATE_IP	ListPublicIps GetPublicIpByPrivateIpId GetPublicIpByIpAddress	For reserved public IPs: UpdatePublicIp, CreatePublicIp, DeletePublicIp (all of these also need use private-ips and manage public-ips).
manage	PUBLIC_IP_READ PUBLIC_IP_ASSIGN_PRIVATE_IP PUBLIC_IP_UNASSIGN_PRIVATE_IP PUBLIC_IP_UPDATE PUBLIC_IP_MOVE PUBLIC_IP_CREATE PUBLIC_IP_DELETE	ListPublicIps GetPublicIpByPrivateIpId GetPublicIpByIpAddress	For reserved public IPs: UpdatePublicIp, CreatePublicIp, DeletePublicIp (all of these also need use private-ips and manage public-ips).

network-security-group

Verbs	Permissions	APIs Fully Covered	APIs Partially Covered
inspect	NETWORK_SECURITY_GROUP_INSPECT NETWORK_SECURITY_GROUP_READ	None	AddNetworkSecurityGroupSe and UpdateNetworkSecurityGroup (both also need manage network-security-groups)
read	NETWORK_SECURITY_GROUP_INSPECT NETWORK_SECURITY_GROUP_READ NETWORK_SECURITY_GROUP_LIST_MEMBERS NETWORK_SECURITY_GROUP_LIST_SECURITY_RULES	GetNetworkSecurityGroup ListNetworkSecurityGroups	None

Verbs	Permissions	APIs Fully Covered	APIs Partially Covered
use	NETWORK_SECURITY_GROUP_INSPECT NETWORK_SECURITY_GROUP_READ NETWORK_SECURITY_GROUP_LIST_MEMBERS NETWORK_SECURITY_GROUP_LIST_SECURITY_RULES NETWORK_SECURITY_GROUP_UPDATE_MEMBERS	GetNetworkSecurityGroup ListNetworkSecurityGroups NetworkSecurityGroupSecurityRules ListNetworkSecurityGroupVnics	LaunchInstance (also need manage instances, read instance-images, use vnics, use subnets, and read app-catalog-listing) AttachVnic (also need manage instances, and use subnets) UpdateVnic (also need use vnics)

Verbs	Permissions	APIs Fully Covered	APIs Partially Covered
manage	NETWORK_SECURITY_GROUP_INSPECT NETWORK_SECURITY_GROUP_READ NETWORK_SECURITY_GROUP_LIST_MEMBERS NETWORK_SECURITY_GROUP_LIST_SECURITY_RULES NETWORK_SECURITY_GROUP_UPDATE_MEMBERS NETWORK_SECURITY_GROUP_CREATE NETWORK_SECURITY_GROUP_DELETE NETWORK_SECURITY_GROUP_MOVE NETWORK_SECURITY_GROUP_UPDATE NETWORK_SECURITY_GROUP_UPDATE_SECURITY_RULES	GetNetworkSecurityGroup ListNetworkSecurityGroups ListNetworkSecurityGroupSecurityRules ListNetworkSecurityGroupVnics UpdateNetworkSecurityGroup ChangeNetworkSecurityGroupCompartment AddNetworkSecurityGroupSecurityRules	LaunchInstance (also need manage instances, read instance-images, use vnics, use subnets, and read app-catalog-listing) AttachVnic (also need manage instances, and use subnets) UpdateVnic (also need use vnics) CreateNetworkSecurityGroup DeleteNetworkSecurityGroup (both also need manage vns) Note: Both of the above operations in this cell are totally covered with just manage virtual-network-family.

security-lists

Verbs	Permissions	APIs Fully Covered	APIs Partially Covered
inspect	SECURITY_LIST_READ	ListSecurityLists GetSecurityList	None
read	SECURITY_LIST_READ	ListSecurityLists GetSecurityList	None

Verbs	Permissions	APIs Fully Covered	APIs Partially Covered
use	SECURITY_LIST_READ	ListSecurityLists GetSecurityList	None
manage	SECURITY_LIST_READ SECURITY_LIST_UPDATE SECURITY_LIST_MOVE SECURITY_LIST_ATTACH SECURITY_LIST_DETACH SECURITY_LIST_CREATE SECURITY_LIST_DELETE	ListSecurityLists GetSecurityList UpdateSecurityList	CreateSecurityList, DeleteSecurityList (both also need manage vcms) CreateSubnet, DeleteSubnet (both also need manage vcms, manage subnets, manage route-tables, manage dhcp-options) UpdateSubnet (if changing which security lists are associated with the subnet, also need manage subnets) Note: All of the above operations in this cell are totally covered with just manage virtual-network-family.

private-ips

Verbs	Permissions	APIs Fully Covered	APIs Partially Covered
inspect	PUBLIC_IP_READ	ListPublicIps GetPublicIpByPrivateIpId GetPublicIpByIpAddress	None

Verbs	Permissions	APIs Fully Covered	APIs Partially Covered
read	PUBLIC_IP_READ	ListPublicIps GetPublicIpByPrivateIpId GetPublicIpByIpAddress	None
use	PRIVATE_IP_READ PRIVATE_IP_UNASSIGN PRIVATE_IP_UNASSIGN_PUBLIC_IP PRIVATE_IP_UPDATE PRIVATE_IP_ASSIGN PRIVATE_IP_ASSIGN_PUBLIC_IP PRIVATE_IP_CREATE PRIVATE_IP_DELETE	ListPublicIps GetPublicIpByPrivateIpId GetPublicIpByIpAddress For ephemeral public IPs: UpdatePublicIp, CreatePublicIp, DeletePublicIp	CreatePrivateIp, DeletePrivateIp (both also need use subnets and use vnics) UpdatePrivateIp (also needs use vnics) For reserved public IPs: UpdatePublicIp, CreatePublicIp, DeletePublicIp (all also need manage public-ips) Note: The above operations in this cell are totally covered with just use virtual- network- family.

Verbs	Permissions	APIs Fully Covered	APIs Partially Covered
manage	PRIVATE_IP_READ PRIVATE_IP_UNASSIGN PRIVATE_IP_UNASSIGN_PUBLIC_IP PRIVATE_IP_UPDATE PRIVATE_IP_ASSIGN PRIVATE_IP_ASSIGN_PUBLIC_IP PRIVATE_IP_CREATE PRIVATE_IP_DELETE PRIVATE_IP_ROUTE_TABLE_ATTACH PRIVATE_IP_ROUTE_TABLE_DETACH	For ephemeral public IPs: UpdatePublicIp, CreatePublicIp, DeletePublicIp	CreatePrivateIp, DeletePrivateIp (both also need use subnets and use vnics) UpdatePrivateIp (also needs use vnics) For reserved public IPs: UpdatePublicIp, CreatePublicIp, DeletePublicIp (all also need manage public-ips) Note: The above operations in this cell are totally covered with just use virtual- network- family.

dhcp-options

Verbs	Permissions	APIs Fully Covered	APIs Partially Covered
inspect	DHCP_READ	ListDhcpOptions GetDhcpOptions	None
read	DHCP_READ	ListDhcpOptions GetDhcpOptions	None
use	DHCP_READ	ListDhcpOptions GetDhcpOptions	None

Verbs	Permissions	APIs Fully Covered	APIs Partially Covered
manage	DHCP_READ DHCP_UPDATE DHCP_MOVE DHCP_ATTACH DHCP_DETACH DHCP_CREATE DHCP_DELETE	ListDhcpOptions GetDhcpOptions UpdateDhcpOptions Note: Ability to update a set of DHCP options is available only with the manage verb, not the use verb.	CreateDhcpOptions, DeleteDhcpOptions (both also need manage vcn) CreateSubnet, DeleteSubnet (also need manage vcn, manage subnets, manage route-tables, manage security-lists) UpdateSubnet (if changing which set of DHCP options is associated with the subnet, also need manage subnets) Note: All of the above operations in this cell are totally covered with just manage virtual-network-family.

vnics

Verbs	Permissions	APIs Fully Covered	APIs Partially Covered
inspect	VNIC_READ	GetVnic	CreateInstanceConfiguration (if using the CreateInstanceConfigurationFromInstanceDetail subtype. Also need read instances, inspect vnic-attachments, inspect volumes, and inspect volume-attachments.)
read	VNIC_READ	GetVnic	None
use	VNIC_READ VNIC_UNASSIGN VNIC_ASSIGN VNIC_UPDATE VNIC_ASSOCIATE_NETWORK_SECURITY_GROUP VNIC_DISASSOCIATE_NETWORK_SECURITY_GROUP VNIC_ATTACH VNIC_DETACH VNIC_CREATE VNIC_DELETE	GetVnic	LaunchInstance (also need use subnets, use network-security-groups, and manage instance-family) AttachVnic (also need manage instances, use subnets, and use network-security-groups) UpdateVnic (also need use network-security-groups) DetachVnic (also need manage instances and use subnets) CreatePrivateIp, DeletePrivateIp (both also need use subnets and use private-ips)

Verbs	Permissions	APIs Fully Covered	APIs Partially Covered
manage	VNIC_READ	GetVnic	LaunchInstance (also need use subnets, use network-security-groups, and manage instance-family)
	VNIC_UNASSIGN		
	VNIC_ASSIGN		
	VNIC_UPDATE		AttachVnic (also need manage instances, use subnets, and use network-security-groups)
	VNIC_ASSOCIATE_NETWORK_SECURITY_GROUP		UpdateVnic (also need use network-security-groups)
	VNIC_DISASSOCIATE_NETWORK_SECURITY_GROUP		
	VNIC_ATTACH		DetachVnic (also need manage instances and use subnets)
	VNIC_DETACH		
	VNIC_CREATE		CreatePrivateIp, DeletePrivateIp (both also need use subnets and use private-ips)
VNIC_DELETE			

Object Storage Permissions for Roving Edge Infrastructure

Describes the details for writing user IAM policies that control access to rules for the Object Storage service for a Roving Edge Infrastructure device.

Resource-Types

object-family

buckets

objects

objectstorage-namespaces

Details for Verb + Resource-Type Combinations

The following tables show the permissions and API operations covered by each verb. The level of access is cumulative as you go from inspect > read > use > manage.

object-family

Verbs	Permissions	APIs Fully Covered	APIs Partially Covered
inspect	BUCKET_INSPECT	HeadBucket	None
	OBJECT_INSPECT	ListBuckets	
read	BUCKET_INSPECT	HeadBucket	None
	BUCKET_READ	ListBuckets	
	NBAC_READ	GetBucket	
	OBJECTSTORAGE_NAMESPACE_READ	ListMultipartUploads	
	OBJECT_INSPECT	GetNamespace	
	OBJECT_READ	GetObject	

Verbs	Permissions	APIs Fully Covered	APIs Partially Covered
use	BUCKET_INSPECT BUCKET_READ BUCKET_UPDATE NBAC_READ OBJECTSTORAGE_NAMESPACE_READ OBJECT_INSPECT OBJECT_OVERWRITE OBJECT_READ	None	CreateBucket (also need manage buckets) PutObject (also need manage objects)
manage	BUCKET_CREATE BUCKET_DELETE BUCKET_INSPECT BUCKET_READ BUCKET_UPDATE NBAC_MANAGE NBAC_READ OBJECTSTORAGE_NAMESPACE_READ OBJECTSTORAGE_NAMESPACE_UPDATE OBJECT_CREATE OBJECT_DELETE OBJECT_INSPECT OBJECT_OVERWRITE OBJECT_READ OBJECT_RESTORE OBJECT_UPDATE_TIER OBJECT_VERSION_DELETE PAR_MANAGE RETENTION_RULE_LOCK RETENTION_RULE_MANAGE	DeleteBucket AbortMultipartUpload	CreateBucket (also need manage buckets) PutObject (also need manage objects) CommitMultipartUpload (also need use objects) CreateMultipartUpload (also need use objects) UploadPart (also need use objects) RenameObject (also need use objects) DeleteObject (also need manage objects)

buckets

Verbs	Permissions	APIs Fully Covered	APIs Partially Covered
inspect	BUCKET_INSPECT	HeadBucket ListBuckets	None

Verbs	Permissions	APIs Fully Covered	APIs Partially Covered
read	BUCKET_INSPECT	HeadBucket	None
	BUCKET_READ	ListBuckets	
		GetBucket	
		ListMultipartUploads	
use	BUCKET_INSPECT	None	CreateBucket (also need use buckets)
	BUCKET_READ		
	BUCKET_UPDATE		
manage	BUCKET_INSPECT	DeleteBucket	None
	BUCKET_READ		
	BUCKET_UPDATE		
	BUCKET_CREATE		
	BUCKET_DELETE		

objects

Verbs	Permissions	APIs Fully Covered	APIs Partially Covered
inspect	OBJECT_INSPECT	ListMultipart	None
		UploadParts	
		ListObjects	
		ListObjectVersionsHeadObject	
read	OBJECT_INSPECT OBJECT_READ	ListMultipart	None
		UploadParts	
		ListObjects	
		ListObjectVersionsHeadObject	
		GetObject	
use	OBJECT_INSPECT OBJECT_READ OBJECT_OVERWRITE	None	PutObject, CommitMultipartUpload, CreateMultipartUpload, UploadPart, RenameObject (also need manage objects)

Verbs	Permissions	APIs Fully Covered	APIs Partially Covered
manage	OBJECT_INSPECT OBJECT_READ OBJECT_OVERWRITE OBJECT_VERSION_DELETE OBJECT_CREATE OBJECT_DELETE	AbortMultipartUpload	PutObject, CommitMultipartUpload, CreateMultipartUpload, UploadPart, RenameObject (also need manage objects) DeleteObject (also need manage objects)

objectstorage-namespaces

Verbs	Permissions	APIs Fully Covered	APIs Partially Covered
read	OBJECTSTORAGE_NAMESPACE_READ	FindNamespace	None
use	OBJECTSTORAGE_NAMESPACE_READ	FindNamespace	None
manage	OBJECTSTORAGE_NAMESPACE_READ OBJECTSTORAGE_NAMESPACE_UPDATE	None	None

System Upgrade Permissions for Roving Edge Infrastructure

Describes the details for writing user IAM policies that control access to rules for the system upgrade capability of a Roving Edge Infrastructure device.

Resource-Types

systemupgrade

Details for Verb + Resource-Type Combinations

The following tables show the permissions and API operations covered by each verb. The level of access is cumulative as you go from inspect > read > use > manage.

systemupgrade

Verbs	Permissions	APIs Fully Covered	APIs Partially Covered
inspect	SYSTEM_UPGRADE_INSPECT	ListTasks	None
read	SYSTEM_UPGRADE_INSPECT SYSTEM_UPGRADE_READ	ListTasks ListSystemUpgrades GetTask	None

Verbs	Permissions	APIs Fully Covered	APIs Partially Covered
use	SYSTEM_UPGRADE_INSPECT	ListTasks	None
	SYSTEM_UPGRADE_READ	ListSystemUpgrades	
	SYSTEM_UPGRADE_UPDATE	GetTask	
manage	SYSTEM_UPGRADE_INSPECT	ListTasks	None
	SYSTEM_UPGRADE_READ	ListSystemUpgrades	
	SYSTEM_UPGRADE_UPDATE	GetTask	
	SYSTEM_UPGRADE_DELETE	NodeReboot	
		SystemUpgradesDownload	
		UpgradeNode	
		RollbackNode	
		UnlockNode	
		StartTask	
	SystemUpgradesDelete		

Managing Roving Edge Infrastructure Device Master Keys

Describes how to manage the master keys of Roving Edge Infrastructure devices.

The root access to a Roving Edge Infrastructure device is determined by its master key. When you order a device, you enter the master key passphrase. Submission of this passphrase is a prerequisite to running a variety of device tasks. Normally Oracle creates and manages the master key for you. However, you can elect the use your own master key instead of the one provided by Oracle. You can also destroy the master key, rendering the device useless until recovered with another master key.

You can perform the following master key-based tasks:

- [Using Your Own Master Key](#)
- [Shredding Your Device's Master Key](#)
- [Recovering Your Device After Shredding its Master Key](#)

Using Your Own Master Key with Roving Edge Infrastructure Devices

Describes how to set up a user-provided KMS-based master key to manage secret information on Roving Edge Infrastructure devices.

By default, Oracle manages secret information on your Roving Edge Infrastructure devices, such as the superuser passphrase and unlock password, using a KMS-based master key. Oracle also uses a hardware security module to further protect this data. However, as an alternative to relying on Oracle's master key to manage this secret data, you can provide your own KMS-based master key from your own OCI tenancy.

Note:

You can only provide your own master key when creating the node resource. You can't edit an existing node resource to use your own master key the resource was originally created using an Oracle-provided master key.

Writing the Master Key Policy

To use your own master key, you must first write a policy that authorizes this capability using one of the following methods:

- **Using the Oracle Cloud Infrastructure Console:**

Create the following policy:

```
allow service rover to use keys in compartment ID compartment-id where
target.key.id = master-key-id
```

where *master-key-id* is the master key OCID in the customer tenancy that is used to encrypt customer secret information like the superuser password and unlock passphrase. For example:

```
allow service rover to use keys in compartment ID compartment-id where
target.key.id = 'ocid1.key.region1..exampleuniqueID'
```

- **Using the CLI:**

Enter the following command:

```
oci rover policy create-master-key-policy --master-key-id master_key_ocid
--policy-compartment-id policy_compartment_ocid --policy-name policy_name
```

For example:

```
oci rover policy create-master-key-policy --master-key-id
'ocid1.key.region1..exampleuniqueID' --policy-compartment-id
'ocid1.tenancy.region1..exampleuniqueID' --policy-name 'test-policy'
```

Selecting the Vault and Master Key

After you write the policy, select your vault and master key and the compartments in which they reside using one of the following methods:

- **Using the Oracle Cloud Infrastructure Console:**

When you create a Roving Edge Infrastructure node resource using the Create dialog box within the Oracle Cloud Infrastructure Console, the **Encryption Key** section appears. Here you can select one of the following options:

- **Encrypt using Oracle-managed keys:** Choose to have key encryption managed by the Oracle Cloud Infrastructure service. No further action is required.
- **Encrypt using customer managed keys:** Choose to provide your own encryption key.

If you choose to provide your own key, the Encryption Key section displays the additional fields:

- **Vault Compartment:** Select the compartment containing the vault you want from the list.
 - **Vault:** Select one of the vaults from the list contained within the vault compartment you previously chose.
 - **Master Encryption Key Compartment:** Select the compartment containing the master encryption key you want from the list.
 - **Master Encryption Key:** Select one of the master encryption keys from the list within the master encryption key value you previously chose.
- **Using the CLI:**

Include the *master-key-id* option when you create the Roving Edge Infrastructure node resource. For example:

```
oci rover node create --display-name display_name --compartment-
id compartment_ocid --shape shape --master-key-id master_key_ocid --
policy-compartment-id policy_compartment_ocid --policy-name policy_name
```

For example:

```
oci rover node create --display-name 'test1' --compartment-id
'ocidl.tenancy.region1..exampleuniqueID' --shape RED_GPU_1_RX1_40 --
master-key-id 'ocidl.key.region1..exampleuniqueID' --policy-compartment-id
'ocidl.tenancy.region1..exampleuniqueID' --policy-name 'test-policy'
```

After setting up the master key policy, RCS is invoked to validate access to the vault as part of creating the node.

Shredding the Master Key for Roving Edge Infrastructure Devices

Describes how to destroy the master key on Roving Edge Infrastructure devices.

You can destroy or "shred" the master key of your Roving Edge Infrastructure devices. Run this command if you believe the device's has been compromised or is unsafe and is likely to be compromised.

Caution:

Shredding the master key permanently deletes the key and shuts down the device.

Your device must be running and connected to your controlling host running terminal emulation software such as PuTTY to shred its master key. See [Set Up Terminal Emulation](#) on page 33.

Using terminal emulation, select the **Shred Key** menu option. Confirm your choice to shred your master key and enter your existing Unlock passphrase when prompted.

When the master key is shredded, the device is no longer operable. When the device is restarted, the following message is displayed:

```
The system can not proceed with boot due to missing Master Security Key.
```

You must reconfigure the master security key before the device will restart fully. See [Recovering Your Roving Edge Infrastructure Device After Shredding the Master Key](#) on page 122 for more information.

Recovering Your Roving Edge Infrastructure Device After Shredding the Master Key

Describes how to recover a device on which you have shredded the master key.

If you have rendered your Roving Edge Infrastructure device inoperable because you shredded the master key as described in [Shredding the Master Key for Roving Edge Infrastructure Devices](#) on page 122, you can recover the device and return it to service by recovering the key.

Your device must be running and connected to your controlling host running terminal emulation software such as PuTTY to unlock the device. See [Set Up Terminal Emulation](#) on page 33.

Using terminal emulation, select the **Recover Key** menu option and follow the prompts to enter a new passphrase. This new passphrases replaces the passphrase you originally entered when you created the node in Oracle Cloud Infrastructure.

Getting Started

Describes how to get started setting up and running your Roving Edge Infrastructure service and Roving Edge Infrastructure devices.

This Getting Started section leads you through the steps of preparing your Oracle Cloud Infrastructure tenancy to use the Roving Edge Infrastructure service. After you have accessed the Roving Edge Infrastructure service, request the number of type of Roving Edge Infrastructure devices you need to creating the appropriate node resource type:

- Single Roving Edge Infrastructure device: Roving Edge Device Node
- Single Ultra device: Ultra Node

Create these resources using the Oracle Cloud Infrastructure Console, Command Line Interface (CLI), or API. As you create the resource, you specify the content you want pre-loaded or *provisioned* on each device at the time it arrives.

Request and configure your REDs using the Roving Edge Infrastructure service's node feature within the Oracle Cloud Infrastructure Console. After the devices are delivered and integrated into your local network, operate the REDs using the Device Console.

Proceed through these sections to learn the basics of setting up your Roving Edge Infrastructure environment.

- [Policies for Managing Roving Edge Infrastructure](#) on page 62
- [Using Your Own Master Key](#)
- [Requesting Devices](#) on page 21
- [Administering Devices](#) on page 37
- [Creating and Launching Instances](#) on page 123
- [Managing Files Using Object Storage](#) on page 125
- [Syncing Your Data](#) on page 127
- [Preparing Devices for Return](#) on page 268

Creating and Launching Instances

Describes how to create and launch compute instances on your Roving Edge Infrastructure devices.

Having completed administrating your Roving Edge Infrastructure devices, you can now start running tasks using the on-device services and the data provisioned to your devices. Start by creating and launching a compute instance.

1. Open the navigation menu and select **Compute > Instances**. The **Instances** page appears. All instances are listed in tabular form.
2. Click **Create Instance**. The **Create Compute Instance** dialog box appears.
3. Complete the following:
 - **Name**: Enter a name for the instance.
 - **Image or operating system**: Click **Change Image**. The **Browse All Images** dialog box appears. Select one of the following image options:
 - **Platform Images** tab: Check the pre-built image you want for the instance from the list and click **Select Image**.
 - **Custom Images** tab: Click **Select Image**. The image you selected is displayed in the **Image or operating system** box.
 - **Shape**: Click **Change Shape**. The **Browse All Shapes** dialog box appears. Select a **Standard** or **Specialty** shape type, then select one of the corresponding shapes that appear. Click **Select Shape**. The shape you selected is displayed in the **Shape** box.
 - **Select a virtual cloud network**: Select a virtual cloud network from the list.
 - **Select a subnet**: Select a subnet associated with the virtual cloud network from the list.
 - **IP address**: Select an IP address option:
 - **Assign a public IP address** (if selected, an IP address from the external CIDR is used)
 - **Do not assign a public IP address**
 - **Specify a custom boot volume size**: Check if you do not want to use the default boot volume size. Enter the size in the **Boot volume size** box.
 - **SSH key**: Select an SSH key option:
 - **Choose SSH key file**: Click **browse to a location** and navigate to your SSH key file where you can select it for upload. You can also drag the file into the **SSH keys** box.
 - **Paste SSH keys**: Copy and paste the SSH key directly into the **SSH keys** box.

Note:

If the original image had the user keys on it, the new keys might not be added to the resulting instance, depending on the image specifics.

4. Click **Create**. Upon creation of the instance, the new instance's **Details** page opens automatically.
5. Review the contents of the instance's **Details** page. It contains information such as its current state (indicated by the image in the upper left corner), IP addresses used, the image used, shape settings. You can view the boot volume, and attached VNICs by clicking their respective links in the lower left corner. Creation of the instance can take several minutes. During this time, the state is **Provisioning**. When the creation is complete, the state changes to **Running**. This state indicates that the instance is now launched.

See [Instances for Roving Edge Infrastructure Devices](#) on page 189 for more information.

Creating a Block Volume

After you have created and launched your initial instance, create a block volume that you can attach to the instance.

1. Open the navigation menu and select **Block Storage > Block Volumes**. The **Block Volumes** page appears. All block volumes are listed in tabular form.
2. Select a **State** from the list to limit the block volumes displayed to that state.
3. Click **Create Block Volume**. The **Create Block Volume** dialog box appears.
4. Complete the following:
 - **Name**: A user-friendly name or description.
 - **Size**: Must be between **50 GB** and **6 TB**. You can choose in 1 GB increments within this range. The default is 300 GB. If you choose a size outside of your service limit, you might be prompted to request an increase.
5. Check **View detail page after this block volume is created** to display the block volume's **Details** page after you create it.
6. Click **Create Block Volume**. The volume is ready to attach after its icon no longer lists it as **Provisioning** in the **Volume** list.

Attaching the Block Volume

After you have created your block volume, attach it to the instance you previously created and launched.

1. Open the navigation menu and select **Compute > Instances**. The **Instances** page appears. All instances are listed in tabular form.
2. Select a **State** from the list to limit the instances displayed to that state.
3. Click the instance to which you want to attach a block volume under **Instances**.
4. Click **Attached Block Volumes** in the lower left corner. The **Attached Block Volumes** page appears. All attached block volumes are listed in tabular form.
5. Click **Attach Block Volume**. The **Attach Block Volume** dialog box appears. By default, the attached block volume type is **Paravirtualized**.
6. Choose the volume selection option:
 - **Select Volume**: Select the volume from the **Block Volume** list.
 - **Enter Volume OCID**: Enter the OCID into the **Block Volume OCID** box.
7. **Select a Device Path**: Choose one from the list of device paths. For example:
`/dev/oracleoci/oraclevdb`
8. Select the access type:
 - **Read/Write**
 - **Read/Write - Shareable**
 - **Read-only**
9. Click **Attach**.

The block volume appears in the **Attached Block Volume** page.

What's Next?

After you have completed the tasks associated with creating and launching instances on your REDs, continue on to [Managing Files Using Object Storage](#) on page 125.

Managing Files Using Object Storage

Describes how to manage files using the on-device Object Storage service on your Roving Edge Infrastructure devices.

Now you are ready to work with your object storage resources and content. Each Roving Edge Infrastructure device contains a single default compartment in which you can create and manage buckets and the objects (files) they contain.

Creating a Bucket

Create a bucket within object storage where you can store and retrieve files.

1. Open the navigation menu and select **Storage > Object Storage & Archive Storage**. The **Buckets** page appears. All buckets are listed in tabular form.
2. Click **Create Bucket**. The **Create Bucket** dialog box appears.
3. Enter a name in the **Bucket Name** box. The system generates a default bucket name that reflects the current year, month, day, and time, for example **bucket-20190306-1359**. If you change this default to any other bucket name, use letters, numbers, dashes, underscores, and periods. Avoid entering confidential information.
4. Select **Enable Object Versioning** if you want to apply versioning to all objects that you upload. See [Object Versioning](#).
5. Click **Create**.

Upload Objects to Your Bucket

The bucket you just created now appears in the list of buckets in the Buckets page. Access the bucket and upload objects (files) into it.

1. Open the navigation menu and select **Storage > Object Storage & Archive Storage**. The **Buckets** page appears. All buckets are listed in tabular form.
2. Click the bucket to which you want to upload objects. The bucket's **Details** page appears. All objects are listed in tabular form.
3. Click **Upload**. The **Upload Objects** dialog box appears.

Note:

Checking objects in the **Objects** list and then clicking **Upload** does not automatically upload those files. Select files you want to upload in the **Upload Objects** dialog box.

4. Specify an **Object Name Prefix** value. This prefix value is prepended to each one of the files you upload. You can specify the following prefix strings:
 - Prefix strings without a delimiter for matching purposes to perform allowed bulk operations
5. Select the group of objects you want to upload using any combination of the following methods:
 - Drag and drop one or more files from your computer.
 - Click the **select files** link and select the files you want to upload.

The files you select to upload are displayed in a list. If you decide that you do not want to upload a particular file, click the **X** to the right of the file name.

If the files you select to upload are already stored in the bucket or folder with the same name, the Console displays messages warning you of an overwrite.

6. Click **Upload**. The selected objects are uploaded and displayed in the list of objects in the bucket.
7. Click **Close** to return to the bucket's **Details** page.

Viewing Object Details

After you have uploaded an object into your object storage bucket, you can view its details.

1. Open the navigation menu and select **Storage > Object Storage & Archive Storage**. The **Buckets** page appears. All buckets are listed in tabular form.
2. Click the bucket whose details you want to get. The bucket's **Details** page appears. All objects are listed in tabular form.
3. Select the Actions menu (⋮) for the object whose details you want to get and click **View Object Details**. The object's **Details** page appears. If object has versioning applied to it, the command is renamed View Object Versioning Details. The ObjectAll versions of the object are

Downloading Objects from Your Bucket

You can download objects in a bucket to your local computer.

1. Open the navigation menu and select **Storage > Object Storage & Archive Storage**. The **Buckets** page appears. All buckets are listed in tabular form.
2. Click the bucket whose details you want to get. The bucket's **Details** page appears. All objects are listed in tabular form.
3. Select the Actions menu (⋮) for the object whose details you want to get and click **View Object Details**. The **Object Details** dialog box appears.
4. Click **Download**.

Alternately, you can select the Actions menu (⋮) for the object in the Objects page and click **Download**. The object is downloaded to your local computer in the default download location.

Deleting Objects

You can delete an object that you have uploaded to your object storage bucket.

1. Open the navigation menu and select **Storage > Object Storage & Archive Storage**. The **Buckets** page appears. All buckets are listed in tabular form.
2. Click the bucket containing the object you want to delete. The bucket's **Details** page appears. All objects are listed in tabular form.
3. Check each object that you want to delete.
4. Click **Delete Objects**. To delete a single object, select the Actions menu (⋮) for that object in the Buckets page and click **Delete**.
5. Confirm the deletion when prompted.

Deleting Buckets

Finally, rounding out our review of object storage tasks, you can delete the bucket you originally created.

1. Open the navigation menu and select **Storage > Object Storage & Archive Storage**. The **Buckets** page appears. All buckets are listed in tabular form.
2. Click the bucket that you want to delete. The bucket's **Details** page appears.
3. Click **Delete**.
4. Confirm the deletion when prompted.

What's Next?

After you have completed the tasks associated with managing files using object storage, continue on to [Syncing Your Data](#) on page 127.

Syncing Your Data

Sync the content and system data between your Roving Edge Infrastructure devices and Oracle Cloud Infrastructure buckets in your tenancy.

Although Roving Edge Infrastructure devices are designed to operate connected, semi-connected and disconnected from the cloud for days or weeks at a time, syncing the data between your Roving Edge Infrastructure devices and your Oracle Cloud Infrastructure tenancy is an important task you must do regularly.

You can perform syncing in the following ways:

- Roving Edge Infrastructure device bucket-to-Oracle Cloud Infrastructure bucket: Upload data to your Oracle Cloud Infrastructure object storage buckets for processing and long-term storage, freeing space on the devices.
- Oracle Cloud Infrastructure bucket-to-Roving Edge Infrastructure device bucket: Download data residing in the object storage buckets in your Oracle Cloud Infrastructure tenancy to the devices. Also update system files for the device and its browser-based user interface.

Note:

You cannot set up a bi-directional sync using two tasks and the same object storage buckets used by Oracle Cloud Infrastructure and the Roving Edge Infrastructure devices.

See [Data Sync Tasks](#) for more information.

What's Next?

You have completed the Getting Started section. The remainder of this documentation describes the various features and services available to using the Roving Edge Infrastructure services and the Roving Edge Infrastructure devices.

Roving Edge Infrastructure Device Nodes

Manage your Roving Edge Infrastructure device nodes in Oracle Cloud Infrastructure, including creating, updating, and deleting them.

A Roving Edge Infrastructure node resource in the Oracle Cloud Infrastructure Cloud represents a single device node provisioned with workloads (object storage buckets and compute instances) sourced from your Oracle Cloud Infrastructure tenancy. When you create a device node request in Oracle Cloud Infrastructure Cloud, you are requesting a device be sent to you provisioned with the data you specify.

Request a Roving Edge Infrastructure device node in the Oracle Cloud Infrastructure Cloud by accessing the Roving Edge Infrastructure service and creating a node resource. A device node resource includes the following required or optional components:

- User-defined name
- Predefined shape
- Compartment location in your Oracle Cloud Infrastructure tenancy
- Password
- Passphrase
- Shipping information (delivery to customer site or pickup from Oracle facility)
- Certificate
- Tagging
- One or more selected workloads, consisting of object storage, and compute instances residing on your Oracle Cloud Infrastructure tenancy. That content is preloaded onto the node and then made available to you by the delivery method you specify.

Note:

Ordering Oracle Roving Edge Infrastructure devices requires important terms and conditions to be understood and acknowledged before taking

possession. Please confirm that these terms and conditions have been included as part of your Oracle Cloud agreement. Once Oracle validates your request, your Roving Edge Infrastructure are provisioned and available for your possession.

You can perform the following Roving Edge Infrastructure device node management tasks:

- [Creating a Device Node](#)
- [Attaching a Workload to a Device Node](#)
- [Listing Workloads for Device Nodes](#)
- [Deleting a Workload from a Device Node](#)
- [Submitting a Device Node Request](#)
- [Listing Device Nodes](#)
- [Listing Device Node Shapes](#)
- [Getting a Device Node's Details](#)
- [Editing a Device Node](#)
- [Moving a Device Node Between Compartments](#)
- [Deleting a Device Node](#)

Creating a Roving Edge Infrastructure Device Node

Create a Roving Edge Infrastructure device node in Oracle Cloud Infrastructure.

These instructions create the device node. After the device node is created, you can attach an image workload and an Object Storage bucket workload to it before you submit it for approval (provisioning). Or you can attach workloads after your device node is provisioned. See [Attaching a Workload to a Roving Edge Infrastructure Device Node](#) on page 130.

Note:

Roving Edge Infrastructure device node orders can only be shipped to specific countries depending on where the order is placed. Contact your Oracle account representative for more information. See [Country Support](#) for more information.

For information about Roving Edge models and shapes, see [Roving Edge Infrastructure Device Specifications](#) on page 10.

Using the OCI Console

1. Open the navigation menu and click **Hybrid**. Under **Roving Edge Infrastructure**, click **Nodes**. The **Nodes** page appears.
2. Click **Create Node**. The **Create Node** dialog box appears. Complete the following fields under **Basic information**:
 - **Name**: Enter a name for the device node.
 - **Create in compartment**: Select the compartment in which the device node you create resides.
 - **Shape**: Select a shape based on the Roving Edge Device model that you're requesting. For shape names and specifications, see [Roving Edge Infrastructure Device Specifications](#) on page 10.
 - **Enclosure Type**: Select one of the following options:
 - **Ruggedized**: If selected, you receive a ruggedized case. See [Ruggedizing Roving Edge Infrastructure Devices](#) on page 53.
 - **No Case**: Select this option if you don't want a case.
3. Enter a **Super user password** and **Confirm the super user password**.

The password is for the super user account on the node.

Password requirements:

- Length: 8 - 12 characters
 - Must include at least one: lowercase, numeric, and special character: ! # \$ % & () * + - . / : ; @ = < > [] ^ _ | ~ \ { }
4. Enter an **Unlock passphrase** and **Confirm unlock passphrase**.
- The passphrase is used to decrypt data at rest on the node.
- passphrase requirements:
- Length: 8 - 12 characters
 - Must include at least one: lowercase, numeric, and special character: ! # \$ % & () * + - . / : ; @ = < > [] ^ _ | ~ \ { }
5. For **Shipping Information**. Choose one of the options:
- **Shipped by Oracle**: Complete the following shipping information:
 - **Point of contact**
 - **Care of**
 - **Recipient phone**
 - **Recipient email**
 - **Country**
 - **Address line 1**
 - **Address line 2 (optional)**
 - **City/Locality**
 - **State/Province/Region**
 - **Zip/Postal code**
 - **Country**: Roving Edge Infrastructure device node orders can only be shipped to specific countries depending on where the order is placed. Contact your Oracle account representative for more information.
 - **Pickup from Oracle**
6. (optional) Expand **Certificate options**: Click to display and complete the following certificate options:
- **Common Name**: Enter a name for the certificate.
 - **Issuer Certificate Authority in <compartment>**: Select a certificate authority to be used for generating and renewing certificates for the device node. Click **Change Compartment** to select a certificate authority in another compartment.
 - **Certificate Validity End Date**: Enter the date and time on which the certificate is no longer valid.
 - **Signature Algorithm**: Select a signature algorithm from the list.
 - **Key Algorithm**: Select a key algorithm from the list.
 - **Certificate Compartment**: Select the compartment where the certificate resides.
7. (optional) **Show Tagging options**: Click to display the **Tagging** option. If you have permissions to create a resource, then you also have permissions to apply free-form tags to that resource. To apply a defined tag, you must have permissions to use the tag namespace.

Note:

If you are not sure about whether to apply tags, then skip this option (you can apply tags later) or ask your administrator.

Complete the following:

- **Tag Namespace**
- **Tag Key**
- **Value**

Click **+Another Tag** to add another tag. Click **X** to remove the associated tag.

See for descriptions of these fields.

8. Click **Create Node**.

The device node you created is added to the list of nodes.

After creating the node, perform one of the following procedures:

- Submit a device node request. See [Submitting a Roving Edge Infrastructure Device Node Request](#) on page 133.
- Attach an image workload and an Object Storage bucket workload. See [Attaching a Workload to a Roving Edge Infrastructure Device Node](#) on page 130.

Using the CLI

Use the `oci rover node create` command and required parameters to create a Roving Edge Infrastructure device node in Oracle Cloud Infrastructure:

```
oci rover node create --compartment-id compartment_ocid --display-name display-name --shape shape_name [OPTIONS]
```

To determine your Roving Edge Infrastructure device compartment OCID, see [Compartments](#).

For *shape_name*, specify one of the following shape values based on the Roving Edge Ultra device model:

- Roving Edge Device: RED_GPU_1_RX1_40
- Roving Edge Device – Compute: RED_2_56
- Roving Edge Device – GPU: RED_2_56_GPU
- Roving Edge Device – Storage: RED2_56_STG

For a complete list of parameters and values for CLI commands, see the [CLI Command Reference](#).

After creating the node, perform one of the following procedures:

- Submit a device node request. See [Submitting a Roving Edge Infrastructure Device Node Request](#) on page 133.
- Attach an image workload and an Object Storage bucket workload. See [Attaching a Workload to a Roving Edge Infrastructure Device Node](#) on page 130.

Using the API

Run the [CreateRoverNode](#) operation to create a Roving Edge Infrastructure device node in Oracle Cloud Infrastructure.

Attaching a Workload to a Roving Edge Infrastructure Device Node

Attach a workload to a Roving Edge Infrastructure device node in Oracle Cloud Infrastructure.

Note:

Attach workloads *after* creating the node.

Workloads determine the Oracle Cloud Infrastructure-based content that's included when a Roving Edge Infrastructure device node is provisioned. When you request a Roving Edge Infrastructure device node for provisioning, you can attach the available workloads associated with that Roving Edge Infrastructure device node for inclusion. When your device arrives, it contains the content from the workloads you specified at the time of provisioning. Or, you can attach workloads after your device node is provisioned.

Note:

The maximum size of an object you can use with Roving Edge Infrastructure devices is 5 TB. Any objects in your object store workload or any custom images greater than 5 TB in size are not be provisioned onto your Roving Edge Infrastructure device.

Workloads are managed as a resource within the Roving Edge Infrastructure device node, and you can attach, edit, and delete them. Each node's Details page contains a link for viewing the associated workloads. The workloads are displayed in tabular form, and you can view the details of each workload, and perform tasks on them.

When you attach a workload to your Roving Edge Infrastructure device node, you specify the Oracle Cloud Infrastructure compartment and object storage bucket in which the content you want resides within your tenancy. You can also specify filters that ensure only the files you want are included.

Using the OCI Console

1. Open the navigation menu and click **Hybrid**. Under **Roving Edge Infrastructure**, click **Nodes**. The **Nodes** page appears.
2. Select the **Compartment** from the list under **List scope**. All device nodes in that compartment are listed in tabular form.
3. Select a **State** from the list under **Tag filters** to limit the device nodes displayed to that state.
4. Click the link for the node for which you are attaching the workload. The node's **Details** page appears.
5. Click **Workloads** under **Resources**. A list of workloads appears.
6. Click **Attach workload** at the top of the workloads list. The **Attach workload** dialog box appears.
7. Provide the following information:
 - **Type**: Select one of the following options:
 - **Bucket**: Complete the following:
 - **Bucket in <compartment>**: Enter the name of the bucket where the files for the selected workload reside. The bucket name is what appears under the **Name** column in the **Workload** list.
 - **Prefix**: Enter a string to use for matching against the start of object names in a list query.
 - **Range Start**: Enter a value to which object names returned by a list query must be greater or equal.
 - **Range End**: Enter a value to which object names returned by a list query must be less.
 - **Image**: Complete the following:
 - **VM Image in <compartment>**: Select one of the VM images available in the compartment. Click **Change Compartment** to select a different compartment.
8. Click **Attach workload**.

The workload you attached appears in the **Workload** list of the device node.

Using the CLI

Use the `oci rover node add-workload` command and required parameters to attach a workload to a Roving Edge Infrastructure device node in Oracle Cloud Infrastructure:

```
oci rover node add-workload --compartment-id compartment_ocid --node-id node_ocid --type "bucket" [OPTIONS]
```

To determine your Roving Edge Infrastructure device compartment OCID, see [Compartments](#).

For a complete list of parameters and values for CLI commands, see the [CLI Command Reference](#).

Using the API

Run the `RoverWorkload` definition with the `CreateRoverNode` endpoint to attach a workload to a Roving Edge Infrastructure device node in Oracle Cloud Infrastructure.

```
RoverWorkload:
  description: Rover workload
  type: object
  required:
  - id
  - compartmentId
  - workloadType
  properties:
    name:
      description: Name of the Rover Workload
      type: string
```

```

    compartmentId:
      description: The OCID of the compartment containing the workload.
      type: string
    id:
      description: The Unique Oracle ID (OCID) that is immutable on
creation.
      type: string
    size:
      description: Size of the workload.
      type: string
    objectCount:
      description: Number of objects in a workload.
      type: string
    prefix:
      description: Prefix to filter objects in case it is a bucket.
      type: string
    rangeStart:
      description: Start of the range in a bucket.
      type: string
    rangeEnd:
      description: End of the range in a bucket.
      type: string
    workloadType:
      description: The type of workload
      type: string

```

Listing Workloads for a Roving Edge Infrastructure Device Node

List the workloads attached to a Roving Edge Infrastructure node in Oracle Cloud Infrastructure.

Using the OCI Console

1. Open the navigation menu and click **Hybrid**. Under **Roving Edge Infrastructure**, click **Nodes**. The **Nodes** page appears.
2. Select the **Compartment** from the list under **List scope**. All device nodes in that compartment are listed in tabular form.
3. Select a **State** from the list under **Tag filters** to limit the device nodes displayed to that state.
4. Click the device node whose workloads you want to list. The device node's **Details** page appears.
5. Click **Workloads** under **Resources**.

All workloads attached to the device node are listed in tabular form.

Using the CLI

Use the `oci rover node list-workload` command and required parameters to get a list of workloads attached to a to attach a workload to a Roving Edge Infrastructure device node in Oracle Cloud Infrastructure device node in Oracle Cloud Infrastructure:

```
oci rover node list-workload --node-id node_ocid [OPTIONS]
```

For a complete list of parameters and values for CLI commands, see the [CLI Command Reference](#).

Using the API

Run the `nodeWorkloads` attribute under [CreateRoverNodeDetails](#) to get a list of workloads attached to a to attach a workload to a Roving Edge Infrastructure device node in Oracle Cloud Infrastructure device node in Oracle Cloud Infrastructure.

Deleting a Workloads from a Roving Edge Infrastructure Device Node

Delete a workload attached from a Roving Edge Infrastructure device node in Oracle Cloud Infrastructure.

Using the OCI Console

1. Open the navigation menu and click **Hybrid**. Under **Roving Edge Infrastructure**, click **Nodes**. The **Nodes** page appears.
2. Select the **Compartment** from the list under **List scope**. All device nodes in that compartment are listed in tabular form.
3. Select a **State** from the list under **Tag filters** to limit the device nodes displayed to that state.
4. Click the link for the device node whose workload you want to delete. The device node's **Details** page appears.
5. Click **Workloads** under **Resources**. All workloads are listed in tabular form.
6. Click the Actions menu (⋮) for the workload you want to delete and select **Delete**.
7. Confirm the deletion.

The workload you deleted is removed from the list of workloads.

Using the CLI

Use the `oci rover node delete-workload` command and required parameters to delete a workload attached from a Roving Edge Infrastructure device node in Oracle Cloud Infrastructure:

```
oci rover node delete-workload --node-id node_ocid [OPTIONS]
```

For a complete list of parameters and values for CLI commands, see the [CLI Command Reference](#).

Using the API

This task can't be performed using the API.

Submitting a Roving Edge Infrastructure Device Node Request

Submit a request for a Roving Edge Infrastructure device node in Oracle Cloud Infrastructure.

Validation of the workloads associated with the submission takes approximately 10 minutes. During this time any attempt to access the node request can result in a 400 Bad Request error.

Important:

You cannot submit an Roving Edge Device node for request unless you have attached at least one object workload and one image workload.

Using the OCI Console

1. Open the navigation menu and click **Hybrid**. Under **Roving Edge Infrastructure**, click **Nodes**. The **Nodes** page appears.
2. Select the **Compartment** from the list under **List scope**. All device nodes in that compartment are listed in tabular form.
3. Select a **State** from the list under **Tag filters** to limit the device nodes displayed to that state.
4. Click the device node you are requesting being provisioned. The device node's **Details** page appears.
5. Click **Submit for approval**.

Using the CLI

Use the `oci rover node request-approval` command and required parameters to submit a request for a Roving Edge Infrastructure device node in Oracle Cloud Infrastructure:

```
oci rover node request-approval --node-id node_ocid [OPTIONS]
```

For a complete list of parameters and values for CLI commands, see the [CLI Command Reference](#).

Using the API

This task can't be performed using the API.

Listing Roving Edge Infrastructure Device Nodes

List the Roving Edge Infrastructure device nodes in Oracle Cloud Infrastructure.

Using the OCI Console

1. Open the navigation menu and click **Hybrid**. Under **Roving Edge Infrastructure**, click **Nodes**. The **Nodes** page appears.
2. Select the **Compartment** from the list under **List scope**. All device nodes in that compartment are listed in tabular form.
3. Select a **State** from the list under **Tag filters** to limit the device nodes displayed to that state.

All types of node are listed in tabular form. You can identify a node type by its shape:

- **RED.GPU.1.RX1.40**: Roving Edge Infrastructure device node
- **ULTRA.USB.1.RX2.12**: Roving Edge Ultra node

Using the CLI

Use the following command and required parameters to list the shapes for a Roving Edge Infrastructure device node in Oracle Cloud Infrastructure:

```
oci rover node list --compartment-id compartment_ocid [OPTIONS]
```

To determine your Roving Edge Infrastructure device compartment OCID, see [Compartments](#).

For a complete list of parameters and values for CLI commands, see the [CLI Command Reference](#).

Using the API

Run the [ListRoverNodes](#) operation to list the Roving Edge Infrastructure device nodes in Oracle Cloud Infrastructure.

Listing Roving Edge Infrastructure Device Node Shapes

List the shapes for a Roving Edge Infrastructure device node in Oracle Cloud Infrastructure.

Using the OCI Console

This task can't be performed using the OCI Console.

Using the CLI

Use the `oci rover node list` command and required parameters to list the shapes for a Roving Edge Infrastructure device node in Oracle Cloud Infrastructure:

```
oci rover shape list --compartment-id compartment_ocid [OPTIONS]
```

To determine your Roving Edge Infrastructure device compartment OCID, see [Compartments](#).

For a complete list of parameters and values for CLI commands, see the [CLI Command Reference](#).

Using the API

This task can't be performed using the API.

Getting a Roving Edge Infrastructure Device Node's Details

Get the details of a Roving Edge device node in Oracle Cloud Infrastructure.

Using the OCI Console

1. Open the navigation menu and click **Hybrid**. Under **Roving Edge Infrastructure**, click **Nodes**. The **Nodes** page appears.
2. Select the **Compartment** from the list under **List scope**. All device nodes in that compartment are listed in tabular form.
3. Select a **State** from the list under **Tag filters** to limit the device nodes displayed to that state.
4. Click the link for the device node whose details you want to get.

The device node's **Details** page appears.

Using the CLI

Use the `oci rover node show` command and required parameters to get the details of a Roving Edge device node in Oracle Cloud Infrastructure:

```
oci rover node show --node-id node_ocid [OPTIONS]
```

For a complete list of parameters and values for CLI commands, see the [CLI Command Reference](#).

Using the API

Run the `GetRoverNode` operation to display the details of a node.

Editing a Roving Edge Infrastructure Device Node

Edit a Roving Edge Infrastructure device node in Oracle Cloud Infrastructure.

You cannot edit a Roving Edge Infrastructure device node if you have already submitted it for approval.

Using the OCI Console

1. Open the navigation menu and click **Hybrid**. Under **Roving Edge Infrastructure**, click **Nodes**. The **Nodes** page appears.
2. Select the **Compartment** from the list under **List scope**. All device nodes in that compartment are listed in tabular form.
3. Select a **State** from the list under **Tag filters** to limit the device nodes displayed to that state.
4. Click the device node that you want to edit. The device node's **Details** page appears.
5. Click **Edit**. The **Edit Node** dialog box appears.
6. Make your edits. See [Creating a Device Node](#) for descriptions of the settings.
7. Click **Save changes**.

Using the CLI

Use the `oci rover node update` command and required parameters to edit a Roving Edge Infrastructure device node in Oracle Cloud Infrastructure:

```
oci rover node update --display-name display-name --node-id node_ocid [OPTIONS]
```

For a complete list of parameters and values for CLI commands, see the [CLI Command Reference](#).

Using the API

Run the `UpdateRoverNode` operation to edit a Roving Edge Infrastructure device node in Oracle Cloud Infrastructure.

Moving a Roving Edge Infrastructure Device Node Between Compartments

Move a Roving Edge Infrastructure device node between compartments in Oracle Cloud Infrastructure.

Using the OCI Console

1. Open the navigation menu and click **Hybrid**. Under **Roving Edge Infrastructure**, click **Nodes**. The **Nodes** page appears.
2. Select the **Compartment** from the list under **List scope**. All device nodes in that compartment are listed in tabular form.
3. Select a **State** from the list under **Tag filters** to limit the device nodes displayed to that state.
4. Click the device node you want to move to a different compartment. The device node's **Details** page appears.
5. Click **Move resource** under the **More actions** menu. The **Move resource** dialog box appears.
6. Select the compartment to which you want to move your device node from the **Destination Compartment** list.
7. Click **Move resource**.

The device node now appears in the nodes list within the compartment where you moved it.

Using the CLI

Use the `oci rover node change-compartment` command and required parameters to move a Roving Edge Infrastructure device node between compartments in Oracle Cloud Infrastructure:

```
oci rover node change-compartment --compartment-id compartment_ocid --node-id node_ocid [OPTIONS]
```

To determine your Roving Edge Infrastructure device compartment OCID, see [Compartments](#).

compartment_ocid is the destination compartment.

For a complete list of parameters and values for CLI commands, see the [CLI Command Reference](#).

Using the API

Run the [ChangeRoverNodeCompartment](#) operation to move a Roving Edge Infrastructure device node between compartments in Oracle Cloud Infrastructure.

Deleting a Roving Edge Infrastructure Device Node

Delete a Roving Edge Infrastructure device node in Oracle Cloud Infrastructure.

Using the OCI Console

1. Open the navigation menu and click **Hybrid**. Under **Roving Edge Infrastructure**, click **Nodes**. The **Nodes** page appears.
2. Select the **Compartment** from the list under **List scope**. All device nodes in that compartment are listed in tabular form.
3. Select a **State** from the list under **Tag filters** to limit the device nodes displayed to that state.
4. Click the device node you want to delete. The device node's **Details** page appears.
5. Click **Delete**.
6. Confirm the deletion when prompted.

The device node you deleted no longer appears in the nodes list.

Using the CLI

Use the `oci rover node delete` command and required parameters to delete a Roving Edge Infrastructure device node in Oracle Cloud Infrastructure:

```
oci rover node delete --node-id node_ocid [OPTIONS]
```

For a complete list of parameters and values for CLI commands, see the [CLI Command Reference](#).

Using the API

Run the [DeleteRoverNode](#) operation to delete a Roving Edge Infrastructure device node in Oracle Cloud Infrastructure.

Roving Edge Infrastructure Ultra Nodes

Describes how to manage your Roving Edge Ultra node requests in Oracle Cloud Infrastructure, including creating, updating, and deleting them.

Roving Edge Ultra is a single, battery-powered device capable of being carried by an individual. This product provides a highly-portable and rugged edge computing device you can use in indoor and outdoor environments. Roving Edge Ultra requires minimal protection from the elements, and is able to operate without consistent access to power. The device has less storage and computing capabilities than a traditional Roving Edge Infrastructure device node. Using Roving Edge Ultra provides you a level of portability and flexibility to use Roving Edge Infrastructure features and functionality not otherwise possible using traditional REDs.

Request a Roving Edge Ultra in the Oracle Cloud Infrastructure Cloud by accessing the Roving Edge Infrastructure service and creating a Roving Edge Ultra node resource. Roving Edge Ultra nodes are similar to Roving Edge Infrastructure device nodes except that the shapes are different. When you create the Roving Edge Ultra resource, you indicate the type of shape. The shape value you specify determines whether you are ordering a Roving Edge Ultra device or a Roving Edge Infrastructure device node. An Roving Edge Ultra node request includes the following required or optional components:

- User-defined name
- Predefined shape
- Compartment location in your Oracle Cloud Infrastructure tenancy
- Password
- Passphrase
- Shipping information (delivery to customer site or pickup from Oracle facility)
- Certificate
- Tagging
- One or more selected workloads, consisting of object storage, and compute instances residing on your Oracle Cloud Infrastructure tenancy. That content is preloaded onto the node and then made available to you by the delivery method you specify.

Note:

Ordering Oracle Roving Edge Infrastructure devices requires important terms and conditions to be understood and acknowledged before taking possession. Please confirm that these terms and conditions have been included as part of your Oracle Cloud agreement. Once Oracle validates your request, your Roving Edge Infrastructure are provisioned and available for your possession.

You can perform the following Roving Edge Ultra node management tasks:

- [Creating a Roving Edge Ultra Node](#)
- [Attaching a Workload to a Roving Edge Ultra Node](#)
- [Listing Workloads for a Roving Edge Ultra Node](#)
- [Deleting a Workload from a Roving Edge Ultra Node](#)
- [Submitting a Roving Edge Ultra Node](#)
- [Listing Roving Edge Ultra Nodes](#)
- [Listing Roving Edge Ultra Nodes Shapes](#)
- [Getting a Roving Edge Ultra Node's Details](#)
- [Editing a Roving Edge Ultra Node](#)

- [Moving a Roving Edge Ultra Node Between Compartments](#)
- [Deleting a Roving Edge Ultra Node](#)
- [Using USB Devices with Roving Edge Ultra Nodes](#) on page 146

Creating a Roving Edge Ultra Node

Create a Roving Edge Ultra node in Oracle Cloud Infrastructure.

These instructions create the Roving Edge Ultra node. After the Roving Edge Ultra node is created, you can attach an image workload and an Object Storage bucket workload to it before you submit it for approval (provisioning). Or you can attach workloads after the Roving Edge Ultra arrives. See [Attaching a Workload to a Roving Edge Ultra Node](#) on page 140.

Note:

Roving Edge Ultra node orders can only be shipped to specific countries depending on where the order is placed. Contact your Oracle account representative for more information. See [Country Support](#) for more information.

For information about Roving Edge models and shapes, see [Roving Edge Infrastructure Device Specifications](#) on page 10.

Using the OCI Console

1. Open the navigation menu and click **Hybrid**. Under **Roving Edge Infrastructure**, click **Nodes**. The **Nodes** page appears.
2. Click **Create Node**. The **Create Node** dialog box appears. Complete the following under **Basic information**:
 - **Name**: Enter a name for the Roving Edge Ultra node.
 - **Create in compartment**: Select the compartment in which the Roving Edge Ultra node you create resides from the list.
 - **Shape**: Select **ULTRA.USB.1.RX2.12** from the list. Select this shape option if you're configuring and requesting a Roving Edge Ultra node.
 - **Enclosure Type**: Select **Ruggedized**.

All Roving Edge Ultras include a ruggedized case.

3. Enter a **Super user password** and **Confirm the super user password**.

The password is for the super user account on the node.

Password requirements:

- Length: 8 - 12 characters
- Must include at least one: lowercase, numeric, and special character: ! # \$ % & () * + - . / : ; @ = < > [] ^ _ | ~ \ { }

4. Enter an **Unlock passphrase** and **Confirm unlock passphrase**.

The passphrase is used to decrypt data at rest on the node.

passphrase requirements:

- Length: 8 - 12 characters
- Must include at least one: lowercase, numeric, and special character: ! # \$ % & () * + - . / : ; @ = < > [] ^ _ | ~ \ { }

5. For **Shipping Information**. Choose one of the options:

- **Shipped by Oracle**: Complete the following shipping information:
 - **Point of contact**
 - **Care of**
 - **Recipient phone**

- **Recipient email**
 - **Country**
 - **Address line 1**
 - **Address line 2 (optional)**
 - **City/Locality**
 - **State/Province/Region**
 - **Zip/Postal code**
 - **Country:** Roving Edge Infrastructure device node orders can only be shipped to specific countries depending on where the order is placed. Contact your Oracle account representative for more information.
 - **Pickup from Oracle**
6. (optional) Expand **Certificate options**: Click to display and complete the following certificate options:
- **Common Name:** Enter a name for the certificate.
 - **Issuer Certificate Authority in <compartment>:** Select a certificate authority to be used for generating and renewing certificates for the device node. Click **Change Compartment** to select a certificate authority in another compartment.
 - **Certificate Validity End Date:** Enter the date and time on which the certificate is no longer valid.
 - **Signature Algorithm:** Select a signature algorithm from the list.
 - **Key Algorithm:** Select a key algorithm from the list.
 - **Certificate Compartment:** Select the compartment where the certificate resides.
7. (optional) **Show Tagging options**: Click to display the **Tagging** option. If you have permissions to create a resource, then you also have permissions to apply free-form tags to that resource. To apply a defined tag, you must have permissions to use the tag namespace.

Note:

If you are not sure about whether to apply tags, then skip this option (you can apply tags later) or ask your administrator.

Complete the following:

- **Tag Namespace**
- **Tag Key**
- **Value**

Click **+Another Tag** to add another tag. Click **X** to remove the associated tag.

See for descriptions of these fields.

8. Click **Create Node**.

The Roving Edge Ultra node you created is added to the list of nodes.

After creating the node, perform one of the following procedures:

- Submit a device node request. See [Submitting a Roving Edge Ultra Node Request](#) on page 143.
- Attach an image workload and an Object Storage bucket workload. See [Attaching a Workload to a Roving Edge Ultra Node](#) on page 140.

Using the CLI

Use the `oci rover node create` command and required parameters to create a Roving Edge Ultra node in Oracle Cloud Infrastructure:

```
oci rover node create --compartment-id compartment_ocid --display-name display_name --shape RED_USB_1_RX2_16 [OPTIONS]
```

To determine your Roving Edge Infrastructure device compartment OCID, see [Compartments](#).

The shape value `RED_USB_1_RX2_16` indicates you're creating a Roving Edge Ultra device node.

For a complete list of parameters and values for CLI commands, see the [CLI Command Reference](#).

After creating the node, perform one of the following procedures:

- Submit a device node request. See [Submitting a Roving Edge Ultra Node Request](#) on page 143.
- Attach an image workload and an Object Storage bucket workload. See [Attaching a Workload to a Roving Edge Ultra Node](#) on page 140.

Using the API

Run the [CreateRoverNode](#) operation to create a Roving Edge Ultra node in Oracle Cloud Infrastructure.

Attaching a Workload to a Roving Edge Ultra Node

Attach a workload to a Roving Edge Ultra node in Oracle Cloud Infrastructure.

Note:

Attach workloads *after* creating the Ultra device node.

Workloads determine the Oracle Cloud Infrastructure-based content that is included when an Roving Edge Ultra node is provisioned. When you request an Roving Edge Ultra node for provisioning, you can attach the available workloads associated with that node for inclusion. When your Roving Edge Ultra device arrives, it contains the content from the workloads you specified at the time of provisioning. Or you can attach workloads after the Roving Edge Ultra arrives.

Note:

The maximum size of an object you can use with Roving Edge Infrastructure devices is 5 TB. Any objects in your object store workload or any custom images greater than 5 TB in size are not be provisioned onto your Roving Edge Infrastructure device.

Workloads are managed as a resource within the Ultra device node, and you can attach, edit, and delete them. Each Ultra device node's Details page contains a link for viewing the associated workloads. The workloads are displayed in tabular form, and you can view the details of each workload, and perform tasks on them.

When you attach a workload to your Ultra device node, you specify the Oracle Cloud Infrastructure compartment and object storage bucket in which the content you want resides within your tenancy. You can also specify filters that ensure only the files you want are included.

Using the OCI Console

1. Open the navigation menu and click **Hybrid**. Under **Roving Edge Infrastructure**, click **Nodes**. The **Nodes** page appears.
2. Select the **Compartment** from the list under **List scope**. All device nodes in that compartment are listed in tabular form.
3. Select a **State** from the list under **Tag filters** to limit the device nodes displayed to that state.
4. Click the Roving Edge Ultra node to which you are attaching the workload. The Roving Edge Ultra node's **Details** page appears.
5. Click **Workloads** under **Resources**. A list of workloads appears.
6. Click **Attach workload** at the top of the workloads list. The **Attach workload** dialog box appears.
7. Provide the following information:
 - **Type:** Select one of the following options:
 - **Bucket in <compartment>:** Enter the name of the bucket where the files for the selected workload reside. The bucket name is what appears under the **Name** column in the **Workload** list.
 - **Prefix:** Enter a string to use for matching against the start of object names in a list query.
 - **Range Start:** Enter a value to which object names returned by a list query must be greater or equal.
 - **Range End:** Enter a value to which object names returned by a list query must be less.
 - **Image:** Complete the following:

- **VM Image in <compartment>**: Select one of the VM images available in the compartment. Click **Change Compartment** to select a different compartment.

8. Click **Attach Workload**.

The workload you attached appears in the **Workload** list of the Roving Edge Ultra node.

Using the CLI

Use the `oci rover node add-workload` command and required parameters to attach a workload to a Roving Edge Ultra node in Oracle Cloud Infrastructure:

```
oci rover node add-workload --compartment-id compartment_ocid --node-id node_ocid --type "bucket" [OPTIONS]
```

To determine your Roving Edge Infrastructure device compartment OCID, see [Compartments](#).

For a complete list of parameters and values for CLI commands, see the [CLI Command Reference](#).

Using the API

Run the `RoverWorkload` definition with the `CreateRoverNode` endpoint to attach a workload to a Roving Edge Ultra node in Oracle Cloud Infrastructure.

```
RoverWorkload:
  description: Rover workload
  type: object
  required:
    - id
    - compartmentId
    - workloadType
  properties:
    name:
      description: Name of the Rover Workload
      type: string
    compartmentId:
      description: The OCID of the compartment containing the workload.
      type: string
    id:
      description: The Unique Oracle ID (OCID) that is immutable on
      creation.
      type: string
    size:
      description: Size of the workload.
      type: string
    objectCount:
      description: Number of objects in a workload.
      type: string
    prefix:
      description: Prefix to filter objects in case it is a bucket.
      type: string
    rangeStart:
      description: Start of the range in a bucket.
      type: string
    rangeEnd:
      description: End of the range in a bucket.
      type: string
    workloadType:
      description: The type of workload
      type: string
```

Listing Workloads for a Roving Edge Ultra Node

Get a list of workloads attached to a Roving Edge Ultra node in Oracle Cloud Infrastructure.

Using the OCI Console

1. Open the navigation menu and click **Hybrid**. Under **Roving Edge Infrastructure**, click **Nodes**. The **Nodes** page appears.
2. Select the **Compartment** from the list under **List scope**. All device nodes in that compartment are listed in tabular form.
3. Select a **State** from the list under **Tag filters** to limit the device nodes displayed to that state.
4. Click the Roving Edge Ultra node whose workloads you want to list. The Roving Edge Ultra node's **Details** page appears.
5. Click **Workloads** under **Resources**.

All workloads attached to the Roving Edge Ultra node are listed in tabular form.

Using the CLI

Use the following [oci rover node list-workload](#) and required parameters to get a list of workloads attached to a Roving Edge Ultra node in Oracle Cloud Infrastructure:

```
oci rover node list-workload --node-id node_ocid [OPTIONS]
```

For a complete list of parameters and values for CLI commands, see the [CLI Command Reference](#).

Using the API

Run the `nodeWorkloads` attribute under [CreateRoverNodeDetails](#) to get a list of workloads attached to a Roving Edge Ultra node in Oracle Cloud Infrastructure.

Deleting a Workload from an Roving Edge Ultra Node

Delete a workload attached from a Roving Edge Ultra node in Oracle Cloud Infrastructure.

Using the OCI Console

1. Open the navigation menu and click **Hybrid**. Under **Roving Edge Infrastructure**, click **Nodes**. The **Nodes** page appears.
2. Select the **Compartment** from the list under **List scope**. All device nodes in that compartment are listed in tabular form.
3. Select a **State** from the list under **Tag filters** to limit the device nodes displayed to that state.
4. Click the Roving Edge Ultra node whose workload you want to delete. The Roving Edge Ultra node's **Details** page appears.
5. Click **Workloads** under **Resources**. All workloads attached to the Roving Edge Ultra node are listed in tabular form.
6. Click the Actions menu (⋮) for the workload you want to delete and select **Delete**.

The workload you deleted is removed from the list of workloads.

Using the CLI

Use the [oci rover node delete-workload](#) command and required parameters to delete a workload attached from a Roving Edge Ultra node in Oracle Cloud Infrastructure:

```
oci rover node delete-workload --node-id node_ocid [OPTIONS]
```

For a complete list of parameters and values for CLI commands, see the [CLI Command Reference](#).

Using the API

This task can't be performed using the API.

Submitting a Roving Edge Ultra Node Request

Submit a request for a Roving Edge Ultra node in Oracle Cloud Infrastructure.

Validation of the workloads associated with the submission takes approximately 10 minutes. During this time any attempt to access the node request can result in a 400 Bad Request error.

Important:

You cannot submit a Roving Edge Ultra device node for request unless you have attached at least one object workload and one image workload.

Using the OCI Console

1. Open the navigation menu and click **Hybrid**. Under **Roving Edge Infrastructure**, click **Nodes**. The **Nodes** page appears.
2. Select the **Compartment** from the list under **List scope**. All device nodes in that compartment are listed in tabular form.
3. Select a **State** from the list under **Tag filters** to limit the device nodes displayed to that state.
4. Click the Roving Edge Ultra node you are requesting being provisioned. The Roving Edge Ultra node's **Details** page appears.
5. Click **Submit for Approval**.

Using the CLI

Use the `oci rover node request-approval` command and required parameters to submit a request for a Roving Edge Ultra node in Oracle Cloud Infrastructure:

```
oci rover node request-approval --node-id node_ocid [OPTIONS]
```

For a complete list of parameters and values for CLI commands, see the [CLI Command Reference](#).

Using the API

This task can't be performed using the API.

Listing Roving Edge Ultra Nodes

List the Roving Edge Ultra nodes in Oracle Cloud Infrastructure.

Using the OCI Console

1. Open the navigation menu and click **Hybrid**. Under **Roving Edge Infrastructure**, click **Nodes**. The **Nodes** page appears.
2. Select the **Compartment** from the list under **List scope**. All device nodes in that compartment are listed in tabular form.
3. Select a **State** from the list under **Tag filters** to limit the device nodes displayed to that state.

All types of node are listed in tabular form. You can identify a node type by its shape:

- **RED.GPU.1.RX1.40**: Roving Edge Infrastructure device node
- **ULTRA.USB.1.RX2.12**: Roving Edge Ultra node

Using the CLI

Use the `oci rover node list` command and required parameters to list the Roving Edge Ultra nodes in Oracle Cloud Infrastructure:

```
oci rover node list --compartment-id compartment_ocid [OPTIONS]
```

To determine your Roving Edge Infrastructure device compartment OCID, see [Compartments](#).

For a complete list of parameters and values for CLI commands, see the [CLI Command Reference](#).

Using the API

Run the [ListRoverNodes](#) operation to list the Roving Edge Ultra nodes in Oracle Cloud Infrastructure.

Listing Roving Edge Ultra Node Shapes

List a Roving Edge Ultra node's shape in Oracle Cloud Infrastructure.

Using the OCI Console

This task can't be performed using the OCI Console.

Using the CLI

Use the [oci rover shape list](#) command and required parameters to list a Roving Edge Ultra node's shape in Oracle Cloud Infrastructure:

```
oci rover shape list --compartment-id compartment_ocid [OPTIONS]
```

To determine your Roving Edge Infrastructure device compartment OCID, see [Compartments](#).

For a complete list of parameters and values for CLI commands, see the [CLI Command Reference](#).

Using the API

This task can't be performed using the API.

Getting a Roving Edge Ultra Node's Details

Get the details of an Roving Edge Ultra node in Oracle Cloud Infrastructure.

Using the OCI Console

1. Open the navigation menu and click **Hybrid**. Under **Roving Edge Infrastructure**, click **Nodes**. The **Nodes** page appears.
2. Select the **Compartment** from the list under **List scope**. All device nodes in that compartment are listed in tabular form.
3. Select a **State** from the list under **Tag filters** to limit the device nodes displayed to that state.
4. Click the link for the Roving Edge Ultra node whose details you want to get.

The Roving Edge Ultra node's **Details** page appears.

Using the CLI

Use the [oci rover node show](#) command and required parameters to get the details of an Roving Edge Ultra node in Oracle Cloud Infrastructure:

```
oci rover node show --node-id node_ocid [OPTIONS]
```

For a complete list of parameters and values for CLI commands, see the [CLI Command Reference](#).

Using the API

Run the [GetRoverNode](#) operation to get the details of an Roving Edge Ultra node in Oracle Cloud Infrastructure.

Editing a Roving Edge Ultra Node

Edit a Roving Edge Ultra node in Oracle Cloud Infrastructure.

You cannot edit a Roving Edge Ultra node if you have already submitted it for approval.

Using the OCI Console

1. Open the navigation menu and click **Hybrid**. Under **Roving Edge Infrastructure**, click **Nodes**. The **Nodes** page appears.
2. Select the **Compartment** from the list under **List scope**. All device nodes in that compartment are listed in tabular form.
3. Select a **State** from the list under **Tag filters** to limit the device nodes displayed to that state.
4. Click the Roving Edge Ultra node that you want to edit. The Roving Edge Ultra node's **Details** page appears.
5. Click **Edit**. The **Edit Node** dialog box appears.
6. Make your edits. See [Creating an Ultra Node](#) for descriptions of the settings.
7. Click **Save changes**.

Using the CLI

Use the `oci rover node update` command and required parameters to edit an Roving Edge Ultra node in Oracle Cloud Infrastructure:

```
oci rover node update --display-name display-name --node-id node_ocid
[OPTIONS]
```

For a complete list of parameters and values for CLI commands, see the [CLI Command Reference](#).

Using the API

Run the [UpdateRoverNode](#) operation to edit an Roving Edge Ultra node in Oracle Cloud Infrastructure.

Moving a Roving Edge Ultra Node Between Compartments

Move an Roving Edge Ultra node between compartments in Oracle Cloud Infrastructure.

Using the OCI Console

1. Open the navigation menu and click **Hybrid**. Under **Roving Edge Infrastructure**, click **Nodes**. The **Nodes** page appears.
2. Select the **Compartment** from the list under **List scope**. All device nodes in that compartment are listed in tabular form.
3. Select a **State** from the list under **Tag filters** to limit the device nodes displayed to that state.
4. Click the Roving Edge Ultra node you want to move to a different compartment. The Roving Edge Ultra node's **Details** page appears.
5. Click **Move resource** under the **More actions** menu. The **Move resource** dialog box appears.
6. Select the compartment to which you want to move your Roving Edge Ultra node from the **Destination Compartment** list.
7. Click **Move resource**.

The Roving Edge Ultra node now appears in the nodes list within the compartment where you moved it.

Using the CLI

Use the `oci rover node change-compartment` command and required parameters to move an Roving Edge Ultra node between compartments in Oracle Cloud Infrastructure:

```
oci rover node change-compartment --compartment-id compartment_ocid --node-id node_ocid [OPTIONS]
```

To determine your Roving Edge Infrastructure device compartment OCID, see [Compartments](#).

compartment_ocid is the destination compartment.

For a complete list of parameters and values for CLI commands, see the [CLI Command Reference](#).

Using the API

Run the [ChangeRoverNodeCompartment](#) operation to move an Roving Edge Ultra node between compartments in Oracle Cloud Infrastructure.

Deleting a Roving Edge Ultra Node

Delete an Roving Edge Ultra node from Oracle Cloud Infrastructure.

Using the OCI Console

1. Open the navigation menu and click **Hybrid**. Under **Roving Edge Infrastructure**, click **Nodes**. The **Nodes** page appears.
2. Select the **Compartment** from the list under **List scope**. All device nodes in that compartment are listed in tabular form.
3. Select a **State** from the list under **Tag filters** to limit the device nodes displayed to that state.
4. Click the link for the Roving Edge Ultra node you want to delete. The Roving Edge Ultra node's **Details** page appears.
5. Click **Delete**.
6. Confirm the deletion when prompted.

The Roving Edge Ultra node you deleted no longer appears in the nodes list.

Using the CLI

Use the `oci rover node delete` command and required parameters to delete an Roving Edge Ultra node from Oracle Cloud Infrastructure:

```
oci rover node delete --node-id node_ocid [OPTIONS]
```

For a complete list of parameters and values for CLI commands, see the [CLI Command Reference](#).

Using the API

Run the [DeleteRoverNode](#) operation to delete a node.

Using USB Devices with Roving Edge Ultra Nodes

Use USB devices with Roving Edge Ultra devices.

The Roving Edge Ultra node now appears in the nodes list within the compartment where you moved it.

You can connect a USB device with your Roving Edge Ultra device and make it available to a virtual machine (VM) compute instance. For example, you can attach a camera to the OpenCV analytics workload, or attach a Mobius VPU to an inferencing workload.

Using a USB device with your Ultra device requires you create your VM compute instance using the Specialty shape type. The USB devices that you plug into the Ultra device become available to the VM instance using the PCI passthrough. See [Creating an Instance](#) on page 189 for more information.

Installing the Driver

Ensure that the image that you use to create the USB-shape VM has the driver needed to run the USB device. Unplug and then plug in the USB device to verify that the VM reports new network interfaces after plugging in the device. In Linux, the command to list the set of network interfaces is usually `ifconfig`.

If the VM cannot recognize the USB device, install the necessary driver. Consult with the device manufacturers for the drivers and installation instructions. You might need to enable some services and reboot the VM for the installed driver to run.

Tip:

After you confirm that the VM recognizes the USB device, Oracle recommends you create a machine image out from the VM for future use.

IP and Route Setup

For Wi-Fi dongles, refer to its documentation on how to connect to wireless networks.

For USB Ethernet adaptors, you might want to set up the respective network interfaces. Here are some Linux commands to help you set up the interfaces.

- Confirm the name of the USB Ethernet network interface: `ip addr sh | grep "inet"`
- Add an IP on the network interface: `sudo ip addr add IP/subnet_mask dev interface_name`
- Show all routes: `ip route sh`
- Show the route to a specific destination: `ip route get destination_IP/FQDN`
- Add a route: `sudo ip route add destination_IP/subnet_mask via gateway_IP dev interface_name`

You can adjust the `iptables` rules on the VM as well.

To check whether traffic goes through and arrives at specific destinations using the specific interface (and IP) as wanted, use the `ping` and `tcpdump` commands. For example:

- Ping a specific destination: `ping destination`
- Check if ping packets arrive at an interface: `sudo tcpdump -i interface_name icmp -n`

Alternatively, you can set up a DHCP server in the network to which the USB device is going to connect, so the VM with the USB-compatible shape has the network of the USB device set up automatically.

Attaching OCI Marketplace-Based Workloads

Include the OCI Marketplace applications in your attached workload when creating a Roving Edge Infrastructure node.

You can include selected applications from OCI Marketplace in the workloads you attach to a node, giving you access to Marketplace-based solutions in a limited- or disconnected environment using Roving Edge Infrastructure. You can only attach the solutions that are listed as "Free" or "Bring-your-own-license (BYOL)," and meet other Roving Edge Infrastructure compatibility requirements. These solutions are displayed using the "Roving Edge Exportable" filter in OCI Marketplace and are available for inclusion in a custom image that you can export to an Object Storage bucket in your OCI tenancy. These solutions contained in this exported custom image are preloaded from the Object Storage bucket into your Roving Edge Infrastructure environment, giving you full access to the OCI Marketplace applications without an internet connection requirement.

See [Overview of Marketplace](#) for a full description of how to use OCI Marketplace.

1. Access OCI Marketplace and select **All Applications**.

The **All Applications** page appears.

2. Select **Roving Edge Exportable** under **Filters**. Only those applications that you can export to Roving Edge Infrastructure are displayed. Each listing displays the type (Image only) and the pricing (Free or BYOL).
3. Select the listing you want to attach. The details for that listing appear.
4. Accept the Oracle terms of use and click **Launch Instance**. The **Create compute instance** dialog box appears.
5. Complete the compute instance configuration. See [Creating an Instance](#) for general information on creating instances.
6. Click **Create**. The **Details** page of the instance you created appears.
7. Select **Create custom image** from the **More Actions** menu. The **Create custom image** dialog box appears.

Note:

If **Create custom image** isn't available in the **More Actions** menu, it indicates the application that you selected isn't Roving Edge exportable (see Step 2).

8. Select the **Compartment** and **Name** for the custom image.
9. Click **Create custom image**. The **Work Request** page appears, displaying the status of the custom image creation. Wait until the page indicates that the custom image is created before continuing to the next step.
10. Open the **Compute** page and select **Custom Images**. The list of custom images in the selected compartment appears.
11. Click the custom image you want to export from the list. The **Details** page of the custom image you selected appears.
12. Click **Export**. The **Export image** dialog box appears.

Note:

If **Export** is not available in the **Details** page, it indicates that the application you selected isn't Roving Edge exportable (see Step 2).

13. Select the **Export to an Object Storage bucket** option.
14. Select the **Bucket in <compartment>** in which the custom image is exported from the list. Click **Change Compartment** to select a bucket in a different compartment.
15. Enter the **Image name** of the custom image.
16. Select the **Image format** from the list. The image format must be one of the following:
 - Oracle Cloud Infrastructure File with QCOW2 image and OCI metadata (.oci)
 - QEMU Copy on Write (.qcow2)
17. Click **Export Image**. The **Details** page of the Custom image appears. The Work Request list shows the status of the export job.

Roving Edge Infrastructure Device Monitoring

Describes how to monitor the system health and storage capacities of your Roving Edge Infrastructure components.

Important:

Don't allow your CPU usage to exceed 80%.

Important:

Plan the total storage needs of your Compute (boot volumes), Block Storage, and Object Storage resources in advance to ensure your storage doesn't exceed 80% of the total available storage. Then regularly monitor the available storage space to avoid oversubscription problems. If your storage

capacities reach 80% or higher, see [Avoiding Storage Overages Using Safe Mode](#) on page 38.

Monitoring Roving Edge Device Status

View the System Health page to get the status and capacities of Roving Edge Infrastructure Compute, Block Storage, and Object Storage.

1. Sign in to the Device Console.

The **System Health** page is displayed by default when you sign in.

If you've navigated away from the **System Health** page, you can return to it using the following methods:

- In the banner, click **Roving Edge Infrastructure**.
- In the navigation menu, select **Node Management**, then click **Nodes**.

On the **System Health** page, you can view capacity information about Compute, Block Storage, and Object Storage resources.

You can also click any of the panels to view details or perform a task.

Device Metrics

Describes how to enable, disable, and use metrics to describe services' trends and current performance.

You can enable and configure Roving Edge Infrastructure to generate metrics on device performance and health regarding block volume storage. These metrics are taken from the Roving Edge Infrastructure services and are placed in an InfluxDB 1.8 or later database that you must acquire and set up on a dedicated host database server. This machine can be co-located with your other computer hardware in your Roving Edge Infrastructure environment, or remotely if you have a working internet connection.

After your InfluxDB database is running you must configure and enable your Roving Edge Infrastructure devices to send data. You can subsequently review the metrics data by accessing the InfluxDB database.

Note:

You are responsible for maintaining the InfluxDB database.

Using the Device Console

1. Open the navigation menu and select **Node Management > Nodes**. The **Nodes** page appears.
2. Click **Configure metrics**. The **Configure metrics** dialog box appears.
3. Complete the following:
 - **Db URL**: Enter the URL for the InfluxDB database where the metrics data is sent.
 - **Organization**: Enter the name of the organization responsible for the InfluxDB.
 - **Bucket Name**: Enter the bucket name where metrics data is stored.
 - **API Token**: Enter the token used by the API to communicate with InfluxDB.
 - **Certificate**: (optional) Complete one of the following tasks:
 - **Upload certificate file**: Navigate to the certificate file (.pem) and upload it to the dialog box.
 - **Paste content**: Copy and past the certificate contents directly into the box.
4. Click **Enable**.

A banner appears indicating that the metrics service is enabled.

To disable metrics, follow the steps above to open the **Configure metrics** dialog box. Click **Disable**. Metrics are no longer available for the devices. A banner appears indicating that the metrics service is disabled.

Roving Edge Infrastructure Data Synchronization

Describes how to manage the transmission of object storage data between buckets on your Roving Edge Infrastructure devices and your Oracle Cloud Infrastructure tenancy. This update allows you to synchronize data between the Roving Edge Infrastructure devices and the Oracle Cloud Infrastructure cloud, and perform software updates.

You can perform the following data sync tasks:

- [Creating a Data Sync Task](#)
- [Listing Data Sync Tasks](#)
- [Getting a Data Sync Task's Details](#)
- [Editing a Data Sync Task](#)
- [Starting a Data Sync Task](#)
- [Stopping a Data Sync Task](#)
- [Deleting a Data Sync Task](#)

Note:

The maximum size of an object you can use with Roving Edge Infrastructure devices is 10 TiB. Any objects in your object store workload or any custom images greater than 10 TiB in size are not included in the data synchronization.

The following are the prerequisite tasks for performing a bi-directional data synchronization:

- Connect your Roving Edge Infrastructure device to your local site network, such as a site headquarters using the internet or FastConnect.
- Provide routing using the internet or FastConnect to an Oracle Cloud Infrastructure region.
- Specify the object storage buckets on Oracle Cloud Infrastructure that contain the data that needs to be preloaded on your Roving Edge Infrastructure device when your device is being provisioned.

Configure separate buckets to be either the source or destination of the transferred data. You cannot have bi-directional tasks or a task where the same pair of buckets reverse roles as bucket and source.

Note:

You cannot set up a bi-directional sync using two tasks and the same object storage buckets used by Oracle Cloud Infrastructure and the Roving Edge Infrastructure devices.

Creating a Data Sync Task

Describes how to create a data sync task for your Roving Edge Infrastructure devices.

Using the Device Console

1. Open the navigation menu and select **Data Sync**. The **Data Sync Tasks** page appears. All data synchronization tasks are listed in tabular form.
2. Click **Create Task**. The **Create Tasks** dialog box appears.
3. Enter the following:
 - Select the sync direction:
 - From **Oracle Cloud Infrastructure to Roving Edge Infrastructure** device: Push objects from the cloud to the device
 - From **Roving Edge Infrastructure device to Oracle Cloud Infrastructure**: Push objects from the device to the cloud
 - **OCI Bucket**: Complete the following:

- Enter the **Compartment ID**. This value is the OCID associated with the Oracle Cloud Infrastructure compartment in which your object storage bucket resides. You can find this OCID in the **Details** page of your compartment in the Oracle Cloud Infrastructure Console.
 - Enter the **OCI Bucket Name**. This value is the name of the object storage bucket containing the data on Oracle Cloud Infrastructure with which you are synchronizing with your data. You can find a list of your buckets in the Object Storage page in the Oracle Cloud Infrastructure Console.
 - **RED Bucket**: Select one of the following options:
 - **Select an existing bucket**: Select an existing bucket from the **RED Bucket Name** list.
 - **Create a new bucket**: Enter the name of the bucket you are creating in the **RED Bucket Name** box.
 - **Rate Limit**: Select the rate limit in which objects and synchronized data transferred between the device and Oracle Cloud Infrastructure from the **Bandwidth** list. Default is "No Limit."
 - **Schedule**: Complete the following to schedule your device's data sync activities:
 - **Start Date**: Enter or use the Calendar feature to specify the start date of the time period when the scheduled data sync activity occurs.
 - **End Date**: Enter or use the Calendar feature to specify the end date of the time period when the scheduled data sync activity occurs.
 - **Frequency**: Select the frequency of the data syncs from the list. Available options are Hourly, Daily, Weekly, or Monthly. If you select weekly, the day of the week is determined based on the start date.
 - **Sync Start Time**: Select the time of day when the data sync begins.
 - **Sync on Last Day of Each Month**: Check to perform a data sync on the last day of the month.
 - **Schedule Priority**: Select the priority in which competing tasks are started first when they have the same run time. This priority does not interrupt currently running tasks. Available options are **High, Medium, and Low**.
 - **Sync on Reconnect**: Check for the device to automatically run a data sync anytime the device is reconnected to Oracle Cloud Infrastructure.
 - Check **Sync on Create** to begin the synchronization after the task is created.
4. Click **Save**.

If you checked the **Sync on Create** option, the data sync task begins immediately. If you did not check this option, you can start the data sync task by checking the task in the **Data Sync Tasks** page and clicking **Start**.

For **Roving Edge Infrastructure device to Oracle Cloud Infrastructure** data syncs, click the **Source Bucket** link for the task you just ran after it completes. The bucket's **Details** page appears, listing those files that were uploaded from your Roving Edge Infrastructure device to your Oracle Cloud Infrastructure destination.

For **Oracle Cloud Infrastructure to Roving Edge Infrastructure device** data syncs, click the **Destination Bucket** link for the task you just ran after it completes. The bucket's **Details** page appears, listing those files that were downloaded into it.

Listing Data Sync Tasks

Describes how to list the data sync tasks for your Roving Edge Infrastructure devices.

Using the Device Console

1. Open the navigation menu and select **Data Sync**.

The Data Sync Tasks page appears. All data synchronization tasks are listed in tabular form.

2. (optional) Select a **Status** from the list to limit the data sync tasks displayed to that status.

Getting a Data Sync Task's Details

Describes how to get the details of a data sync tasks for your Roving Edge Infrastructure devices.

1. Open the navigation menu and select **Data Sync**. The **Data Sync Tasks** page appears. All data sync tasks are listed in tabular form.
2. (optional) Select a **Status** from the list to limit the data sync tasks displayed to that status.

3. Select the Actions menu (⋮) for the data sync task whose details you want to get and click **View Details**. The task's **Details** page appears.

Using the Device Console

1. Open the navigation menu and select **Data Sync**. The **Data Sync Tasks** page appears. All data synchronization tasks are listed in tabular form.
2. (optional) Select a **Status** from the list to limit the data sync tasks displayed to that status.
3. Select the Actions menu (⋮) for the data sync task whose details you want to get and click **View Details**. The task's **Details** page appears.

Editing Data Sync Tasks

Describes how to edit a data sync task for your Roving Edge Infrastructure devices.

1. Open the navigation menu and select **Data Sync**. The **Data Sync Tasks** page appears. All data sync tasks are listed in tabular form.
2. (optional) Select a **Status** from the list to limit the data sync tasks displayed to that status.
3. Select the Actions menu (⋮) for the data sync task that you want to edit and click **Edit**. The **Edit Task** dialog box appears.
4. Make your edits. See [Creating a Data Sync Task](#) for descriptions of the settings.
5. Click **Save**.

Using the Device Console

1. Open the navigation menu and select **Data Sync**. The **Data Sync Tasks** page appears. All data synchronization tasks are listed in tabular form.
2. (optional) Select a **Status** from the list to limit the data sync tasks displayed to that status.
3. Select the Actions menu (⋮) for the data sync task that you want to edit and click **Edit**. The **Edit Task** dialog box appears.
4. Make your edits. See [Creating a Data Sync Task](#) for descriptions of the settings.
5. Click **Save**.

Starting a Data Sync Task

Describes how to start a data sync task for your Roving Edge Infrastructure devices.

1. Open the navigation menu and select **Data Sync**. The **Data Sync Tasks** page appears. All data sync tasks are listed in tabular form.
2. (optional) Select a **Status** from the list to limit the data sync tasks displayed to that status.
3. Check the data sync task that you want to start.
4. Click **Start**. Alternately, select the Actions menu (⋮) for the data sync task that you checked and click **Start**.
5. Confirm the start when prompted.

Stopping a Data Sync Task

Describes how to stop a data sync task in progress for your Roving Edge Infrastructure devices.

1. Open the navigation menu and select **Data Sync**. The **Data Sync Tasks** page appears. All data sync tasks are listed in tabular form.
2. (optional) Select a **Status** from the list to limit the data sync tasks displayed to that status.
3. Check the data sync task that you want to stop.

4. Click **Stop**. Alternately, select the Actions menu (⋮) for the data sync task that you checked and click **Stop**.
5. Confirm the stop when prompted.

Note:

You can only stop a data sync task that has already started.

Deleting a Data Sync Task

Describes how to delete a data sync task from your Roving Edge Infrastructure devices.

1. Open the navigation menu and select **Data Sync**. The **Data Sync Tasks** page appears. All data sync tasks are listed in tabular form.
2. (optional) Select a **Status** from the list to limit the data sync tasks displayed to that status.
3. Check the data sync tasks that you want to delete.
4. Select the Actions menu (⋮) for the data sync task you checked and click **Delete**.
5. Confirm the deletion when prompted.

Roving Edge Infrastructure Device Software Version Management

Describes how to manage the system software, including software updates and rollbacks, on your Roving Edge Infrastructure devices in both a connected (online) and disconnected (offline) state.

You can perform the following Roving Edge Infrastructure device software version management tasks:

- [Identify the device software version.](#)
- [Update the software while the device is **connected** to the Oracle Cloud Infrastructure Cloud](#)
- [Update the software while the device is **disconnected** from the Oracle Cloud Infrastructure Cloud.](#) You must have the required permissions to perform a software update on a disconnected Roving Edge Infrastructure device. See [Enabling Disconnected Upgrade Bundle Delivery](#) on page 64. This capability was introduced in Roving Edge software version 2.6.
- [Roll back the software to the device's previous version](#)

Note:

You are responsible for regularly checking your Roving Edge Infrastructure device system software and updating the software as needed.

Identifying the Device Software Version

You can identify the Roving Edge Device software version using the Device Console or the Serial Console.

Using the Device Console

1. Sign in to the Device Console.
2. In the navigation menu, click **Node Management**, then click **Nodes**.

The version is displayed in the **Version** column.

Using the Serial Console

Prerequisites

You must have a controlling host, such as a laptop connected to the device serial port (see [Cable the Roving Edge Device](#) on page 32) and have terminal emulation configured (see [Set Up Terminal Emulation](#) on page 33).

For information about the serial console menu, see [Operating the Serial Console](#) on page 37.

1. In your terminal emulation utility, with the main menu displayed, select 4) Show Status.

The version is listed in the device status output:

```

Roving Edge Device
-----

1) Unlock Device
2) Change Passphrase
3) Configure Networking
4) Show Status
5) Show System Diagnostics
6) Shutdown Device
7) Reboot Device
8) Enter Safe-Mode
9) Exit Safe-Mode
10) Shred Key
11) Recover Key
12) Reset Device
13) Advanced Menu
14) Cluster Health
15) Node Health
16) Diagnostics
17) Help

Device Status:

Version                : 2.14.0.20240812082011
System Time UTC        : 2024-08-19 21:20:37
Boot Time              : 2024-08-12 08:46:01
Device Serial Id       : vml-bm-xyz
Unlock Status          : UNLOCKED
Auto Unlock Status     : Disabled
Diag Mode              : Disabled
red-1 API Services Status : All Services Are Available
red-1 HW Services Status  : All Services Are Available
Press ENTER to return...

```

Updating the Roving Edge Infrastructure Device Software while Connected

Describes how to updating the Roving Edge Infrastructure device software while the device is connected to the internet.

Software update versions are not cumulative to the preceding versions. If your Roving Edge Infrastructure device is more than one software version behind the latest version, you must update to each subsequent version individually until you are current with the latest version.

The size of the update is currently around 20 GB with potential to grow or shrink with time. Download time is determined by the update size and your network bandwidth. For example, with a 10 MBPS download connection, it would take approximately 30 minutes.

When you begin the update, the Roving Edge Infrastructure device waits 60 seconds for all running VMs to shut down. If you have VMs that take longer than 60 seconds to shut down, shut them down yourself before performing the update.

1. Access the Device Console for the device node you are configuring for a system update.
2. Click the **System Status** icon () in the upper right corner of the RED Console. The **System Upgrades** dialog box appears, indicating any available software updates. It also displays your current software version and version number of the software update.
3. Click **Download Update**. The software bundle for the update is downloaded onto your Roving Edge Infrastructure device. The **System Upgrade** dialog box indicates when the download is complete and ready for installation

4. Open the navigation menu and select **Node Management > Nodes**. The **Nodes** page appears. All of the device nodes are listed in tabular format.
5. Click **Upgrade** next to the device node you want to update. Confirm the update request. The **System Upgrades** dialog box indicates the progress of the upgrade. The device is automatically rebooted at the end of the update process. You must unlock the rebooted device using the Serial Console. See [Unlock the Device](#) on page 35.

Updating the Roving Edge Infrastructure Device Software while Disconnected

Describes how to update the Roving Edge Infrastructure device software while the device isn't connected to the internet.

Note:

The ability to update device software while the device is disconnected was introduced in Roving Edge software version 2.6. If your device is running an earlier version (2.5 or earlier), you must [update the device software while connected](#). To find your device software version, see [Identifying the Device Software Version](#) on page 153.

You can update your Roving Edge Infrastructure device's system software while in a disconnected or offline state. Request a system update through your device's Roving Edge Infrastructure **Node** resource in the Oracle Cloud Infrastructure Cloud. After the update bundle is copied to the destination bucket, download it to a local device such as a laptop computer. Upload the system update bundle to your Roving Edge Infrastructure device using object storage.

You must have the required permissions to perform a software update on a disconnected Roving Edge Infrastructure device. See [Enabling Disconnected Upgrade Bundle Delivery](#) on page 64.

Upgrading your Roving Edge Infrastructure device's system software while in a disconnected state is only available for individual device nodes.

1. Access the Device Console for the device node you are configuring for a system update.
2. Click the **System Status** icon () in the upper right corner of the Device Console. The **System Upgrades** dialog box appears, indicating any available software updates. It also displays your current software version and version number of the software update.
3. Record the current system software version. You will use it later in the update.
4. Log into the Oracle Cloud Infrastructure Cloud Console.
5. Open the navigation menu and click **Hybrid**. Under **Roving Edge Infrastructure**, click **Nodes**. The **Nodes** page appears.
6. Select the **Compartment** from the list. All nodes in that compartment are listed in tabular form.
7. Select **Active** under **State**. Your device must be in the **Customer Received** or **Customer Deployed** as listed in the state details to request a system update bundle.
8. Click the device node that you want to configure for disconnected system update. The **Node Details** page appears.
9. Click **System Upgrades** under **Resources**. The **System Upgrade Bundle Request** list appears. All the system update requests are listed in tabular form. The upgrade bundles only remain listed for 48 hours. Previously-completed bundle transfers remain in object storage indefinitely until you remove them.
10. Click **Request System Upgrade Bundle**. The **Request Node Upgrade Bundle** dialog box appears.
11. Take the current system software version of the device that you recorded at the beginning of these steps, and enter it in the **Current Software Version** box and click **Get Next Upgrade Version**. The version number you enter is compared with the available update bundles to see which is the appropriate match. The best match is displayed in the **Compatible Upgrade Version** box. In some cases, you might need to perform an interim system software update before you can perform the update you want. The **Compatible Upgrade Version** box ensures you follow the required update order.
12. Select a bucket from the **Destination Bucket** list. The bucket you select receives the system bundle you are requesting. Click **Change Compartment** if you want to select a destination bucket residing in a different compartment.

13. Click **Request System Upgrade Bundle**. The **System Upgrade Bundle Requests** list shows the transfer progress for the bundle to the specified destination bucket. Click **View Details** from the **Action** menu to show more information in the system update bundle request.

As an alternative to using the Oracle Cloud Infrastructure Cloud Console to perform device software update tasks, you can use the following command line interface tools:

- **Getting the compatible upgrade version:** Run the `oci rover node rover-bundle-version get` command and required parameters to get the compatible upgrade version for a Roving Edge Infrastructure device:

```
oci rover node rover-bundle-version get --current-rover-bundle-
version current_rover_bundle_version
--rover-node-id rover_node_ocid [OPTIONS]
```

- **Listing the upgrade bundle requests:** Run the `oci rover node rover-bundle-request list` command and required parameters to list the upgrade bundle requests for a Roving Edge Infrastructure device:

```
oci rover node rover-bundle-request list --rover-node-id rover_node_ocid
[OPTIONS]
```

- **Requesting a system upgrade bundle:** Run the `oci rover node rover-bundle copy-to-customer` command and required parameters to request a system upgrade bundle for a Roving Edge Infrastructure device

```
oci rover node rover-bundle copy-to-customer --bundle-
version bundle_version
--destination-bucket-
name destination_bucket_name --destination-compartment-
id destination_compartment_ocid
--rover-node-id rover_node_ocid [OPTIONS]
```

- **Viewing the transfer progress for an upgrade request:** Run the `oci rover node rover-bundle get-status` command and required parameters to view the transfer progress for an upgrade request for a Roving Edge Infrastructure device:

```
oci rover node rover-bundle get-status --rover-node-id rover_node_ocid
--work-request-id work_request_ocid [OPTIONS]
```

14. After your upgrade bundle request has completed transferring, access it from the destination bucket on Oracle Cloud Infrastructure object storage. Download the upgrade bundle to the local computer or laptop from which you are accessing OCI. See [Downloading an object](#).

Note:

System update bundles can be very large. They can take a long time to download. Plan accordingly.

15. Copy the downloaded bundle to a laptop or computer that you can connect to the same network as the Roving Edge Infrastructure device.
16. Upload the system update bundle from the storage device to your Roving Edge Infrastructure device. See [Uploading an Object to an Object Storage Bucket on a Device](#) on page 233. Copy the bundle to the "rover-system-upgrade-staging" bucket in object storage.
17. Review how to set up and use the CLI as described in [Using the Command Line Interface](#). After the bundle is uploaded to the bucket, open a command line window and run the `oci rover device system-upgrade upload-bundle` command:

```
oci rover device system-upgrade upload-bundle --
endpoint object_storage_endpoint --file bundle_file_path
```

You can then view all import tasks by running the `oci rover device system-upgrade get-import-history` command:

```
oci rover device system-upgrade get-import-history --
endpoint upgrade_endpoint
```

To view a specific task, run the `oci rover device system-upgrade get-import-status` command:

```
oci rover device system-upgrade get-import-status --
endpoint upgrade_endpoint --task-id task_ocid --wait true/false
```

To start the upgrade, run the `oci rover device system-upgrade import-bundle` command:

```
oci rover device system-upgrade import-bundle --object-name object_name
```

where *object_name* is the name of the object/release bundle. For example:
2.5.3.20230808163434.rover_disconnected_release.tar.

After the import status indicates "COMPLETED", you can proceed with the normal system software update using the Device Console.



18. Click the **System Status** icon () in the upper right corner of the Device Console. The **System Upgrades** dialog box displays the time stamp and name of the system update bundle, as well as the status of the various stages during the upload process. When the upload is complete, the dialog box displays the device's current system software version and the new version installed from the system update bundle.
19. Open the navigation menu and select **Node Management > Nodes**. The **Nodes** page appears. All of the device nodes are listed in tabular format.
20. Click **Upgrade** next to the device node you want to update. Confirm the update request. The software version you selected is downloaded onto your Roving Edge Infrastructure device. The **System Upgrades** dialog box indicates when the installation is complete.

The device is automatically rebooted at the end of the update process. You must unlock the rebooted device using the Serial Console. See [Unlock the Device](#) on page 35.

Rolling Back the Roving Edge Infrastructure Device Software to the Previous Version

Describes how to roll back the Roving Edge Infrastructure device's software to the previously-installed version.

You can only roll back a device's system software once per software version. If you have already rolled back your system software from what had been your current version, you cannot roll the system software back a subsequent time to revert to an even earlier software version.

1. Access the Device Console for the device node's software you want to roll back.
2. Open the navigation menu and select **Node Management > Nodes**. The **Nodes** page appears. All of the device nodes are listed in tabular format.
3. Click the Actions menu () of the device node whose software you want to roll back and select **Rollback** from the list of commands. Confirm the rollback. Your Roving Edge Infrastructure device's software is rolled back to the previous version.
4. Click the **System Status** icon () in the upper right corner of the Device Console. The **System Upgrades** dialog box now indicates that a newer software version (the one you from which you just rolled back) is available.

Collecting Roving Edge Infrastructure Device Diagnostic Information

Learn how to collect diagnostic information related to Roving Edge Infrastructure devices and forward them to Oracle Support for further investigation of potential problems.

Use the diagnostic bundles feature to collect diagnostic information for Roving Edge Infrastructure devices and send them to Oracle Support where the data can be further reviewed and recommendations made on how to fix problems and improve performance. The feature gathers logs regardless of the health of core services like data-sync, object storage, databases and identity. Once you download a diagnostic bundle, submit it to Oracle Support by using a [Service Request](#).

You can perform the following device diagnostic bundles tasks:

- [Creating a diagnostic bundle](#)
- [Listing the diagnostic bundles for a device](#)
- [Getting the details of a diagnostic bundle](#)
- [Downloading a diagnostic bundle to your local computer](#)
- [Cancelling a diagnostic bundle in progress](#)

Creating a Diagnostic Bundle for a Roving Edge Infrastructure Device

Create a diagnostic bundle for a Roving Edge Infrastructure device that you can send to Oracle for further review and analysis.

Using the Device Console

1. Open the navigation menu and select **Node Management > Diagnostic Bundles**. The **Diagnostic Bundles** page appears.
2. Click **Create Bundle**. The **Create Diagnostic Bundle** dialog box appears.
3. Enter a **Bundle Name** for the diagnostic bundle.
4. Select a specific device node from the **Node** list to create a diagnostic bundle for just that node.
5. Select **Include Core Files** to include core files in the bundle.
6. Click **Create**.

The diagnostic bundle you created appears in the list in the **Diagnostic Bundles** page.

Listing Diagnostic Bundles for a Roving Edge Infrastructure Device

Describes how to list diagnostic bundles for a Roving Edge Infrastructure device.

Using the Device Console

Open the navigation menu and select **Node Management > Diagnostic Bundles**. The **Diagnostic Bundles** page appears.

All the diagnostic bundles are listed in tabular form.

Getting a Diagnostic Bundle's Details for Roving Edge Infrastructure Devices

Describes how to get the details of a diagnostic bundle for a Roving Edge Infrastructure device.

Using the Device Console

1. Open the navigation menu and select **Node Management > Diagnostic Bundles**. The **Diagnostic Bundles** page appears. All the diagnostic bundles are listed in tabular form.
2. Click the diagnostic bundle whose details you want to get.

The diagnostic bundle's **Details** page appears. The **Details** page includes information regarding the diagnostic bundle, including the OCID, time of creation, and whether core files are included. You can also access the **Bundles** and **Errors** pages under **Resources** where you can view additional information.

Downloading a Diagnostic Bundle for a Roving Edge Infrastructure Device

Describes how to download a completed diagnostic bundle for a Roving Edge Infrastructure device to your local computer.

Using the Device Console

1. Open the navigation menu and select **Node Management > Diagnostic Bundles**. The **Diagnostic Bundles** page appears. All the diagnostic bundles are listed in tabular form.
2. Click the diagnostic bundle that you want to download. The diagnostic bundle's **Details** page appears.
3. Click **Bundles** under **Resources**. The **Bundles** page appears.
4. Wait until the diagnostic bundle is in a **Completed** state, then proceed to the next step.
5. Click the the Actions menu (⋮) to the right of the diagnostic bundle and select **Download Bundle**. The **Download Diagnostic Bundle** dialog box appears.
6. Click **Download**. The diagnostic bundle is downloaded to your local computer as a `tar.gz` file. This file is encrypted. You must decrypt it before you can forward it to Oracle Support.
7. Open a command prompt window and navigate to where the diagnostic bundle was downloaded on your computer.
8. Decrypt the diagnostic bundle by running the following command at the prompt:

```
openssl enc -aes-128-cbc -d -K $encryption_key -iv $encryption_key -in /tmp/bundle.tar.gz -out /tmp/decrypted-bundle.tar.gz
```

where `$encryption_key` is the encryption key you can access from the device's Serial Console. See [Displaying the Serial Encryption Key](#) on page 41.

9. Open an Oracle Support Request and upload the decrypted diagnostic bundle as part of your support request ticket. See [My Oracle Support](#) for more information.

Canceling a Diagnostic Bundle for a Roving Edge Infrastructure Device in Progress

Describes how to cancel the generating of a diagnostic bundle while in progress for a Roving Edge Infrastructure device.

Using the Device Console

1. Open the navigation menu and select **Node Management > Diagnostic Bundles**. The **Diagnostic Bundles** page appears. All the diagnostic bundles are listed in tabular form.
2. Click the diagnostic bundle that you want to cancel. The diagnostic bundle's **Details** page appears.
3. Perform one of the following tasks depending on what you want to do:
 - **Cancel all diagnostic bundles for all nodes that are still in progress:** Click **Cancel** at the top of the **Details** page.
 - **Cancel the diagnostic bundle associated with a particular node:** Click the the Actions menu (⋮) to the right of the diagnostic bundle and select **Cancel Bundle**.
4. Click **Confirm** when the **Cancel Diagnostic Bundle** dialog box appears.

Those bundles display their canceled status in the **Bundles** page.

Running Roving Edge Infrastructure Device Diagnostic Commands

Learn how to use diagnostic commands to run pre-defined commands on your Roving Edge Infrastructure devices for quick troubleshooting.

Note:

Currently, only VNIC Packet Capture is supported by these diagnostic commands.

You can perform the following device diagnostic command tasks:

- [Creating a diagnostic command](#)
- [Listing diagnostic commands](#)
- [Getting a diagnostic command's details](#)
- [Downloading a diagnostic command](#)
- [Canceling a diagnostic command in progress](#)

Creating a Diagnostic Command for a Roving Edge Infrastructure Device

Describes how to create a diagnostic command for a Roving Edge Infrastructure device.

Begin by recording the OCID of the attached VNIC. After you record that OCID, you can continue on to create the diagnostic command.

Using the Device Console

1. Open the navigation menu and select **Compute > Instances**. The **Instances** page appears. All instances are listed in tabular form.
2. Click the instance that has the attached VNIC whose OCID you want to get. The instance's **Details** page appears.
3. Click **Attached VNICs** under **Resources**. The **Attached VNICs** page appears. All attached VNICs are listed in tabular form. The primary VNIC is indicated by the **Primary VNIC** label next to it.
4. Click the attached primary VNIC whose OCID you want to get. The VNIC's **Details** page appears.
5. The VNIC's OCID appears under **VNIC Information**. Click **Copy** to copy the OCID and subsequently paste it in the **VNIC OCID** box in the **Create Diagnostic Command** dialog box.
6. Open the navigation menu and select **Node Management > Diagnostic Commands**. The **Diagnostic Commands** page appears. All diagnostic commands are listed in tabular form.
7. Click **Create Command**. The **Create Diagnostic Command** dialog box appears.
8. Enter a **Name** for the diagnostic command.
9. Select the **Command Type** from the list.

Note:

Currently, only **VNIC Packet Capture** is available as a command type.

10. Enter the **VNIC OCID**.
11. Select the **Packet Length** in bytes from the list.
12. Select the **Capture Duration** in seconds from the list.
13. Click **Create Command**.

The diagnostic command you created appears in the list in the **Diagnostic Commands** page.

Listing Diagnostic Command for a Roving Edge Infrastructure Device

Describes how to list the diagnostic commands for a Roving Edge Infrastructure device.

Using the Device Console

1. Open the navigation menu and select **Node Management > Diagnostic Commands**. The **Diagnostic Commands** page appears.
2. Select a **Command Type** from the list to limit the diagnostic commands displayed to that type.

All diagnostic commands are listed in tabular form.

Getting a Diagnostic Command's Details for a Roving Edge Infrastructure Device

Describes how to get the details of a diagnostic command for a Roving Edge Infrastructure device.

Using the Device Console

1. Open the navigation menu and select **Node Management > Diagnostic Commands**. The **Diagnostic Commands** page appears. All diagnostic commands are listed in tabular form.
2. Select a **Command Type** from the list to limit the diagnostic commands displayed to that type.
3. Click the diagnostic command whose details you want to get. The diagnostic command's **Details** page appears.

The diagnostic command's **Details** page appears. The **Details** page include information such as the diagnostic command's OCID, the packet length, and the capture duration.

Downloading a Diagnostic Command's Output for a Roving Edge Infrastructure Device

Describes how to download a diagnostic command output for a Roving Edge Infrastructure device.

Using the Device Console

1. Open the navigation menu and select **Node Management > Diagnostic Commands**. The **Diagnostic Commands** page appears. All the diagnostic commands are listed in tabular form.
2. Select a **Command Type** from the list to limit the diagnostic commands displayed to that type.
3. Click the diagnostic command whose output you want to download. The diagnostic command's **Details** page appears.
4. Click **Command Output** under **Resources**. The **VNIC Packet Capture** page appears.
5. Wait until the diagnostic command is in a **Completed** state, then proceed to the next step.
6. Click the the Actions menu (⋮) to the right of the diagnostic command and select **Download Command Output**. The **Download Command Output** dialog box appears.
7. Click **Download**. The diagnostic command output is downloaded to your local computer as a `tar.gz` file. You can extract the diagnostic output file content using your favorite extraction tool, and view the diagnostic information.

Canceling a Diagnostic Command in Progress for a Roving Edge Infrastructure Device

Describes how to cancel a diagnostic command in progress for a Roving Edge Infrastructure device.

You can only cancel a diagnostic command while it is still in the **Accepted** or **In Progress** state.

Using the Device Console

1. Open the navigation menu and select **Node Management > Diagnostic Commands**. The **Diagnostic Commands** page appears. All the diagnostic commands are listed in tabular form.
2. Select a **Command Type** from the list to limit the diagnostic commands displayed to that type.
3. Click the diagnostic command you want to cancel in progress. The diagnostic command's **Details** page appears.
4. Click **Command Output** under **Resources**. The **VNIC Packet Capture** list appears.
5. Ensure the diagnostic command is still in an **Accepted** or **In Progress** state, then proceed to the next step.
6. Click the the Actions menu (⋮) to the right of the diagnostic command and select **Cancel Command**. The **Cancel Diagnostic Command** dialog box appears.
7. Click **Cancel Command**.

The **VNIC Packet Capture** list displays **CANCELING** next to the diagnostic command. When the cancellation is complete, the state changes to **CANCELED**.

Certificate Management

Describes how to manage your Roving Edge Infrastructure devices' certificates.

You can view and manage your Roving Edge Infrastructure device nodes' certificates and certificate actions through the **Node Management** section in your node's Device Console. Each device node has a certificate on it that is created when the device node is provisioned. For each device node, only the latest version of the certificate and the latest action performed on that certificate is maintained. If you create a new certificate, that certificate will be the only one that is visible and the previous certificate is no longer maintained or usable.

Note:

Oracle recommends that you to use different Certificate Authorities (CAs) for each order. You can use the same root CA, but use different subordinate CAs. If you use the same CA for all your Roving Edge Infrastructure devices, a compromise in the common root/subordinate CA results in a compromise for all the devices using it.

You can perform the following device node certificate management tasks for your device node:

- [Getting a certificate's details](#)
- [Getting a CA bundle's details](#)
- [Updating the certificate's details](#)
- [Renewing an existing certificate for a connected device node](#)
- [Renewing a certificate for a disconnected device node](#)
- [Creating a certificate for a connected device node](#)
- [Creating a certificate for a disconnected device node](#)

Renew vs. Create Certificate

You have the option of both renewing an existing certificate on your device node, or creating a new certificate that replaces the existing certificate. Deciding on which action to take depends on whether the subject information used for the certificate is changing. If so, then creating a new certificate incorporates those changes whereas renewing the certificate does not. If no subject information used for the certificate has changed on the device node, then renewing the certificate is sufficient.

Getting a Certificate's Details for a Roving Edge Infrastructure Device

Describes how to view the details of a certificate for a Roving Edge Infrastructure device node.

Using the Device Console

1. Access the Device Console for the device node for which you are creating the certificate.
2. Open the navigation menu and click **Node Management > Certificates**. The **Certificates** page appears. Each Roving Edge Infrastructure device node's certificate is listed.
3. Click **View** under the **Action** menu (three dots at the right of the node entry) whose certificate you want to view. The **View certificate** dialog box opens.

The **View certificate** dialog box contains various items of information regarding the certificate. It also contains the **Certificate PEM** and **CA Bundle PEM** certificates that you can copy and paste where needed, or download to your local computer.

Getting a Certificate Authority (CA) Bundle's Details for a Roving Edge Infrastructure Device

Describes how to get the details of a CA bundle for a Roving Edge Infrastructure device node.

Using the Console

1. Access the Device Console for the device node for which you are creating the certificate.
2. Open the navigation menu and click **Node Management > Certificates**. The **Certificates** page appears. Each Roving Edge Infrastructure device node's certificate is listed.

3. Click **View** under the **Action** menu (three dots at the right of the node entry) whose certificate you want to view. The **View certificate** dialog box opens.

The **View certificate** dialog box contains various items of information regarding the certificate. It also contains the **Certificate PEM** and **CA Bundle PEM** certificates that you can copy and paste where needed, or download to your local computer.

Updating Certificate Details for a Roving Edge Infrastructure Device

Describes how to make changes to edit certificate for a Roving Edge Infrastructure device node.

Use the updating certificate details feature to update any combination of the certificate authority, key algorithm and signature algorithm the Roving Edge Infrastructure device node uses to create certificates. First, make the updates on the Oracle Cloud Infrastructure Cloud Console. Next, create a certificate by following the instructions depending on your device node's connected state or disconnected state.

Using the OCI Cloud Console

1. Access the Oracle Cloud Infrastructure Cloud Console.
2. Open the navigation menu and click **Hybrid**. Under **Roving Edge Infrastructure**, click **Nodes**. The **Nodes** page appears.
3. Click the nodes whose certificate details you want to update. The **Details** page of the node appears.
4. Click **Update Node Certificate Details** from the **More Actions** menu. The **Update Node Certificate Details** dialog box appears.
5. Update any of the following items:
 - **Issuer Certificate Authority in <compartment>**: Select a certificate authority to be used for generating and renewing certificates for the device node. Click **Change Compartment** to select a certificate authority in another compartment.
 - **Signature Algorithm for Certificate**: Select a signature algorithm from the list.
 - **Key Algorithm**: Select a key algorithm from the list.
6. Click **Save Changes**. The **Details** page displays a message confirming the certificate details for the device node were successfully updated.
7. Continue on with the subsequent steps in the following topics depending on whether your device node is in a connected or disconnected state:
 - [Creating a certificate while connected](#)
 - [Creating a certificate while disconnected](#)

Using the CLI

Use the `oci rover node certificate-authority update-root-ca` command and required parameters to update certificate details of a for a Roving Edge Infrastructure device node:

```
oci rover node certificate-authority update-root-ca --certificate-authority-id certificate_authority_ocid --rover-node-id rover_node_ocid [OPTIONS]
```

Refer to your Roving Edge Infrastructure device's CLI help for a list of parameters available for this command. See [Accessing Command Line Interface Help](#) on page 53.

For set up information regarding CLIs on your Roving Edge Infrastructure device, see [Using the Command Line Interface](#).

Renewing a Certificate for a Roving Edge Infrastructure Device Node while Connected

Describes how to renew an existing certificate for a device node while connected to the Oracle Cloud Infrastructure Cloud.

Renew the certificate for a device node if you want to extend its validity time, but do not want to change any of its details, such as the key algorithm. If you do want to change the details of the certificate, you must create a new one instead of renewing the existing certificate. See [Creating a certificate while connected](#).

Note:

If you want to renew a certificate for a disconnected device node, see [Creating a Certificate while Disconnected](#)

Using the Device Console

1. Access the Device Console for the device node whose certificate you are renewing.
2. Open the navigation menu and click **Node Management > Certificates**. The **Certificates** page appears. Each Roving Edge Infrastructure device node's certificate is listed.
3. Click **Renew certificates**. You can also click **Renew** under the **Action** menu at the right of the certificate entry. The **Renew certificates** dialog box appears.
4. Click **Not Valid After**. The date and time calendar appears. Select the date and UTC time wanted as the expiration date for the certificate, and then click **Submit**. The date and time you specify cannot exceed the maximum validity period of the certificate authority that is used for the certificate.

Each affected device node's certificate is now valid through the day and date you specified.

Renewing a Certificate for a Roving Edge Infrastructure Device Node while Disconnected

Describes how to renew an existing certificate for a device node while disconnected from the Oracle Cloud Infrastructure Cloud.

Renew the certificate for a device node if you want to extend its validity time, but do not want to change any of its details, such as the key algorithm. If you do want to change the details of the certificate, you must create a new one instead of renewing the existing certificate. See [Creating a certificate while disconnected](#).

Using the Device Console and OCI Cloud Console

1. Access the Device Console for the device node for which you are creating the certificate.
2. Open the navigation menu and click **Node Management > Certificates**. The **Certificates** page appears. Each Roving Edge Infrastructure device node's certificate is listed with its certificate details.
3. Click **Create Certificate Signing Requests**. You can also click **Create Certificate Signing Request** under the **Action** menu (three dots to the right of the node). The **Create Certificate Signing Request** dialog box appears.
4. Select a **Key Algorithm** from the list to be used for the certificate signing request.
5. Click **Submit**. The Device Console displays a message confirming that the certificate signing request for the device node has been successfully submitted.
6. Monitor the status of your certificate signing request by performing the following steps:
 - a. Click **Certificate Actions** under **Node Management** on the left side of the page to see the state of the request. The **Certificate Actions** page appears. The status of the certificate signing request is listed in tabular format. The page displays the last stage completed in the certificate signing request submission process.
 - b. Click **View** under the Actions menu (⋮) at the right of the certificate signing request entry to display the **View Certificate Action** dialog box. This dialog box displays a variety of information regarding the certificate request.
 - c. If your attempt to create a certificate fails for a particular device node, you can select **Retry** under the **Action** menu (three dots to the right of the node).
7. Click **Certificate** under **Node Management** to return to the **Certificate** page.
8. Click **View Certificate Signing Request** under the **Action** menu (three dots to the right of the node). The **View Certificate Signing Request** dialog box appears.

9. Download the certificate PEM file or copy and paste the certificate PEM contents into a file. Transfer this file to a computer that has access to the Oracle Cloud Infrastructure Cloud.
10. Access the Oracle Cloud Infrastructure Cloud Console and open the navigation menu. Under **Hybrid Cloud**, go to **Roving Edge Infrastructure > Nodes**. The **Nodes** page appears.
11. Click the device node for which you want to create a certificate. The device node's **Details** page appears.
12. Click the **Certificate Information** tab to view details on the device node's existing certificate. You can return to this tab later after you generate the new certificate to view the updated details.
13. Select **Renew Certificate** from the **More Actions** menu. The **Renew Certificate** dialog box appears.
14. Upload the certificate PEM file (.csr or .pem) from your connected computer, or copy and paste the certificate PEM contents into the **Certificate Signing Request** box.
15. Click **Not Valid After**. The date and time calendar appears. Select the date and UTC time wanted as the expiration date for the certificate, and then click **Submit**. The date and time you specify cannot exceed the maximum validity period of the certificate authority that is used for the certificate.
16. Click **Renew Certificate**. The **Details** page displays a message indicating that a renewed certificate has been generated with an associated OCID on the Oracle Cloud Infrastructure Cloud. The contents of the **Certificate Information** tab are also updated to reflect the renewed certificate.
17. Click **View Certificate Content**. The **View Certificate Content** dialog box appears.
18. Copy or download the certificate PEM file or contents to the computer that has connected access to the Roving Edge Infrastructure environment
19. Click **View CA Bundle Content** from the **More Actions** menu. The **View CA Bundle Content** dialog box appears.
20. Copy or download the CA bundle file or contents to the computer that has network connectivity to the Roving Edge Infrastructure device.

You can also use the CLI to perform the following tasks:

- Renewing a certificate for a Roving Edge Infrastructure device node. Run the following CLI command and parameters:

```
oci rover node certificate update --csr --rover-node-id rover_node_ocid certificate_signing_request --time-cert-validity-end time_cert_validity_end [OPTIONS]
```

certificate_signing_request is the certificate signing request in .PEM format. The maximum size of the request is 10240 characters.

time_cert_validity_end is the time when the renewed certificate's validity ends. You can express this time in the following formats:

- UTC with microseconds
- Timezone with microseconds
- Viewing a certificate for a Roving Edge Infrastructure device. Run the following CLI command and parameters:

```
oci rover node certificate get-leaf-certificate --rover-node-id rover_node_ocid
```

- View the CA bundle content of a Roving Edge Infrastructure. Run the following CLI command and parameters:

```
oci rover node ca-bundle get --rover-node-id rover_node_ocid
```

21. Return to the Device Console on the device node for which you are creating the certificate and access the **Certificates** page.
22. Select **Import** under the **Action** menu (three dots to the right of the node). The **Import Certificate** dialog box appears.

23. Upload the certificate file (.pem) from your connected computer, or copy and paste the certificate contents into the **Add Certificate** box.
24. Upload the CA bundle file (.pem) from your connected computer, or copy and paste the CA bundle contents into the **Add Ca-bundle** box.
25. Click **Import**. The **Certificates** page displays a message indicating that your request to import the certificate has been successfully submitted.
26. Monitor the status of your import by performing the following steps:
 - a. Click **Certificate Actions** under **Node Management** on the left side of the page to see the state of the import. The **Certificate Actions** page appears. The status of the import is listed in tabular format. The page displays the last stage completed in the import process.
 - b. Click **View** under the **Action** menu (three dots at the right of the import entry) to display the **View Certificate Action** dialog box. This dialog box displays a variety of information regarding the import.
 - c. If your attempt to import fails for a particular device node, you can select **Retry** under the **Action** menu (three dots to the right of the device node).

The device node's certificate and CA bundle are updated with the new ones you imported. Click **View** under the **Actions** menu to display the **View Certificates** dialog box and inspect the certificate and CA bundle.

Creating a Certificate for a Roving Edge Infrastructure Device while Connected

Describes how to create a new certificate for a Roving Edge Infrastructure device node while connected to the Oracle Cloud Infrastructure Cloud.

Note:

If you want to create a certificate for a disconnected device node, see [Creating a Certificate while Disconnected](#)

Using the Device Console

1. Access the Device Console for the device node for which you are creating the certificate.
2. Open the navigation menu and click **Node Management > Certificates**. The **Certificates** page appears. Each Roving Edge Infrastructure device node's certificate is listed.
3. Click **Create Certificates**. You can also click **Create** under the Actions menu (⋮) (at the right of each certificate entry). The **Create Certificates** dialog box appears.
4. Click **Not Valid After**. The date and time calendar appears. Select the date and UTC time wanted as the expiration date for the certificate, and then click **Submit**. The date and time you specify cannot exceed the maximum validity period of the certificate authority that is used for the certificate.
5. Click **Submit**.

The Device Console displays a message confirming that the request to create certificates for the device node have been successfully submitted.

6. Click **Certificate Actions** under **Node Management** on the left side of the page to see the state of the request. The **Certificate Actions** page appears. Each device node certificate request is listed in tabular format. This page displays information regarding the certificate request, including the current action and lifecycle status.
7. Click **View** under the Actions menu (⋮) at the right of each certificate request entry to display the **View Certificate Action** dialog box. This dialog box displays a variety of information regarding the certificate request.
8. If your attempt to create a certificate fails for a particular device node, you can select **Retry** under the **Action** menu to the right of the node.

The new certificate you created replaces the previous certificate in the affected nodes.

Creating a Certificate for a Roving Edge Infrastructure Device while Disconnected

Describes how to create a new certificate for a Roving Edge Infrastructure device node while disconnected from the Oracle Cloud Infrastructure Cloud.

Using the Device Console and OCI Cloud Console

1. Access the Device Console for the device node for which you are creating the certificate.
2. Open the navigation menu and click **Node Management > Certificates**. The **Certificates** page appears. Each Roving Edge Infrastructure device node's certificate is listed.
3. Click the **Create Certificate Signing Requests** button above the list of certificates. You can also click **Create Certificate Signing Request** under the **Action** menu (three dots to the right of the node). The **Create Certificate Signing Request** dialog box appears.
4. Select a **Key Algorithm** from the list to be used for the certificate signing request.
5. Click **Submit**. The Device Console displays a message confirming that the certificate signing request for the device node has been successfully submitted.
6. Monitor the status of your certificate signing request by performing the following steps:
 - a. Click **Certificate Actions** under **Node Management** on the left side of the page to see the state of the request. The **Certificate Actions** page appears. The status of the certificate signing request is listed in tabular format. The page displays the last stage completed in the certificate signing request submission process.
 - b. Click **View** under the **Action** menu (three dots at the right of the certificate signing request entry) to display the **View Certificate Action** dialog box. This dialog box displays a variety of information regarding the certificate request.
 - c. If your attempt to create a certificate fails for a particular device node, you can select **Retry** under the **Action** menu (three dots to the right of the node).
7. Click **Certificate** under **Node Management** to return to the **Certificate** page.
8. Click **View Certificate Signing Request** under the **Action** menu (three dots to the right of the node). The **View Certificate Signing Request** dialog box appears.
9. Download the certificate PEM file (.csr or .pem) or copy and paste the certificate PEM contents into a file. Transfer this file to a computer that has access to the Oracle Cloud Infrastructure Cloud.
10. Access the Oracle Cloud Infrastructure Cloud Console and open the navigation menu. Under **Hybrid Cloud**, go to **Roving Edge Infrastructure > Nodes**. The **Nodes** page appears.
11. Click the device node for which you want to create a certificate. The device node's **Details** page appears.
12. Click the **Certificate Information** tab to view details on the device node's existing certificate. You can return to this tab later after you generate the new certificate to view the updated details.
13. Select **Generate Certificate** from the **More Actions** menu. The **Generate Certificate** dialog box appears.
14. Upload the certificate PEM file (.csr or .pem) from your connected computer, or copy and paste the certificate PEM contents into the **Certificate Signing Request** box.
15. Click **Not Valid After**. The date and time calendar appears. Select the date and UTC time wanted as the expiration date for the certificate, and then click **Submit**. The date and time you specify cannot exceed the maximum validity period of the certificate authority that is used for the certificate.
16. Click **Generate Certificate**. The **Details** page displays a message indicating that a new certificate has been generated with an associated OCID on the Oracle Cloud Infrastructure Cloud. The contents of the **Certificate Information** tab are also updated to reflect the new certificate.
17. Click **View Certificate Content**. The **View Certificate Content** dialog box appears.
18. Copy or download the certificate PEM file or contents to the computer that has connected access to the Roving Edge Infrastructure environment
19. Click **View CA Bundle Content** from the **More Actions** menu. The **View CA Bundle Content** dialog box appears.
20. Copy or download the CA bundle file or contents to the computer that has network connectivity to the Roving Edge Infrastructure device.

You can also use the CLI to perform the following tasks:

- Creating a certificate for a Roving Edge Infrastructure device node. Run the following CLI command and parameters:

```
oci rover node certificate create --csr --rover-node-id rover_node_ocid certificate_signing_request --time-cert-validity-end time_cert_validity_end [OPTIONS]
```

certificate_signing_request is the certificate signing request in .PEM format. The maximum size of the request is 10240 characters.

time_cert_validity_end is the time when the renewed certificate's validity ends. You can express this time in the following formats:

- UTC with microseconds
 - Timezone with microseconds
- Viewing a certificate for a Roving Edge Infrastructure device. Run the following CLI command and parameters:

```
oci rover node certificate get-leaf-certificate --rover-node-id rover_node_ocid
```

- View the CA bundle content of a Roving Edge Infrastructure. Run the following CLI command and parameters:

```
oci rover node ca-bundle get --rover-node-id rover_node_ocid
```

21. Return to the Device Console on the device node for which you are creating the certificate and access the **Certificates** page.
22. Select **Import** under the **Action** menu (three dots to the right of the node). The **Import Certificate** dialog box appears.
23. Upload the certificate file (.pem) from your connected computer, or copy and paste the certificate contents into the **Add Certificate** box.
24. Upload the CA bundle file (.pem) from your connected computer, or copy and paste the CA bundle contents into the **Add Ca-bundle** box.
25. Click **Import**. The **Certificates** page displays a message indicating that your request to import the certificate has been successfully submitted.
26. Monitor the status of your import by performing the following steps:
 - a. Click **Certificate Actions** under **Node Management** on the left side of the page to see the state of the import. The **Certificate Actions** page appears. The status of the import is listed in tabular format. The page displays the last stage completed in the import process.
 - b. Click **View** under the **Action** menu (three dots at the right of the import entry) to display the **View Certificate Action** dialog box. This dialog box displays a variety of information regarding the import.
 - c. If your attempt to import fails for a particular device node, you can select **Retry** under the **Action** menu (three dots to the right of the device node).

The device node's certificate and CA bundle are updated with the new ones you imported. Click **View** under the **Actions** menu to display the **View Certificates** dialog box and inspect the certificate and CA bundle.

Identity and Access Management (IAM)

Describes how to learn about managing Identity and Access Management (IAM) tasks on your Roving Edge Infrastructure devices.

This section describes the following Roving Edge Infrastructure on-device resources related to Identity and Access Management (IAM):

- [Users](#)
- [User Credentials](#)
- [User Groups](#)
- [User Lockout Policies](#)

Users

Describes how to learn about user management tasks, including creating, updating, and deleting users, on your Roving Edge Infrastructure devices.

You can perform the following user management tasks:

- [Creating Users](#)
- [Listing Users](#)
- [Getting Users](#)
- [Editing Users](#)
- [Updating User Capabilities](#)
- [Deleting Users](#)

See [Managing Users](#) in the Oracle Cloud Infrastructure documentation for more information on this feature.

Creating a User

Describes how to create a user on your Roving Edge Infrastructure device.

Using the Device Console

1. Open the navigation menu and select **Identity Management > Users**. The **Users** page appears. All users are listed in tabular form.
2. Click **Create User**. The **Create User** dialog box appears.
3. Enter the following:
 - **Name:** A unique name or email address for the user. The name must be unique across all users in your tenancy. You cannot change this value later. The name must meet the following requirements: No spaces. Only Basic Latin letters (ASCII), numerals, hyphens, periods, underscores, +, and @.
 - **Description:** This value could be the user's full name, a nickname, or other descriptive information. You can change this value later.
4. Click **Create**. The new user appears in the **User** page. Next, you must access a secret key from the new user's UI console OAuth 2.0 client credential and forward it to the intended user. This key is the user's login password for accessing the Device Console.
5. Click the user entry in the **User** page. The user's **Details** page appears.
6. Click **OAuth 2.0 Client Credentials** on the left side of the page. The **OAuth 2.0 Client Credentials** page appears. By default, only the UI-console-oauth-credential is present in the list of OAuth 2.0 client credentials for a newly created user.
7. Click **UI-console-oauth-credential**. The UI-console-oauth-credential's **Details** page appears.
8. Click **Regenerate Secret**. The **Regenerate OAuth 2.0 Client Credential** dialog box appears, displaying the new password for the user.
9. Copy the generated secret and store it for your records. You cannot display this secret key after the dialog box is closed.
10. Click **Close** to close the dialog box.
11. Forward the secret key to the intended user. This key acts as the initial password for the user. The user can reset their Device Console login password by repeating the steps to regenerate a secret key within their user account.

New users created through the Device Console are automatically assigned to the default Administrators group. Now you need to give the user the credentials they need. See [User Credentials](#) on page 172.

Using the CLI

Use the `oci iam user create` command and required parameters to create a user on your Roving Edge Infrastructure devices:

```
oci iam user create --name name --description description [OPTIONS]
```

Refer to your Roving Edge Infrastructure device's CLI help for a list of parameters available for this command. See [Accessing Command Line Interface Help](#) on page 53.

For set up information regarding CLIs on your Roving Edge Infrastructure device, see [Using the Command Line Interface](#).

Using the API

Run the `CreateUser` operation to create a user on your Roving Edge Infrastructure devices.

Listing Users

Describes how to list the users on your Roving Edge Infrastructure device.

Using the Device Console

Open the navigation menu and select **Identity Management > Users**. The **Users** page appears. All users are listed in tabular form.

Using the CLI

Use the `oci iam user list` command required parameters to list the users on your Roving Edge Infrastructure devices:

```
oci iam user list [OPTIONS]
```

Refer to your Roving Edge Infrastructure device's CLI help for a list of parameters available for this command. See [Accessing Command Line Interface Help](#) on page 53.

For set up information regarding CLIs on your Roving Edge Infrastructure device, see [Using the Command Line Interface](#).

Using the API

Run the `ListUsers` operation to list the users on your Roving Edge Infrastructure devices.

Getting a User's Details

Describes how to get the details of a user on your Roving Edge Infrastructure device.

Using the Device Console

1. Open the navigation menu and select **Identity Management > Users**. The **Users** page appears. All users are listed in tabular form.
2. Click the user whose details you want to get. The user's **Details** page appears.

Using the CLI

Use the `oci iam user get` command and required parameters to get the details of a user on your Roving Edge Infrastructure devices:

```
oci iam user get --user-id user_ociid [OPTIONS]
```

Refer to your Roving Edge Infrastructure device's CLI help for a list of parameters available for this command. See [Accessing Command Line Interface Help](#) on page 53.

For set up information regarding CLIs on your Roving Edge Infrastructure device, see [Using the Command Line Interface](#).

Using the API

Run the `GetUser` operation to get the details of a user on your Roving Edge Infrastructure devices.

Editing a User

Describes how to edit a user on your Roving Edge Infrastructure device.

Using the Device Console

1. Open the navigation menu and select **Identity Management > Users**. The **Users** page appears. All users are listed in tabular form.
2. Click the user whose details you want to get. The user's **Details** page appears.
3. Click **Edit User**. The **Edit User** dialog box appears.
4. Make your edits. See [Creating a User](#) for descriptions of the settings.
5. Click **Save Changes**.

Using the CLI

Use the `oci iam user update` command and required parameters to edit a user on your Roving Edge Infrastructure devices:

```
oci iam user update --user-id user_ocid [OPTIONS]
```

Refer to your Roving Edge Infrastructure device's CLI help for a list of parameters available for this command. See [Accessing Command Line Interface Help](#) on page 53.

For set up information regarding CLIs on your Roving Edge Infrastructure device, see [Using the Command Line Interface](#).

Using the API

Run the `UpdateUser` operation to edit a user on your Roving Edge Infrastructure devices.

Updating a User's Capabilities

Describes how to update the capabilities of a user on your Roving Edge Infrastructure device.

You can make updates to the following user capabilities:

- API signing keys
- Auth token
- Customer secret keys
- OAuth 2.0 client credentials
- Local password
- SMTP credentials

See [About User Capabilities](#) in the Oracle Cloud Infrastructure documentation for more information on this feature.

Using the Device Console

1. Open the navigation menu and select **Identity Management > Users**. The **Users** page appears. All users are listed in tabular form.
2. Click the user whose details you want to get. The user's **Details** page appears.
3. Click **Edit User Capabilities**. The **Edit User Capabilities** dialog box appears.
4. Update any of the following capabilities:
 - API Keys
 - Auth Token
 - Customer Secret Keys
 - OAuth 2.0 Client Credentials
 - Local password
 - SMTP credentials
5. Click **Save Changes**.

Using the CLI

Use the `oci iam user update-user-capabilities` command and required parameters to update the capabilities of a user on your Roving Edge Infrastructure devices:

```
oci iam user update-user-capabilities --user-id user_ocid [OPTIONS]
```

Refer to your Roving Edge Infrastructure device's CLI help for a list of parameters available for this command. See [Accessing Command Line Interface Help](#) on page 53.

For set up information regarding CLIs on your Roving Edge Infrastructure device, see [Using the Command Line Interface](#).

Using the API

Run the `UpdateUserCapabilities` operation to update the capabilities of a user on your Roving Edge Infrastructure devices.

Deleting a User

Describes how to delete a user from your Roving Edge Infrastructure device.

Note:

Deleting all users causes you to be permanently locked out of the Roving Edge Infrastructure device.

Using the Device Console

1. Open the navigation menu and select **Identity Management > Users**. The **Users** page appears. All users are listed in tabular form.
2. Click the user you want to delete. The user's **Details** page appears.
3. Click **Delete**.
4. Confirm the deletion when prompted.

Using the CLI

Use the `oci iam user delete` command and required parameters to delete a user from your Roving Edge Infrastructure devices:

```
oci iam user delete --user-id user_ocid [OPTIONS]
```

Refer to your Roving Edge Infrastructure device's CLI help for a list of parameters available for this command. See [Accessing Command Line Interface Help](#) on page 53.

For set up information regarding CLIs on your Roving Edge Infrastructure device, see [Using the Command Line Interface](#).

Using the API

Run the `DeleteUser` operation to delete a user from your Roving Edge Infrastructure devices.

User Credentials

Describes how to manage user credential tasks on your Roving Edge Infrastructure devices.

See [Managing User Credentials](#) in the Oracle Cloud Infrastructure documentation for more information on this feature.

This section describes the following user credential types:

- [Auth Tokens](#)
- [API Signing Keys](#)
- [OAuth 2.0 Client Credentials](#)
- [Customer Secret Keys](#)

Auth Tokens

Describes how to manage auth token credential tasks for users on your Roving Edge Infrastructure devices.

You can perform the following auth token management tasks:

- [Creating Auth Tokens](#)
- [Listing Auth Tokens](#)
- [Deleting Auth Tokens](#)

See [Working with Auth Tokens](#) in the Oracle Cloud Infrastructure documentation for more information on this feature.

You need the following information from the OAuth 2.0 client credential "UI-console-oauth-credential" that was generated when the user resource was created:

- The generated secret
- The OCID of the OAuth 2.0 client credential
- The scope and audience (fully qualified scope)

See [OAuth 2.0 Client Credentials](#) on page 176.

Creating Auth Tokens

Describes how to create an auth token credential for a user on your Roving Edge Infrastructure device.

If you are an administrator creating an auth token for another user, you need to securely deliver it to the user by providing it verbally, printing it out, or sending it through a secure email service.

Using the Device Console

1. Open the navigation menu and select **Identity Management > Users**. The **Users** page appears. All users are listed in tabular form.
2. Click the user for which you want to create an auth token. The user's **Details** page appears.
3. Click **Auth Tokens** under **Resources**. The **Auth Tokens** page appears. All auth tokens are listed in tabular form.
4. Click **Generate Token**. The **Generate Token** dialog box appears.
5. Enter a **Description** that indicates what this token is for, for example, "Swift password token."
6. Click **Generate Token**. The new token string is displayed.
7. Copy the token string immediately, because you cannot retrieve it again after closing the **Generate Token** dialog box.

Using the CLI

Use the `oci iam auth-token create` command and required parameters to create an auth token credential for a user on your Roving Edge Infrastructure devices:

```
oci iam auth-token create --user-id user_ocid --description description
[OPTIONS]
```

Refer to your Roving Edge Infrastructure device's CLI help for a list of parameters available for this command. See [Accessing Command Line Interface Help](#) on page 53.

For set up information regarding CLIs on your Roving Edge Infrastructure device, see [Using the Command Line Interface](#).

Using the API

Run the `CreateAuthToken` operation to create an auth token credential for a user on your Roving Edge Infrastructure devices.

Listing Auth Tokens

Describes how to list the auth token credentials for a user on your Roving Edge Infrastructure device.

Using the Device Console

1. Open the navigation menu and select **Identity Management > Users**. The **Users** page appears. All users are listed in tabular form.
2. Click the user for which you want to create an auth token. The user's **Details** page appears.
3. Click **Auth Tokens** under **Resources**. The **Auth Tokens** page appears. All auth tokens are listed in tabular form.

Using the CLI

Use the `oci iam auth-token list` command and required parameters to list the auth token credentials for a user on your Roving Edge Infrastructure devices:

```
oci iam auth-token list --user-id user-id [OPTIONS]
```

Refer to your Roving Edge Infrastructure device's CLI help for a list of parameters available for this command. See [Accessing Command Line Interface Help](#) on page 53.

For set up information regarding CLIs on your Roving Edge Infrastructure device, see [Using the Command Line Interface](#).

Using the API

Run the `ListAuthTokens` operation to display a list of auth tokens using the API.

Deleting Auth Tokens

Describes how to delete an auth token credential from a user on your Roving Edge Infrastructure device.

Note:

Deleting an auth token makes it no longer valid for accessing third-party APIs.

Using the Device Console

1. Open the navigation menu and select **Identity Management > Users**. The **Users** page appears. All users are listed in tabular form.
2. Click the user for which you want to create an auth token. The user's **Details** page appears.
3. Click **Auth Tokens** under **Resources**. The **Auth Tokens** page appears. All auth tokens are listed in tabular form.
4. Select the Actions menu (⋮) for the auth token you want to delete and click **Delete**.
5. Confirm the deletion when prompted.

Using the CLI

Use the `oci iam auth-token delete` command and required parameters to delete an auth token credential from a user on your Roving Edge Infrastructure devices:

```
oci iam auth-token delete --user-id user_ocid --auth-token-id auth_token_ocid [OPTIONS]
```

Refer to your Roving Edge Infrastructure device's CLI help for a list of parameters available for this command. See [Accessing Command Line Interface Help](#) on page 53.

For set up information regarding CLIs on your Roving Edge Infrastructure device, see [Using the Command Line Interface](#).

Using the API

Run the `DeleteAuthToken` operation to delete an auth token credential from a user on your Roving Edge Infrastructure devices.

API Signing Keys

Describes how to manage API signing key credential tasks for users on your Roving Edge Infrastructure devices.

You can perform the following API signing keys management tasks:

- [Uploading API Signing Keys](#)
- [Listing API Signing Keys](#)
- [Deleting API Signing Keys](#)

See [Working with Console Passwords and API Keys](#) in the Oracle Cloud Infrastructure documentation for more information on this feature.

Uploading an API Signing Key

Describes how to create an API signing key credential for a user on your Roving Edge Infrastructure device.

Using the Device Console

1. Open the navigation menu and select **Identity Management > Users**. The **Users** page appears. All users are listed in tabular form.
2. Click the user for which you want to create an auth token. The user's **Details** page appears.
3. Click **API Keys** under **Resources**. The **API Keys** page appears. All API keys are listed in tabular form.
4. Click **Add Public Key**. The **Add Public Key** dialog box appears.
5. Select one of the following options:
 - **Choose Public Key File:** Drag and drop a key file into the **Public Key** box or click **select one** to navigate to a location in your network where you can select a key file.

Note:

All public key files must have the `.pem` extension.

- **Paste Public Keys:** Copy and paste the public key into the **Public Key** box.
6. Click **Add**.
 7. View the user's **Details** page to confirm the uploading.
 8. For the API key you want to delete, click **Edit**.
 9. Make your changes and click **Save**.

Using the CLI

Use the `oci iam user api-key upload` command and required parameters to create an API signing key credential for a user on your Roving Edge Infrastructure devices:

```
oci iam user api-key upload --user-id user_ocid [OPTIONS]
```

Refer to your Roving Edge Infrastructure device's CLI help for a list of parameters available for this command. See [Accessing Command Line Interface Help](#) on page 53.

For set up information regarding CLIs on your Roving Edge Infrastructure device, see [Using the Command Line Interface](#).

Using the API

Run the `UploadApiKey` operation to create an API signing key credential for a user on your Roving Edge Infrastructure devices.

Listing API Signing Keys

Describes how to list the API signing key credentials for a user on your Roving Edge Infrastructure device.

Using the Device Console

1. Open the navigation menu and select **Identity Management > Users**. The **Users** page appears. All users are listed in tabular form.
2. Click the user for which you want to create an API key. The user's **Details** page appears.
3. Click **API Keys** under **Resources**. The **API Keys** page appears. All API keys are listed in tabular form.

Using the CLI

Use the `oci iam user api-key list` command and required parameters to list the API signing key credentials for a user on your Roving Edge Infrastructure devices:

```
oci iam user api-key list --user-id user_ocid [OPTIONS]
```

Refer to your Roving Edge Infrastructure device's CLI help for a list of parameters available for this command. See [Accessing Command Line Interface Help](#) on page 53.

For set up information regarding CLIs on your Roving Edge Infrastructure device, see [Using the Command Line Interface](#).

Using the API

Run the `ListApiKeys` operation to list the API signing key credentials for a user on your Roving Edge Infrastructure devices.

Deleting API Signing Keys

Describes how to delete an API signing key credential from a user on your Roving Edge Infrastructure device.

Using the Device Console

1. Open the navigation menu and select **Identity Management > Users**. The **Users** page appears. All users are listed in tabular form.
2. Click the user for which you want to create an auth token. The user's **Details** page appears.
3. Click **API Keys** under **Resources**. The **AOI Keys** page appears. All API keys are listed in tabular form.
4. Select the Actions menu (⋮) for the API key you want to delete and click **Delete**.
5. Confirm the deletion when prompted.

Using the CLI

Use the `oci iam user api-key delete` command and required parameters to delete an API signing key credential from a user on your Roving Edge Infrastructure devices:

```
oci iam user api-key delete --user-id user_ocid --fingerprint fingerprint [OPTIONS]
```

Refer to your Roving Edge Infrastructure device's CLI help for a list of parameters available for this command. See [Accessing Command Line Interface Help](#) on page 53.

For set up information regarding CLIs on your Roving Edge Infrastructure device, see [Using the Command Line Interface](#).

Using the API

Run the `DeleteApiKey` operation to delete an API signing key credential from a user on your Roving Edge Infrastructure devices.

OAuth 2.0 Client Credentials

Describes how to manage OAuth 2.0 client credential tasks for users on your Roving Edge Infrastructure devices.

You can perform the following OAuth 2.0 client credentials management tasks:

- [Listing OAuth 2.0 Client Credentials for a Roving Edge Infrastructure Device](#) on page 177
- [Getting an OAuth 2.0 Client Credential's Details](#) on page 177

The single default OAuth 2.0 client credential "UI-console-oauth-credential" is generated when a user is added. This client credential is required for the user to login to a Device Console.

You can view this entry in the list of OAuth 2.0 client credentials under the within the Details page of a user resource and view its details. You cannot update or delete this credential, nor can you create additional ones for the user.

You need the following information from the OAuth 2.0 client credential for the token request:

- The generated secret
- The OCID of the OAuth 2.0 client credential
- The scope and audience (fully-qualified scope)

See [Working with OAuth 2.0 Client Credentials](#) in the Oracle Cloud Infrastructure documentation for more information on this feature.

Listing OAuth 2.0 Client Credentials for a Roving Edge Infrastructure Device

Describes how to list of the OAuth 2.0 client credentials for a user on your Roving Edge Infrastructure devices.

The single default OAuth 2.0 client credential "UI-console-oauth-credential" is generated when a user is added. This OAuth 2.0 client credential is the only one allowed for a user.

Using the Device Console

1. Open the navigation menu and select **Identity Management > Users**. The **Users** page appears. All users are listed in tabular form.
2. Click the user whose OAuth 2.0 client credentials you want to list. The user's **Details** page appears.
3. Click **OAuth 2.0 Client Credentials** under **Resources**. The **OAuth 2.0 Client Credentials** page appears. All OAuth 2.0 client credentials are listed in tabular form.

Using the CLI

Use the `oci iam user oauth2-credential list` command and required parameters to list of the OAuth 2.0 client credentials for a user on your Roving Edge Infrastructure devices:

```
oci iam user oauth2-credential list --user-id user_ocid [OPTIONS]
```

Refer to your Roving Edge Infrastructure device's CLI help for a list of parameters available for this command. See [Accessing Command Line Interface Help](#) on page 53.

For set up information regarding CLIs on your Roving Edge Infrastructure device, see [Using the Command Line Interface](#).

Using the API

Run the `ListOAuthClientCredentials` operation to display a list of OAuth user tokens.

Getting an OAuth 2.0 Client Credential's Details

Describes how to get the details of an OAuth 2.0 client credential for a user on your Roving Edge Infrastructure device.

Using the Device Console

1. Open the navigation menu and select **Identity Management > Users**. The **Users** page appears. All users are listed in tabular form.
2. Click the user for which you want to get OAuth 2.0 client credential details. The user's **Details** page appears.
3. Click **OAuth 2.0 Client Credentials** under **Resources**. The **OAuth 2.0 Client Credentials** page appears. All OAuth 2.0 Client Credentials are listed in tabular form.
4. Click the OAuth 2.0 client credential whose details you want to get. The OAuth 2.0 client credential's **Details** page appears.

Regenerating OAuth 2.0 Client Credential Secrets for Password Resetting

Describes how to regenerate the secret of an OAuth 2.0 Client Credential resource associated with a user on your Roving Edge Infrastructure device.

Note:

Regenerating the secret and forwarded to the user in need is a requirement for resetting a user's password.

Using the Device Console

1. Open the navigation menu and select **Identity Management > Users**. The **Users** page appears. All users are listed in tabular form.
2. Select the user whose secret you want to regenerate. The user's **Details** page appears.
3. Click **OAuth 2.0 Client Credentials** under **Resources**. The OAuth 2.0 client credential's page appears. All OAuth 2.0 client credentials are listed in tabular form.
4. Click **Regenerate Secret** under **UI-console-oauth-credential**. The **Regenerate OAuth 2.0 Client Credential** dialog box appears.
5. Click **Regenerate Secret**.

Note:

If you generate a new secret for this OAuth 2.0 client credential, the previously generated secret becomes invalid and requests made with the previous secret are denied access to target scopes.

6. Copy or otherwise record the regenerated secret and securely transmit the new secret to the user with the lost password. The regenerated secret is their new password. Ensure that the user regenerates their own password using these steps after they regain access to the Device Console.

Customer Secret Keys

Learn about customer secret key management tasks for users on your Roving Edge Infrastructure device.

You can perform the following customer secret keys management tasks:

- [Creating Customer Secret Keys](#)
- [Listing Customer Secret Keys](#)
- [Editing Customer Secret Keys](#)
- [Deleting Customer Secret Keys](#)

A customer secret key consists of an access key/secret key pair. Oracle automatically generates the access key when you or your administrator generates the secret key to create the customer secret key.

See [Working with Customer Secret Keys](#) in the Oracle Cloud Infrastructure documentation for more information on this feature.

Creating a Customer Secret Key

Describes how to create a customer secret key for a user on your Roving Edge Infrastructure device.

Using the Device Console

1. Open the navigation menu and select **Identity Management > Users**. The **Users** page appears. All users are listed in tabular form.
2. Click the user for whom you want to create a customer secret key. The user's **Details** page appears.
3. Click **Customer Secret Keys** under **Resources**. The **Customer Secret Keys** page appears. All customer secret keys are listed in tabular form.
4. Click **Generate Secret Key**. The **Generate Secret Key** dialog box appears.
5. Enter a name for the secret key.
6. Click **Generate Secret Key**.

The generated **Secret Key** is displayed in the **Generate Secret Key** dialog box. At the same time, Oracle generates the **Access Key** that is paired with the **Secret Key**. The newly generated Customer Secret key is added to the list of **Customer Secret Keys**.

7. Copy the **Secret Key** immediately, because you cannot retrieve the **Secret Key** again after closing the dialog box for security reasons. If you are an administrator creating a customer secret key for another user, you need to securely deliver it to the user by providing it verbally, printing it out, or sending it through a secure email service.
8. Click **Close**.
9. To show or copy the **Access Key**, click the **Show** or **Copy** action to the left of the **Name** of a particular customer secret key.

Using the CLI

Use the `oci iam customer-secret-key create` command and required parameters to create a customer secret key for a user on your Roving Edge Infrastructure devices:

```
oci iam customer-secret-key create --user-id user_ocid --display-name display_name [OPTIONS]
```

Refer to your Roving Edge Infrastructure device's CLI help for a list of parameters available for this command. See [Accessing Command Line Interface Help](#) on page 53.

For set up information regarding CLIs on your Roving Edge Infrastructure device, see [Using the Command Line Interface](#).

Using the API

Run the `CreateCustomerSecretKey` operation to create a customer secret key for a user on your Roving Edge Infrastructure devices.

Listing Customer Secret Keys for a Roving Edge Infrastructure Device

Describes how to list the customer secret keys for a user on your Roving Edge Infrastructure device.

Using the Device Console

1. Open the navigation menu and select **Identity Management > Users**. The **Users** page appears. All users are listed in tabular form.
2. Click the user whose customer secret keys you want to list. The user's **Details** page appears.
3. Click **Customer Secret Keys** under **Resources**. The **Customer Secret Keys** page appears. All customer secret keys are listed in tabular form.

Using the CLI

Use the `oci iam customer-secret-key list` command and required parameters to list the customer secret keys for a user on your Roving Edge Infrastructure devices:

```
oci iam customer-secret-key list --user-id user_ocid [OPTIONS]
```

Refer to your Roving Edge Infrastructure device's CLI help for a list of parameters available for this command. See [Accessing Command Line Interface Help](#) on page 53.

For set up information regarding CLIs on your Roving Edge Infrastructure device, see [Using the Command Line Interface](#).

Using the API

Run the `ListCustomerSecretKeys` operation to create a customer secret key for a user on your Roving Edge Infrastructure devices.

Editing a Customer Secret Key for a Roving Edge Infrastructure Device

Describes how to edit a customer secret key for a user on your Roving Edge Infrastructure device.

Using the Device Console

1. Open the navigation menu and select **Identity Management > Users**. The **Users** page appears. All users are listed in tabular form.
2. Click the user whose customer secret key you want to edit. The user's **Details** page appears.
3. Click **Customer Secret Keys** under **Resources**. The **Customer Secret Keys** page appears. All customer secret keys are listed in tabular form.
4. Click the secret key you want to edit. The **Customer Secret Key** dialog box appears.
5. Click **Edit**. The **Edit Customer Secret Key** dialog box appears.
6. Make your edits. See [Creating a Customer Secret Key](#) for descriptions of the settings.
7. Click **Save**.

Using the CLI

Use the `oci iam customer-secret-key update` command and required parameters to edit a customer secret key for a user on your Roving Edge Infrastructure devices:

```
oci iam customer-secret-key update --user-id user_ocid --customer-secret-key-id customer_secret_key_ocid [OPTIONS]
```

Refer to your Roving Edge Infrastructure device's CLI help for a list of parameters available for this command. See [Accessing Command Line Interface Help](#) on page 53.

For set up information regarding CLIs on your Roving Edge Infrastructure device, see [Using the Command Line Interface](#).

Using the API

Run the `UpdateCustomerSecretKey` operation to edit a customer secret key for a user on your Roving Edge Infrastructure devices.

Deleting a Customer Secret Key from a Roving Edge Infrastructure Device

Describes how to delete a customer secret key from a user on your Roving Edge Infrastructure device.

Using the Device Console

1. Open the navigation menu and select **Identity Management > Users**. The **Users** page appears. All users are listed in tabular form.
2. Click the user whose customer secret key you want to delete. The user's **Details** page appears.
3. Click **Customer Secret Keys** under **Resources**. The **Customer Secret Keys** page appears. All customer secret keys are listed in tabular form.
4. Click the secret key you want to delete. The **Customer Secret Key** dialog box appears.
5. Click **Delete**.
6. Confirm the deletion when prompted.

Using the CLI

Use the `oci iam customer-secret-key delete` command and required parameters to delete a customer secret key from a user on your Roving Edge Infrastructure devices:

```
oci iam customer-secret-key delete --user-id user_ocid --customer-secret-key-id customer_secret_key_ocid [OPTIONS]
```

Refer to your Roving Edge Infrastructure device's CLI help for a list of parameters available for this command. See [Accessing Command Line Interface Help](#) on page 53.

For set up information regarding CLIs on your Roving Edge Infrastructure device, see [Using the Command Line Interface](#).

Using the API

Run the `DeleteCustomerSecretKey` operation to delete a customer secret key from a user on your Roving Edge Infrastructure devices.

User Groups

Describes how to learn about user group management tasks, including creating, updating, and deleting user groups, on your Roving Edge Infrastructure devices.

See [Managing Groups](#) in the Oracle Cloud Infrastructure documentation for more information on this feature.

You can perform the following user group management tasks:

- [Creating a User Group](#)
- [Listing the User Groups](#)
- [Getting a User Group's Details](#)

- [Editing a User Group](#)
- [Listing the Users in a User Group](#)
- [Adding a User to a User Group](#)
- [Removing a User from a User Group](#)
- [Deleting a User Group](#)

Creating a User Group

Describes how to get the details of a user group on your Roving Edge Infrastructure device.

Using the Device Console

1. Open the navigation menu and select **Identity Management > Groups**. The **Groups** page appears. All user groups are listed in tabular form.
2. Click **Create Group**. The **Create Group** dialog box appears.
3. Complete the following:
 - **Name:** Enter a unique name for the user group. The name must be unique across all users in your tenancy. You cannot change this value later. The name must meet the following requirements: No spaces. Only Basic Latin letters (ASCII), numerals, hyphens, periods, underscores, +, and @.
 - **Description:** Enter a description for the user group. You can change this value later.
4. Click **Create**. The user group appears in the **Groups** page.

Using the CLI

Use the [oci iam group create](#) command and required parameters to create a user group on your Roving Edge Infrastructure devices:

```
oci iam group create --name name --description description [OPTIONS]
```

Refer to your Roving Edge Infrastructure device's CLI help for a list of parameters available for this command. See [Accessing Command Line Interface Help](#) on page 53.

For set up information regarding CLIs on your Roving Edge Infrastructure device, see [Using the Command Line Interface](#).

Using the API

Run the [CreateGroup](#) operation to create a user group on your Roving Edge Infrastructure devices.

Listing User Groups

Describes how to list the user groups on your Roving Edge Infrastructure device.

Using the Device Console

1. Open the navigation menu and select **Identity Management > Groups**. The **Groups** page appears. All user groups are listed in tabular form.

Using the CLI

Use the [oci iam group list](#) command and required parameters to list the user groups on your Roving Edge Infrastructure devices:

```
oci iam group list [OPTIONS]
```

Refer to your Roving Edge Infrastructure device's CLI help for a list of parameters available for this command. See [Accessing Command Line Interface Help](#) on page 53.

For set up information regarding CLIs on your Roving Edge Infrastructure device, see [Using the Command Line Interface](#).

Using the API

Run the [ListGroup](#)s operation to list the user groups on your Roving Edge Infrastructure devices.

Getting a User Group's Details for a Roving Edge Infrastructure Device

Describes how to get the details of a user group on your Roving Edge Infrastructure device.

Using the Device Console

1. Open the navigation menu and select **Identity Management > Groups**. The **Groups** page appears. All user groups are listed in tabular form.
2. Click the user group whose details that you want to get. The user group's **Details** page appears.

Using the CLI

Use the `oci iam group get` command and required parameters to get the details user group on your Roving Edge Infrastructure devices:

```
oci iam group get --group-id group_ocid [OPTIONS]
```

Refer to your Roving Edge Infrastructure device's CLI help for a list of parameters available for this command. See [Accessing Command Line Interface Help](#) on page 53.

For set up information regarding CLIs on your Roving Edge Infrastructure device, see [Using the Command Line Interface](#).

Using the API

Run the `GetGroup` operation to get the details of a group on your Roving Edge Infrastructure devices.

Editing a User Group for a Roving Edge Infrastructure Device

Describes how to edit a user group on your Roving Edge Infrastructure device.

Using the Device Console

1. Open the navigation menu and select **Identity Management > Groups**. The **Groups** page appears. All user groups are listed in tabular form.
2. Click the user group that you want to edit. The user group's **Details** dialog box appears.
3. Click **Edit Group**. The **Edit Group** dialog box appears.
4. Make your edits. See [Creating a User Group](#) for descriptions of the settings.
5. Click **Save**.

Using the CLI

Use the `oci iam group update` command and required parameters to edit a user group on your Roving Edge Infrastructure devices:

```
oci iam group update --group-id group_ocid [OPTIONS]
```

For a complete list of flags and variable options for CLI commands, see the [Command Line Reference](#).

For set up information regarding CLIs on your Roving Edge Infrastructure device, see [Using the Command Line Interface](#).

Using the API

Run the `UpdateGroup` operation to edit a user group on your Roving Edge Infrastructure devices.

Listing Users in a User Group for a Roving Edge Infrastructure Device

Describes how to list the users in a user group on your Roving Edge Infrastructure device.

Using the Device Console

1. Open the navigation menu and select **Identity Management > Groups**. The **Groups** page appears. All user groups are listed in tabular form.
2. Click **Groups**. The **Groups** page appears. All groups are listed in tabular form.
3. Click the user group whose users you want to list. The user group's **Details** page appears. All members of the user group are listed in tabular form.

Using the CLI

Use the `oci iam group list-users` command and required parameters to list the users in a user group on your Roving Edge Infrastructure devices:

```
oci iam group list-users --group-id group_ocid [OPTIONS]
```

Refer to your Roving Edge Infrastructure device's CLI help for a list of parameters available for this command. See [Accessing Command Line Interface Help](#) on page 53.

For set up information regarding CLIs on your Roving Edge Infrastructure device, see [Using the Command Line Interface](#).

Using the API

Run the `ListUserGroupMemberships` operation to list the users in a user group on your Roving Edge Infrastructure devices.

Adding a User to a User Group

Describes how to add a user to a user group on your Roving Edge Infrastructure device.

Using the Device Console

1. Open the navigation menu and select **Identity Management > Groups**. The **Groups** page appears. All user groups are listed in tabular form.
2. Click the user group whose details that you want to get. The user group's **Details** dialog box appears.
3. Click **Group Members** under the left-side navigation. All the members in the group are listed in tabular form.
4. Click **Add User to Group** under **Group Members**. The **Add User to Group** dialog box appears.
5. Select a user from the **Users** list and click **Add**. The **Group Members** list reappears listing the user you just added.
6. Add any other users to the group using the same method.

Using the CLI

Use the `oci iam group add-user` command and required parameters to add a user to a user group on your Roving Edge Infrastructure devices:

```
oci iam group add-user --user-id user_ocid --group-id group_ocid [OPTIONS]
```

Refer to your Roving Edge Infrastructure device's CLI help for a list of parameters available for this command. See [Accessing Command Line Interface Help](#) on page 53.

For set up information regarding CLIs on your Roving Edge Infrastructure device, see [Using the Command Line Interface](#).

Using the API

Run the `AddUserToGroup` operation to add a user to a user group on your Roving Edge Infrastructure devices.

Removing a User from a User Group

Describes how to remove a user from a user group on your Roving Edge Infrastructure device.

Using the Device Console

1. Open the navigation menu and select **Identity Management > Groups**. The **Groups** page appears. All user groups are listed in tabular form.
2. Click the user group whose member that you want to remove. The user group's **Details** page appears.
3. Click **Group Members** under the left-side navigation. All the members in the group are listed in tabular form.
4. Select the Actions menu (⋮) for the member that you want to remove and click **Remove Member from Group**.
5. Confirm the removal when prompted.

Using the CLI

Use the `oci iam group remove-user` command and required parameters to remove a user from a user group on your Roving Edge Infrastructure devices:

```
oci iam group remove-user --user-id user_ocid --group-id group_ocid
[OPTIONS]
```

Refer to your Roving Edge Infrastructure device's CLI help for a list of parameters available for this command. See [Accessing Command Line Interface Help](#) on page 53.

For set up information regarding CLIs on your Roving Edge Infrastructure device, see [Using the Command Line Interface](#).

Using the API

Run the `RemoveUserFromGroup` operation to remove a user from a user group on your Roving Edge Infrastructure devices.

Deleting a User Group

Describes how to delete a user group from your Roving Edge Infrastructure device.

Note:

You cannot delete a user group that contains users. Delete all users in the group first before deleting the user group. See [Removing a User from a User Group](#) for more information.

Using the Device Console

1. Open the navigation menu and select **Identity Management > Groups**. The **Groups** page appears. All user groups are listed in tabular form.
2. Click the user group that you want to delete. The user group's **Details** dialog box appears.
3. Click **Delete**.
4. Confirm the deletion when prompted.

Using the CLI

Use the `oci iam group delete` command and required parameters to delete a user group from your Roving Edge Infrastructure devices:

```
oci iam group delete --group-id group_ocid [OPTIONS]
```

Refer to your Roving Edge Infrastructure device's CLI help for a list of parameters available for this command. See [Accessing Command Line Interface Help](#) on page 53.

For set up information regarding CLIs on your Roving Edge Infrastructure device, see [Using the Command Line Interface](#).

Using the API

Run the `DeleteGroup` operation to delete a user group from your Roving Edge Infrastructure devices.

Applying Lockout Policies to Roving Edge Infrastructure Device Users

Describes how to apply lockout policies to Roving Edge Infrastructure device users.

As an administrator, you can establish a lockout policy for Roving Edge Infrastructure users based on the number of failed login attempts, the amount of time since the previous login, or both. If these factors apply, the user is unable to log in without their account being reactivated by an administrator.

Using the Device Console

1. Open the navigation menu and select **Identity Management > Authentication Settings**. The **Authentication Settings** page appears.
2. Click **Edit Authentication Settings**. The **Edit Authentication Settings** dialog box appears.
3. Select either or both of the following options:
 - **Deactivate a user after 3 consecutive failed login attempts within a 15 minute window.**
 - **Deactivate a user if they have not logged in after 90 days.**
4. Click **Submit**.

Compute Virtual Machine Infrastructure

Describes the on-device services you can use to set up compute virtual machines within your Roving Edge Infrastructure environment.

This section describes the following tasks and Roving Edge Infrastructure on-device services related to compute virtual machine (VM) infrastructure:

- [Preserving Hosts File Edits for Roving Edge Infrastructure](#) on page 185
- [Updating DNS](#)
- [Adding cloud-init Information for Roving Edge Infrastructure](#) on page 186
- [Using Oracle Repositories on Linux Instances](#)
- [Running Command Line Utilities](#)
- [Instances](#)
- [Configuring Multiple VNICs for Roving Edge Infrastructure Devices](#) on page 201
- [Custom Images](#)
- [Boot Volumes](#)
- [Console History Capture](#)

Note:

Do not allow your CPU usage to exceed 80%.

Preserving Hosts File Edits for Roving Edge Infrastructure

Preserve your edits to the `/etc/hosts` file on a compute instance on your Roving Edge Infrastructure device.

To preserve your edits to the `/etc/hosts` file on a compute instance in Roving Edge Infrastructure, open the following file:

```
/etc/oci-hostname.conf
```

Update the `PRESERVE_HOSTINFO` value at the bottom of the configuration from the default 0 to 2 or 3. For example:

```
# This configuration file controls the hostname persistence behavior for
# Oracle Linux
# compute instance on Oracle Cloud Infrastructure (formerly Baremetal Cloud
# Services)
# Set PRESERVE_HOSTINFO to one of the following values
# 0 -- default behavior to update hostname, /etc/hosts and /etc/
# resolv.conf to
#     reflect the hostname set during instance creation from the metadata
#     service
# 1 -- preserve user configured hostname across reboots; update /etc/hosts
#     and
#     /etc/resolv.conf from the metadata service
```

```
# 2 -- preserve user configured hostname across instance reboots; no
  custom
#      changes to /etc/hosts and /etc/resolv.conf from the metadata
  service,
#      but dhclient will still overwrite /etc/resolv.conf
# 3 -- preserve hostname and /etc/hosts entries across instance reboots;
#      update /etc/resolv.conf from instance metadata service
PRESERVE_HOSTINFO=2
```

Updating the `PRESERVE_HOSTINFO` value prevents the metadata service from overwriting the changes to the `/etc/hosts` file.

Updating DNS on Roving Edge Infrastructure Instances

Update the Domain Name Service (DNS) settings on your system to include the nameservers the instance can reach.

To preserve your edits to the `/etc/resolv.conf` file, run the following command:

```
chattr +i /etc/resolv.conf
```

Inclusion of the `+i` attribute in the command protects the `/etc/resolv.conf` file on Linux so that no one can modify it, not even the root user.

To remove the write protect attribute, run the following command:

```
chattr -i /etc/resolv.conf
```

Adding cloud-init Information for Roving Edge Infrastructure

Describes how to add cloud-init information for Roving Edge Infrastructure.

Use cloud-init to run customization scripts. See [Using Custom Cloud-init Initialization Scripts](#) for more information about using cloud-init in Oracle Cloud Infrastructure. Refer to the following [cloud-init documentation](#) for general information about cloud-init.

Scripts must have a shebang (`#!`) at the top.

You can run Roving Edge Infrastructure-provisioned customization scripts for easy provisioning of Compute instances.

Roving Edge Infrastructure users that are created using cloud-init-based customization scripts, and installed software packages are preserved.

To configure your Roving Edge Infrastructure Compute instance to use cloud-init:

1. Open the following file on your Roving Edge Infrastructure devices:

```
/etc/cloud/cloud.cfg
```

2. Add the following line under the `scripts-user` section:

```
[ scripts-user, always ]
```

3. Save and close the `/etc/cloud/cloud.cfg` file.
4. Place any cloud-init customization scripts in the following folder:

```
/var/lib/cloud/scripts/per-boot
```

These scripts run at every boot and overwrite dracut initrd configs as it runs after that process.

Using Oracle Repositories on Oracle Linux Instances for Roving Edge Infrastructure

Update an Oracle Linux instance's repository settings to work with Roving Edge Infrastructure.

If you are using an Oracle Linux image, change the repository settings to update the instance for Roving Edge Infrastructure:

1. Go to the following location:

```
/etc/yum/vars/
```

2. Remove the `ociregion` file from the directory.
3. Perform one of the following tasks:

- If you are using a proxy server, set the proxy in `/etc/yum.conf` file. For example:

```
proxy=http://www-proxy.us.oracle.com:80
```

- If you are using your own repo, update all repos in `/etc/yum/repos.d`.

Using Unbreakable Linux Network

Access to Unbreakable Linux Network (ULN), including Ksplice, is included with Roving Edge Infrastructure devices. Obtain the Customer Support Identifier (CSI) from your Roving Edge Infrastructure purchase contract. See [ULN Access for Oracle Cloud Infrastructure](#) for more information.

Running CLIs on Device-Hosted Compute Instances

Configure your Roving Edge Infrastructure device to run the command line interface (CLI) on its compute instances.

Follow these guidelines for running CLIs on compute instances hosted by Roving Edge Infrastructure devices.

Note:

The instructions in this topic are for Oracle Linux host computers.

- Have the VM go through the following local IP:
169.254.169.254
- Have the VM refer to the Roving Edge Infrastructure device as `otec-console-local`.
- Employ the following IP Tables rules:

```
{ for i in 19060 8019 12050 21060 22060 23060 22060 12060;do iptables -I
BareMetalInstanceServices -d 169.254.169.254/32 -p tcp -m tcp --dport $i -
m
comment --comment "Rover service access port" -j ACCEPT;done }
```

See [Service Ports](#) for a list of available ports.

Unsupported CLI Commands

The following CLI commands are currently not supported. Workarounds are provided where available.

- **Object Storage CLIs:** `oci os list`

You can only use the `oci os list` command when you include the `--fields` option. For example:

```
# oci os object list --bucket-name generic-image --fields
name,size,timeCreated,md5,etag
{
  "data": [
    {
      "archival-state": null,
      "etag": "b2c123ff0f1231c4c7f41ff92294e4a0-32",
      "md5": "ssYx/w8SUcTH9B/5IpTkoA==-32",
      "name": "exported-image",
      "size": 2132357120,
      "storage-tier": null,
      "time-created": "2022-03-01T19:50:03.076000+00:00",
      "time-modified": null
    },
    {
      "archival-state": null,
      "etag": "fe5e3c12e12e31de65b86722a6fe29e7-32",
```

```

      "md5": "/148A01eMd5luGcipv4p5w==32",
      "name": "imported-
image-20210830-1542_ocidl.image.oc1.iad..uniqueID.oci",
      "size": 2132224000,
      "storage-tier": null,
      "time-created": "2022-03-01T19:50:59.968000+00:00",
      "time-modified": null
    }
  ],
  "prefixes": []
}

```

- **Compute CLIs:** `oci compute instance list-vnics`

The `oci compute instance list-vnics` command lists the VNICs that are attached to the specified instance and is often used to get the public IP for a compute node. This CLI is not currently supported in Roving Edge Infrastructure. You can get VNIC information, including IP address associated with a VNIC attached to a compute node, using any of the following methods:

- **Device Console:** Go to the following location:

Compute > Instances > Instance Details > Attached VNICs

The IP addresses for the VNICs are listed in the dialog box that appears.

- **CLI:** `oci compute instance list-vnics`

First, run the following command to list all the VNIC's attachments:

```
oci compute vnic-attachment list --instance-id <> --all
```

Next, run the following command for the specific VNIC for which you want to get details:

```
oci network vnic get --vnic-id <>
```

The following example shows these two commands run together with their respective returns:

```

# oci compute vnic-attachment list --instance-id
ocidl.instance.orei.orei-1..uniqueID --all
{
  "data": [
    {
      "availability-domain": "orei-1-ad-1",
      "compartment-id": "ocidl.tenancy.orei..uniqueID",
      "display-name": null,
      "id": "ocidl.vnicattachment.orei.orei-1..uniqueID",
      "instance-id": "ocidl.instance.orei.orei-1..uniqueID",
      "lifecycle-state": "ATTACHED",
      "nic-index": 0,
      "subnet-id": "ocidl.subnet.orei.orei-1..uniqueID",
      "time-created": "2022-03-01T21:07:00.937000+00:00",
      "vlan-id": null,
      "vlan-tag": 1,
      "vnic-id": "ocidl.vnic.orei.orei-1..uniqueID"
    }
  ]
}

# oci network vnic get --vnic-id ocidl.vnic.orei.orei-1..uniqueID
{
  "data": {
    "availability-domain": "orei-1-ad-1",
    "compartment-id": "ocidl.tenancy.orei..uniqueID",
    "defined-tags": {},
    "display-name": "test-instance",

```

```

    "freeform-tags": {},
    "hostname-label": "test-instance",
    "id": "ocidl.vnic.orei.orei-1..uniqueID",
    "is-primary": true,
    "lifecycle-state": "AVAILABLE",
    "mac-address": "02:00:17:00:04:00",
    "nsg-ids": [],
    "private-ip": "10.0.0.2",
    "public-ip": "10.145.142.128",
    "skip-source-dest-check": false,
    "subnet-id": "ocidl.subnet.orei.orei-1..",
    "time-created": "2022-03-01T21:07:00.155000+00:00",
    "vlan-id": null
  },
  "etag": "2c082d1c"
}

```

If only one VNIC is attached, you can combine these CLI commands with other Linux tools to limit the output to just the public IP address using the following command:

```

oci compute vnic-attachment list --instance-id <> --all|grep -m 1 vnic-
id|awk -F'"' '{print $4}'|xargs -I{} oci network vnic get --vnic-id {}|
grep public-ip|awk -F'"' '{print $4}'

```

For example:

```

# oci compute vnic-attachment list --instance-id
ocidl.instance.orei.orei-1..uniqueID --all|grep -m 1 vnic-id|awk -F'"'
'{print $4}'|xargs -I{} oci network vnic get --vnic-id {}|grep public-
ip|awk -F'"' '{print $4}'
10.145.142.128

```

Instances for Roving Edge Infrastructure Devices

Describes how to perform compute instance management tasks, including creating, updating, and deleting instances, on your Roving Edge Infrastructure devices.

You can perform the following compute instance tasks:

- [Creating an instance](#)
- [Listing the instances](#)
- [Getting an instance's details](#)
- [Renaming an instance](#)
- [Terminating an instance](#)
- [Powering an instance on and off](#)
- [Getting a Window instance's credentials](#)
- [Using the instance console connection feature](#)

Note:

Roving Edge Infrastructure instances do not support OCI Utilities that the Oracle Linux platform images include. See [Accessing Roving Edge Infrastructure](#) for more information.

See [Working with Instances](#) in the Oracle Cloud Infrastructure documentation for more information on this feature.

Creating an Instance

Describes how to create a compute instance on your Roving Edge Infrastructure device.

You must have at least one VCN and one subnet created before creating an instance. Otherwise, an error message appears when you submit your instance for creation.

If you require more disk space on your VM, you can create and attach a block volume. See the following topics for more information:

- [Creating a Block Volume](#)
- [Attaching a Block Volume](#)

Using the Device Console

1. Open the navigation menu and select **Compute > Instances**. The **Instances** page appears. All instances are listed in tabular form.
2. Click **Create Instance**. The **Create Compute Instance** dialog box appears.
3. Complete the following:
 - **Name**: Enter a name for the instance.
 - **Image or operating system**: Click **Change Image**. The **Browse All Images** dialog box appears. Select one of the following image options:
 - **Platform Images** tab: Check the pre-built image you want for the instance from the list and click **Select Image**.
 - **Custom Images** tab: Click **Select Image**. The image you selected is displayed in the **Image or operating system** box.
 - **Shape**: Click **Change Shape**. The **Browse All Shapes** dialog box appears. Select a **Standard** or **Specialty** shape type, then select one of the corresponding shapes that appear. Click **Select Shape**. The shape you selected is displayed in the **Shape** box.
 - **Select a virtual cloud network**: Select a virtual cloud network from the list.
 - **Select a subnet**: Select a subnet associated with the virtual cloud network from the list.
 - **IP address**: Select an IP address option:
 - **Assign a public IP address** (if selected, an IP address from the external CIDR is used)
 - **Do not assign a public IP address**
 - **Specify a custom boot volume size**: Check if you do not want to use the default boot volume size. Enter the size in the **Boot volume size** box.
 - **SSH key**: Select an SSH key option:
 - **Choose SSH key file**: Click **browse to a location** and navigate to your SSH key file where you can select it for upload. You can also drag the file into the **SSH keys** box.
 - **Paste SSH keys**: Copy and paste the SSH key directly into the **SSH keys** box.
4. Click **Create**. Upon creation of the instance, the new instance's **Details** page opens automatically.
5. Review the contents of the instance's **Details** page. It contains information such as its current state (indicated by the image in the upper left corner), IP addresses used, the image used, shape settings. You can view the boot volume, and attached VNICs by clicking their respective links in the lower left corner. Creation of the instance can take several minutes. During this time, the state is **Provisioning**. When the creation is complete, the state changes to **Running**. This state indicates that the instance is now launched.

Note:

If the original image had the user keys on it, the new keys might not be added to the resulting instance, depending on the image specifics.

Note:

Your instance capacity is limited by the available cores and available memory. If you see "out of capacity" messages on instance creation, terminate some of the existing instances that are not used and try again. Stopped instances count toward the resources used. Terminate the instance to free up the resources.

Using the CLI

Use the `oci compute instance launch` command and required parameters to create a compute instance on your Roving Edge Infrastructure devices:

```
oci compute instance launch --compartment-id compartment_ocid --availability-domain orei-1-ad-1 --shape shape [OPTIONS]
```

Refer to your Roving Edge Infrastructure device's CLI help for a list of parameters available for this command. See [Accessing Command Line Interface Help](#) on page 53.

To determine your Roving Edge Infrastructure device compartment OCID, see [Compartments](#).

For set up information regarding CLIs on your Roving Edge Infrastructure device, see [Using the Command Line Interface](#).

Using the API

Run the `LaunchInstance` operation to create a compute instance on your Roving Edge Infrastructure devices.

Listing Instances for a Roving Edge Infrastructure Device

Describes how to list the compute instances on your Roving Edge Infrastructure device.

Using the Device Console

1. Open the navigation menu and select **Compute > Instances**. The **Instances** page appears. All instances are listed in tabular form.
2. Select a **State** from the list to limit the instances displayed to that state.

Using the CLI

Use the `oci compute instance list` command and required parameters to list the compute instances on your Roving Edge Infrastructure devices:

```
oci compute instance list --compartment-id compartment_ocid [OPTIONS]
```

To determine your Roving Edge Infrastructure device compartment OCID, see [Compartments](#).

Refer to your Roving Edge Infrastructure device's CLI help for a list of parameters available for this command. See [Accessing Command Line Interface Help](#) on page 53.

For set up information regarding CLIs on your Roving Edge Infrastructure device, see [Using the Command Line Interface](#).

Using the API

Run the `ListInstances` operation to display a list of instances.

Getting an Instance's Details

Describes how to get the details of a compute instance on your Roving Edge Infrastructure devices.

Using the Device Console

1. Open the navigation menu and select **Compute > Instances**. The **Instances** page appears. All instances are listed in tabular form.
2. Select a **State** from the list to limit the instances displayed to that state.
3. Click the instance whose details you want to get. The instance's **Details** page appears.

The **Details** page contains a variety of information regarding the instance, including the shape used, the attached primary VNIC, and the launch options. You can also access additional information from the resource pages accessible under **Resources**.

Using the CLI

Use the `oci compute instance get` command and required parameters to get the details of a compute instance on your Roving Edge Infrastructure devices:

```
oci compute instance get --instance-id instance_ocid [OPTIONS]
```

Refer to your Roving Edge Infrastructure device's CLI help for a list of parameters available for this command. See [Accessing Command Line Interface Help](#) on page 53.

For set up information regarding CLIs on your Roving Edge Infrastructure device, see [Using the Command Line Interface](#).

Using the API

Run the `GetInstance` operation to get the details of a compute instance on your Roving Edge Infrastructure devices.

Renaming an Instance for a Roving Edge Infrastructure Device

Describes how to rename a compute instance on your Roving Edge Infrastructure device.

Using the Device Console

1. Open the navigation menu and select **Compute > Instances**. The **Instances** page appears. All instances are listed in tabular form.
2. Select a **State** from the list to limit the instances displayed to that state.
3. Click the instance that you want to rename. The instance's **Details** page appears.
4. Click **More Actions** and select **Edit Name**. The **Edit Name** dialog box appears.
5. Rename the instance.
6. Click **Save Changes**.

Using the CLI

Use the `oci compute instance update` command and required parameters to rename a compute instance on your Roving Edge Infrastructure devices:

```
oci compute instance update --instance-id instance_ocid [OPTIONS]
```

Refer to your Roving Edge Infrastructure device's CLI help for a list of parameters available for this command. See [Accessing Command Line Interface Help](#) on page 53.

For set up information regarding CLIs on your Roving Edge Infrastructure device, see [Using the Command Line Interface](#).

Using the API

Run the `UpdateInstance` operation to rename a compute instance on your Roving Edge Infrastructure devices.

Terminating an Instance for a Roving Edge Infrastructure Device

Describes how to terminate a compute instance on your Roving Edge Infrastructure device.

Using the Device Console

1. Open the navigation menu and select **Compute > Instances**. The **Instances** page appears. All instances are listed in tabular form.
2. Select a **State** from the list to limit the instances displayed to that state.
3. Click the instance that you want to terminate. The instance's **Details** page appears.
4. Click **More Actions** and select **Terminate**.
5. Confirm the termination when prompted.

Using the CLI

Use the `instance terminate` command and required parameters to terminate a compute instance on your Roving Edge Infrastructure devices:

```
oci compute instance terminate --instance-id instance_ocid [OPTIONS]
```

Refer to your Roving Edge Infrastructure device's CLI help for a list of parameters available for this command. See [Accessing Command Line Interface Help](#) on page 53.

For set up information regarding CLIs on your Roving Edge Infrastructure device, see [Using the Command Line Interface](#).

Using the API

Run the `TerminateInstance` operation to terminate a compute instance on your Roving Edge Infrastructure devices.

Powering an Instance On and Off for a Roving Edge Infrastructure Device

Describes how to power a compute instance on or off on your Roving Edge Infrastructure devices.

Note:

The Device Console does not accurately reflect the instance's lifecycle state. It displays the instance state as **Running** when actually in a **Started** state. Use the CLI method to accurately determine the instance lifecycle state when powering on and off.

See [Stopping and Starting an Instance](#) in the Oracle Cloud Infrastructure documentation for more information on this feature.

Using the Device Console

1. Open the navigation menu and select **Compute > Instances**. The **Instances** page appears. All instances are listed in tabular form.
2. Select a **State** from the list to limit the instances displayed to that state.
3. Click the instance that you want to power on or off. The instance's **Details** page appears.
4. Click one of the following actions:
 - **Start**: Restarts a stopped instance.
 - **Stop**: Gracefully shuts down the instance by sending a shutdown command to the operating system.

Note:

If the applications that run on the instance take a long time to shut down, they could be improperly stopped, resulting in data corruption. To avoid this occurrence, shut down the instance using the commands available in the OS before you stop the instance using the Device Console.

- **Reboot**: Gracefully reboots the instance by sending a shutdown command to the operating system, and then powers the instance back on.

Using the CLI

Use the `oci compute instance action` command and required parameters to power on or off a compute instance on your Roving Edge Infrastructure devices:

```
oci compute instance action --instance-id instance_ocid --action action [OPTIONS]
```

Refer to your Roving Edge Infrastructure device's CLI help for a list of parameters available for this command. See [Accessing Command Line Interface Help](#) on page 53.

For set up information regarding CLIs on your Roving Edge Infrastructure device, see [Using the Command Line Interface](#).

Using the API

Run the `InstanceAction` method to power on or off a compute instance on your Roving Edge Infrastructure devices.

Getting a Windows Instance's Credentials for a Roving Edge Infrastructure Device

Describes how to get Windows instance credentials on your Roving Edge Infrastructure device.

See [Connecting to Your Windows Instance](#) in the Oracle Cloud Infrastructure documentation for more information on this feature.

Use the `oci compute instance get-windows-initial-creds` command and required parameters to get Windows instance credentials on your Roving Edge Infrastructure devices:

```
oci compute instance get-windows-initial-creds --instance-id instance_ocid
[OPTIONS]
```

Refer to your Roving Edge Infrastructure device's CLI help for a list of parameters available for this command. See [Accessing Command Line Interface Help](#) on page 53.

For set up information regarding CLIs on your Roving Edge Infrastructure device, see [Using the Command Line Interface](#).

Instance Work Requests

Learn about instance work requests, which is an activity log that tracks each step in an asynchronous operation. Use work requests to monitor the progress of long-running operations.

You can perform the following instance work request tasks:

- [Listing an instance's work requests](#)
- [Getting an instance's work request details](#)
- [Listing an instance's work request log entries](#)
- [Listing an instance's work request errors](#)

Listing an Instance's Work Requests for Roving Edge Infrastructure

View a list of an instance's work requests for Roving Edge Infrastructure.

A work request is an activity log that tracks each step in an asynchronous operation. Use work requests to monitor the progress of long-running operations.

Using the Device Console

1. Open the navigation menu and select **Compute > Instances**. The **Instances** page appears. All instances are listed in tabular form.
2. (optional) Select a **State** from the list to limit the instances displayed to that state.
3. Click the instance whose work request details you want to get. The **Details** page for that instance appears.
4. Click **Work Requests** under **Resources**.

The **Work Requests** page appears. All the work requests are listed in tabular form.

Using the CLI

Use the `oci work-requests work-request list` command and required parameters to view a list of an instance's work requests for a Roving Edge Infrastructure device:

```
oci work-requests work-request list --compartment-id compartment_ocid --
resource-id instance_ocid [OPTIONS]
```

For a complete list of flags and variable options for CLI commands, see the [Command Line Reference](#).

Using the API

Run the [ListWorkRequests](#) operation to view a list of an instance's work requests for a Roving Edge Infrastructure device.

Getting an Instance Work Request's Details for Roving Edge Infrastructure

View the details and access additional information regarding an instance's work request for a Roving Edge Infrastructure device.

A work request is an activity log that tracks each step in an asynchronous operation. Use work requests to monitor the progress of long-running operations.

Using the Device Console

1. Open the navigation menu and select **Compute > Instances**. The **Instances** page appears. All instances are listed in tabular form.
2. (optional) Select a **State** from the list to limit the instances displayed to that state.
3. Click the instance whose work request details you want to get. The **Details** page for that instance appears.
4. Click **Work Requests** under **Resources**. The **Work Requests** page appears. All the work requests are listed in tabular form.
5. Click the work request whose details you want to get. The **Details** page for that work request appears. The **Details** page contains information on the work request, including the time the job was accepted, started, and completed.
6. Click any of the following commands under **Resources** to view additional information on the work request:
 - **Log Messages**: Displays general entries in the log and their timestamps.
 - **Error Messages**: Displays error entries in the log and their timestamps.
 - **Associated Resources**: Displays a link to the associated compute instance.

When the **Details** page indicates the work request has succeeded and displays a **Finished** time, the work request is complete.

Using the CLI

Use the `oci work-requests work-request get` command and required parameters to view the details and access additional information regarding an instance's work request for a Roving Edge Infrastructure device:

```
oci work-requests work-request get --work-request-id work_request_ocid  
[OPTIONS]
```

For a complete list of flags and variable options for CLI commands, see the [Command Line Reference](#).

Using the API

Run the [GetWorkRequest](#) operation to view the details and access additional information regarding an instance's work request for a Roving Edge Infrastructure device.

Listing an Instance's Work Request Log Entries for Roving Edge Infrastructure

View a list of log entries for an instance's work request for a Roving Edge Infrastructure device.

A work request is an activity log that tracks each step in an asynchronous operation. Use work requests to monitor the progress of long-running operations.

Using the Device Console

1. Open the navigation menu and select **Compute > Instances**. The **Instances** page appears. All instances are listed in tabular form.
2. (optional) Select a **State** from the list to limit the instances displayed to that state.
3. Click the instance whose work request details you want to get. The **Details** page for that instance appears.
4. Click **Work Requests** under **Resources**. The **Work Requests** page appears. All the work requests are listed in tabular form.

5. Click the work request whose details you want to get. The **Details** page for that work request appears. The **Details** page contains information on the work request, including the time the job was accepted, started, and completed.
6. Click **Log Messages** under **Resources**. The **Log Message** page appears.

The **Log Messages** page displays general entries in the log and their timestamps.

Using the CLI

Use the `oci work-requests work-request-log-entry list` command and required parameters to view a list of log entries for an instance's work request for a Roving Edge Infrastructure device:

```
oci work-requests work-request-log-entry list --work-request-
id work_request_ocid [OPTIONS]
```

For a complete list of flags and variable options for CLI commands, see the [Command Line Reference](#).

Using the API

Run the `ListWorkRequestLogs` operation to view a list of log entries for an instance's work request for a Roving Edge Infrastructure device.

Listing an Instance's Work Request Errors for Roving Edge Infrastructure

View a list of errors for an instance's work request for a Roving Edge Infrastructure device.

A work request is an activity log that tracks each step in an asynchronous operation. Use work requests to monitor the progress of long-running operations.

Using the Device Console

1. Open the navigation menu and select **Compute > Instances**. The **Instances** page appears. All instances are listed in tabular form.
2. (optional) Select a **State** from the list to limit the instances displayed to that state.
3. Click the instance whose work request details you want to get. The **Details** page for that instance appears.
4. Click **Work Requests** under **Resources**. The **Work Requests** page appears. All the work requests are listed in tabular form.
5. Click the work request whose details you want to get. The **Details** page for that work request appears. The **Details** page contains information on the work request, including the time the job was accepted, started, and completed.
6. Click **Error Messages** under **Resources**. The **Error Messages** page appears.

The **Error Messages** page displays error entries in the log and their timestamps.

Using the CLI

Use the `oci work-requests work-request-error list` command and required parameters to view a list of errors for an instance's work request for a Roving Edge Infrastructure device:

```
oci work-requests work-request-error list --work-request-
id work_request_ocid [OPTIONS]
```

For a complete list of flags and variable options for CLI commands, see the [Command Line Reference](#).

Using the API

Run the `ListWorkRequestErrors` operation to view a list of errors for an instance's work request for a Roving Edge Infrastructure device.

Instance Console Connection

Describes how to create and manage instance console connections on a Roving Edge Infrastructure device.

Use the instance console connection feature to add support for console access to compute instances. This access lets you troubleshoot malfunctioning instances remotely via the following types of SSH-tunneled connections:

- Serial

- Virtual Network Computing (VNC)

You can have only one active console connection. If you want to create and use a different console connection than the one that is currently active (as indicated by it being listed as in an **Active** state), you must delete the currently-active console connection first, then create a new console connection. Any deleted console connection is listed as being in a **Deleted** state for a limited period of time, before it is removed permanently. You cannot revert a deleted console connection back to being active.

You can perform the following instance console connection tasks:

- [Creating an Instance Console Connection](#)
- [Listing the Instance Console Connections](#)
- [Getting an Instance Console Connection's Details](#)
- [Editing an Instance Console Connection](#)
- [Deleting an Instance Console Connection](#)
- [Connecting to the Console of an Instance](#)

Unsupported CLI Commands and Parameters

The Roving Edge Infrastructure instance console connection feature does not support all the CLI commands and parameters that are supported by the Oracle Cloud Infrastructure Cloud-based version of this feature:

- Plink command (`oci compute instance-console-connection get-plink-connection-string`)
- Defined tags parameter for all commands (`--defined-tags`)

Exiting the Instance Console Connection

To exit the Serial Console connection:

When using SSH, the `~` character at the beginning of a new line is used as an escape character.

- To exit the Serial Console, enter:

```
~.
```

- To suspend the SSH session, enter:

```
~^z
```

The `^` character represents the **CTRL** key

- To see all the SSH escape commands, enter:

```
~?
```

To exit the VNC console connection:

1. Close the VNC client.
2. Open the Terminal or PowerShell window and enter `CTRL C`

When you are finished using the console connection, delete the connection for the instance.

Creating an Instance Console Connection

Describes how to create an instance console connection for a Roving Edge Infrastructure device.

When you have created the console connection, connect it to an instance. See [Connecting to the Console of an Instance](#).

Using the Device Console

1. Open the navigation menu and select **Compute > Instances**. The **Instances** page appears. All instances are listed in tabular form.
2. (optional) Select a **State** from the list to limit the instances displayed to that state.

3. Click the instance for which you want to create the console connection. The instance's **Details** page appears.
4. Click **Console Connection** under **Resources**. The **Console Connection** page appears. All console connections are listed in tabular form.
5. Click **Create Console Connection**. The **Create Console Connection** dialog box appears.
6. Select one of the following options to generate a public key:
 - **Upload public key file (.pub)**: Drag and drop your `.pub` file or click **Select One** to navigate to where you can upload the `.pub` file.
 - **Paste public key**: Copy the public key from its source and paste it into the box.
7. Click **Create Console Connection**. The **Create Console Connection** dialog box closes and the **Console Connection** page displays an entry for the console connection you created, including the state of its progress. When the state of the console connection is **Active**, it is ready.

Using the CLI

Use the `oci compute instance-console-connection create` command and required parameters to create an instance console connection for a Roving Edge Infrastructure device:

```
oci compute instance-console-connection create --instance-id instance_ocid
--ssh-public-key-file ssh_public_key_file [OPTIONS]
```

Refer to your Roving Edge Infrastructure device's CLI help for a list of parameters available for this command. See [Accessing Command Line Interface Help](#) on page 53.

For set up information regarding CLIs on your Roving Edge Infrastructure device, see [Using the Command Line Interface](#).

Using the API

Run the `CreateInstanceConsoleConnection` operation to create an instance console connection for a Roving Edge Infrastructure device.

Listing the Instance Console Connections

Describes how to list the instance console connections for a Roving Edge Infrastructure device.

Using the Device Console

1. Open the navigation menu and select **Compute > Instances**. The **Instances** page appears. All instances are listed in tabular form.
2. (optional) Select a **State** from the list to limit the instances displayed to that state.
3. Click the instance for which you want to list the console connections. The instance's **Details** page appears.
4. Click **Console Connection** under **Resources**. The **Console Connection** page appears.

All console connections are listed in tabular form.

Using the CLI

Use the `oci compute instance-console-connection list` command and required parameters to list the instance console connections for a Roving Edge Infrastructure device:

```
oci compute instance-console-connection list --compartment-
id compartment_ocid [OPTIONS]
```

Refer to your Roving Edge Infrastructure device's CLI help for a list of parameters available for this command. See [Accessing Command Line Interface Help](#) on page 53.

To determine your Roving Edge Infrastructure device compartment OCID, see [Compartments](#).

For set up information regarding CLIs on your Roving Edge Infrastructure device, see [Using the Command Line Interface](#).

Using the API

Run the [ListInstanceConsoleConnections](#) operation to list the instance console connections for a Roving Edge Infrastructure device.

Getting an Instance Console Connection's Details

Describes how to get an instance console connection's details for a Roving Edge Infrastructure device.

See [Connecting to the Console of an Instance](#) for details on how to connect to the console of an instance.

Using the Device Console

1. Open the navigation menu and select **Compute > Instances**. The **Instances** page appears. All instances are listed in tabular form.
2. (optional) Select a **State** from the list to limit the instances displayed to that state.
3. Click the instance containing the console connection whose details you want to get. The instance's **Details** page appears.
4. Click **Console Connection** under **Resources**. The **Console Connection** page appears.

The **Console Connection** page displays all console connections in tabular form. The **State** column displays the state of the instance console connection for each connection entry and the **Public Key for Fingerprint** column displays the finger for each connection entry.

Using the CLI

Use the [oci compute instance-console-connection get](#) command and required parameters to get an instance console connection's details for a Roving Edge Infrastructure device:

```
oci compute instance-console-connection get --instance-console-connection-id instance_console_connection_ocid [OPTIONS]
```

Refer to your Roving Edge Infrastructure device's CLI help for a list of parameters available for this command. See [Accessing Command Line Interface Help](#) on page 53.

For set up information regarding CLIs on your Roving Edge Infrastructure device, see [Using the Command Line Interface](#).

Using the API

Run the [GetInstanceConsoleConnection](#) operation to get an instance console connection's details for a Roving Edge Infrastructure device.

Editing an Instance Console Connection

Describes how to edit an instance console connection for a Roving Edge Infrastructure device.

Using the Device Console

This task can't be performed using the Device Console.

Using the CLI

Use the [oci compute instance-console-connection update](#) command and required parameters to edit an instance console connection for a Roving Edge Infrastructure device:

```
oci compute instance-console-connection update --instance-console-connection-id instance_console_connection_ocid [OPTIONS]
```

Refer to your Roving Edge Infrastructure device's CLI help for a list of parameters available for this command. See [Accessing Command Line Interface Help](#) on page 53.

For set up information regarding CLIs on your Roving Edge Infrastructure device, see [Using the Command Line Interface](#).

Using the API

Run the [UpdateInstanceConsoleConnection](#) operation to edit an instance console connection for a Roving Edge Infrastructure device.

Deleting an Instance Console Connection

Describes how to delete an instance console connection from a Roving Edge Infrastructure device.

Using the Device Console

1. Open the navigation menu and select **Compute > Instances**. The **Instances** page appears. All instances are listed in tabular form.
2. (optional) Select a **State** from the list to limit the instances displayed to that state.
3. Click the instance containing the console connection you want to delete. The instance's **Details** page appears.
4. Click **Console Connection** under **Resources**. The **Console Connection** page appears.
5. Click the Actions menu (⋮) to the right of the console connection entry you want to delete, then click **Delete Console Connection**. The **Delete Console Connection** dialog box appears.
6. Confirm the deletion.

The **Console Connection** page reappears with the connection you deleted listed as **Deleted**.

Using the CLI

Use the [oci compute instance-console-connection delete](#) command and required parameters to delete an instance console connection from a Roving Edge Infrastructure device:

```
oci compute instance-console-connection delete --instance-console-connection-id instance_console_connection_ocid [OPTIONS]
```

Refer to your Roving Edge Infrastructure device's CLI help for a list of parameters available for this command. See [Accessing Command Line Interface Help](#) on page 53.

For set up information regarding CLIs on your Roving Edge Infrastructure device, see [Using the Command Line Interface](#).

Using the API

Run the [DeleteInstanceConsoleConnection](#) operation to delete an instance console connection from a Roving Edge Infrastructure device.

Connecting to the Console of an Instance

Describes how to connect to the serial or VNC console of an instance for a Roving Edge Infrastructure device using the console connection you create.

Using the Device Console

1. Open the navigation menu and select **Compute > Instances**. The **Instances** page appears. All instances are listed in tabular form.
2. (optional) Select a **State** from the list to limit the instances displayed to that state.
3. Click the instance for which you want to create the console connection. The instance's **Details** page appears.
4. Click **Console Connection** under **Resources**. The **Console Connection** page appears. All console connections are listed in tabular form.
5. Click the Actions menu (⋮) to the right of the console connection entry you want to connect to an instance and select one of the following options:
 - **Copy Serial Console Connection for Linux/Mac**
 - **Copy Serial Console Connection for Windows**
 - **Copy VNC Connection for Linux/Mac**
 - **Copy VNC Connection for Windows**

The connection information you select is copied to your clipboard. The connection string resembles the following:

```
ssh -o ProxyCommand='ssh -W %h:%p -p 19022
  ocid1.instanceconsoleconnection.orei.orei-1..exampleuniqueID@x.x.x.x
  ocid1.instance.orei.orei-1..exampleuniqueID
```

where @x.x.x.x is the Roving Edge Infrastructure device's IP/resolvable domain name. Use this for troubleshooting.

If you have not setup your local SSH config to provide the required private key, modify the string to provide the key:

```
ssh -i ./ssh-key-name.key -o ProxyCommand='ssh -i ./ssh-key-name.key -W
  %h:%p -p 19022
  ocid1.instanceconsoleconnection.orei.orei-1..exampleuniqueID@x.x.x.x
  ocid1.instance.orei.orei-1..exampleuniqueID
```

On newer versions of the SSH Client on Macintosh computers, you may have to explicitly enable RSA SSH keys. In ~/.ssh/config add:

```
Host *
  HostkeyAlgorithms +ssh-rsa
  PubkeyAcceptedAlgorithms +ssh-rsa
```

6. Open a command prompt window and paste the clipboard contents into it. Press **Enter**. When you first connect to the Serial Console, you are prompted to validate the fingerprint of the server host key. The fingerprint of the server host key is the SHA256 hash of the server host's public SSH key. The server SSH handshake response is signed with the associated private key. Validating the server host key's fingerprint protects against potential attacks.

If the pasting and entering of the clipboard contents is successful, the following banner appears in the command prompt window.

```
=====
IMPORTANT: Use a console connection to troubleshoot a malfunctioning
  instance. For normal operations,
you should connect to the instance using a Secure Shell (SSH) or Remote
  Desktop connection.
For steps, see https://docs.cloud.oracle.com/iaas/Content/Compute/Tasks/
accessinginstance.htm

For more information about troubleshooting your instance using a console
  connection, see the documentation:
https://docs.cloud.oracle.com/en-us/iaas/Content/Compute/References/
serialconsole.htm#four
=====
```

Configuring Multiple VNICs for Roving Edge Infrastructure Devices

Describes how to configure your instance to use multiple VNICs on a Roving Edge Infrastructure device.

When you create multiple virtual network interface cards (VNICs) on your instance using Oracle Cloud Infrastructure, you can use the script `secondary_vnic_all_configure.sh` to configure them. The script also configures jumbo maximum transfer unit (MTU) on secondary VNICs.

You can use this same script when creating multiple VNICs for an instance created on a Roving Edge Infrastructure device. Download this script to your instance before disconnecting your device from the network. Run this script each time you reboot the instance by adding the script to a service file. Then enable the service to run on boot.

If your instance is configured with multiple VNICs, Oracle recommends that you configure `default.rp_filter` to either 0 (no reverse path filtering) or 2 (loose mode of reverse path filtering) in their instance so that any of the public IP's assigned to the VNICs can access the instance.

Updating a Roving Edge Infrastructure Device VM when the IP Pool Range Changes

Describes how to update your VM's public IP when you change your instance's public IP address pool range without having to recreate the instances.

You can change your VM's public IP range without having to recreate your VMs. Updating your VMs when the IP address pool changes requires you to perform the following tasks:

- Configuring the attached VNIC for no public IP. You can do this through the Device Console.
 - Use the Serial Console to specify the updated pool range of public IP addresses available for use.
 - Use the Device Console to reconfigure the attached VNIC back to using an ephemeral or reserved public IP.
1. Open the navigation menu and select **Compute > Instances**. The **Instances** page appears. All instances are listed in tabular form.
 2. Select a **State** from the list to limit the instances displayed to that state.
 3. Click the instance whose public IP address you want to change. The instance's **Details** page appears.
 4. Click **Attached VNICs** under **Resources**. The **Attached VNICs** page appears.
 5. Click the attached VNIC whose IP address you want to update. The attached VNIC's **Details** page appears.
 6. Click **IP Addresses** under **Resources**. The IP Addresses page appears. The IP addresses are displayed in tabular form.
 7. Click the Actions menu (⋮) next to the IP address you need to make private and click **Edit**. The **Edit Private IP Address** dialog box appears.
 8. Select **No public IP** and click **Update**.
 9. Open the Roving Edge Infrastructure device's Serial Console. See [Operating the Serial Console](#) on page 37.
 10. Select **Configure Networking**. The **Network Configuration** menu appears.
 11. Select **Display Public IP Pool Status**. The Serial Console displays the public IP address pool ranges. Press **ENTER** to exit.
 12. Select **Set IP Pool Range for Compute Instances**. Enter a list of IP address ranges separated by **ENTER**. Use the following format: `x.x.x.x-y.y.y.y` to specify the beginning and end of the range. If the range is a single address, just enter that address by itself. Press **ENTER** to exit.
 13. Reopen the **Edit Private IP Address** dialog box and select the **Ephemeral public IP** or **Reserved public IP** option.
 14. (optional) Enter the name of the ephemeral or reserved public IP address in the associated **Name** box.

Custom Images

Describes how to managing custom image tasks associated with launching instances on your Roving Edge Infrastructure devices.

Note:

- The maximum size of an object you can use with Roving Edge Infrastructure devices is 10 TiB. Any custom images greater than 10 TiB in size are not provisioned onto your Roving Edge Infrastructure device nor included in a data synchronization.
- You cannot create custom images or export them using a Roving Edge Infrastructure device.

You can perform the following custom image management tasks:

- [Importing a Custom Image](#)
- [Listing Images](#)

- [Getting an Image's Details](#)
- [Editing an Image](#)
- [Removing an Image](#)
- [Creating a Custom Image from an Instance](#)
- [Exporting a Custom Image to Object Storage](#)
- [Adding an Image Shape Compatibility Entry](#)
- [Listing Image Shape Compatibility Entries](#)
- [Getting an Image Shape Compatibility Entry's Details](#)
- [Removing an Image Shape Compatibility Entry](#)

Note:

See [Managing Custom Images](#) in the Oracle Cloud Infrastructure documentation for more information on this feature.

Importing a Custom Image from a Bucket into a Roving Edge Infrastructure Device

Describes how to import a custom image from an object storage bucket for use in launching an instance on your Roving Edge Infrastructure device.

Roving Edge Infrastructure supports importing QCOW2 and OCI type images.

Using the Device Console

1. Open the navigation menu and select **Compute > Images**. The **Custom Images** page appears. All custom images are listed in tabular form.
2. Click **Import Image**. The **Import Image** dialog box appears.
3. Enter a **Name** for the image.
4. Select the **Operating System**:
 - For Linux images, select **Linux**.
 - For Windows images, select **Windows**. Select the **Operating System Version**, and then certify that the selected operating system complies with Microsoft licensing agreements.
5. Click the **Import from an Object Storage bucket** option.
6. Select the **Bucket** that contains the image.
7. Select the image file from the **Object Name** list.
8. Select the **Image Type** option:
 - **QCOW2**
 - **OCI**
9. Click **Import Image**.

After you click **Import Image**, you'll see the imported image in the **Custom Images** list for the compartment, with a state of **Importing**. To track the progress of the operation, you can monitor the associated work request.

When the import completes successfully, the state changes to **Available**. If the state does not change, or no entry appears in the **Custom Images** list, the import failed. If the import failed, ensure you have read access to the Object Storage object, and that the object contains a supported image.

Using the CLI

Use the `oci compute image import from-object` command and required parameters to import a custom image for use in launching an instance on your Roving Edge Infrastructure devices:

```
oci compute image import from-object --compartment-id compartment_ocid --
bucket-name bucket_name --name name [OPTIONS]
```

To determine your Roving Edge Infrastructure device compartment OCID, see [Compartments](#).

Refer to your Roving Edge Infrastructure device's CLI help for a list of parameters available for this command. See [Accessing Command Line Interface Help](#) on page 53.

For set up information regarding CLIs on your Roving Edge Infrastructure device, see [Using the Command Line Interface](#).

Using the API

Run the [CreateImage](#) operation and specify [ImageSourceDetails](#) in the request body to import an image from object storage.

Importing a Custom Image from a URL for a Roving Edge Infrastructure Device

Describes how to import a custom image from an object storage URL for use in launching an instance on your Roving Edge Infrastructure device.

Roving Edge Infrastructure supports importing QCOW2 type images. Roving Edge Infrastructure also supports importing some OCI type images, but in some instances importing an OCI type image fails.

Roving Edge Infrastructure supports importing an image from a Roving Edge Infrastructure source URL and OCI Pre-authenticated request (PAR) URL only. See [Using Pre-Authenticated Requests](#) in the Oracle Cloud Infrastructure documentation for more information on this feature.

Using the Device Console

1. Open the navigation menu and select **Compute > Images**. The **Custom Images** page appears. All custom images are listed in tabular form.
2. Click **Import Image**. The **Import Image** dialog box appears.
3. Enter a **Name** for the image.
4. Select the **Operating System**:
 - For Linux images, select **Linux**.
 - For Windows images, select **Windows**. Select the **Operating System Version**, and then certify that the selected operating system complies with Microsoft licensing agreements.
5. Click the **Import from an Object Storage URL** option.
6. Enter the URL to the image in the **Object Storage URL** box.
7. Select the **Image Type** option:
 - **QCOW2**
 - **OCI**
8. Click **Import Image**.

After you click **Import Image**, you'll see the imported image in the **Custom Images** list for the compartment, with a state of **Importing**. To track the progress of the operation, you can monitor the associated work request.

When the import completes successfully, the state changes to **Available**. If the state does not change, or no entry appears in the **Custom Images** list, the import failed. If the import failed, ensure you have read access to the Object Storage object, and that the object contains a supported image.

Using the CLI

Use the `oci compute image import from-object-uri` command and required parameters to import a custom image from a URI for use in launching an instance on your Roving Edge Infrastructure devices:

```
oci compute image import from-object-uri --compartment-id compartment_ocid
  --uri uri --name name [OPTIONS]
```

To determine your Roving Edge Infrastructure device compartment OCID, see [Compartments](#).

Refer to your Roving Edge Infrastructure device's CLI help for a list of parameters available for this command. See [Accessing Command Line Interface Help](#) on page 53.

For set up information regarding CLIs on your Roving Edge Infrastructure device, see [Using the Command Line Interface](#).

Using the API

Run the [CreateImage](#) operation and specify [ImageSourceDetails](#) in the request body to import an image from object storage.

Listing Images for a Roving Edge Infrastructure Device

Describes how to list the custom images for use in launching an instance on your Roving Edge Infrastructure device.

Using the Device Console

1. Open the navigation menu and select **Compute > Images**. The **Custom Images** page appears. All custom images are listed in tabular form.
2. Select a **State** from the list to limit the custom images displayed to that state.

Using the CLI

Use the `oci compute image list` command and required parameters to list the custom images for use in launching an instance on your Roving Edge Infrastructure devices:

```
oci compute image list --compartment-id compartment_ocid [OPTIONS]
```

To determine your Roving Edge Infrastructure device compartment OCID, see [Compartments](#).

Refer to your Roving Edge Infrastructure device's CLI help for a list of parameters available for this command. See [Accessing Command Line Interface Help](#) on page 53.

For set up information regarding CLIs on your Roving Edge Infrastructure device, see [Using the Command Line Interface](#).

Using the API

Run the [ListImages](#) operation to list the custom images for use in launching an instance on your Roving Edge Infrastructure devices.

Getting an Image's Details for a Roving Edge Infrastructure Device

Describes how to get the details of a custom image for use in launching an instance on your Roving Edge Infrastructure device.

Using the Device Console

1. Open the navigation menu and select **Compute > Images**. The **Custom Images** page appears. All custom images are listed in tabular form.
2. Select a **State** from the list to limit the images displayed to that state.
3. Click the image whose details you want to get. The image's **Details** page appears.

Using the CLI

Use the `oci compute image get` command and required parameters to get the details of a custom image for use in launching an instance on your Roving Edge Infrastructure devices:

```
oci compute image get --image-id image_ocid [OPTIONS]
```

Refer to your Roving Edge Infrastructure device's CLI help for a list of parameters available for this command. See [Accessing Command Line Interface Help](#) on page 53.

For set up information regarding CLIs on your Roving Edge Infrastructure device, see [Using the Command Line Interface](#).

Using the API

Run the [GetImage](#) operation to get the details of a custom image for use in launching an instance on your Roving Edge Infrastructure devices.

Editing an Image for a Roving Edge Infrastructure Device

Describes how to edit a custom image for use in launching an instance on your Roving Edge Infrastructure device.

Using the Device Console

1. Open the navigation menu and select **Compute > Images**. The **Custom Images** page appears. All custom images are listed in tabular form.
2. Select a **State** from the list to limit the images displayed to that state.
3. Click the image whose details you want to get. The image's **Details** page appears.
4. Click **Edit Details**.
5. Make your edits. See [Importing a Custom Image](#) for descriptions of the settings.
6. Click **Save Changes**.

Note:

After you add shape compatibility to an image, test the image on the shape to ensure that the image actually works on the shape. Some images (especially Windows) might never be cross-compatible with other shapes because of driver or hardware differences.

Using the CLI

Use the `oci compute image update` command and required parameters to edit a custom image for use in launching an instance on your Roving Edge Infrastructure devices:

```
oci compute image update --image-id image_ocid [OPTIONS]
```

Refer to your Roving Edge Infrastructure device's CLI help for a list of parameters available for this command. See [Accessing Command Line Interface Help](#) on page 53.

For set up information regarding CLIs on your Roving Edge Infrastructure device, see [Using the Command Line Interface](#).

Using the API

Run the [UpdateImage](#) operation to edit a custom image for use in launching an instance on your Roving Edge Infrastructure devices.

Removing an Image from a Roving Edge Infrastructure Device

Describes how to remove a custom image for use in launching an instance from your Roving Edge Infrastructure device.

Using the Device Console

1. Open the navigation menu and select **Compute > Images**. The **Custom Images** page appears. All custom images are listed in tabular form.
2. Select a **State** from the list to limit the custom images displayed to that state.
3. Click the custom image whose details you want to get. The custom image's **Details** page appears.
4. Click **Delete**.
5. Confirm the deletion when prompted.

Using the CLI

Use the `oci compute image delete` command and required parameters to remove a custom image for use in launching an instance from your Roving Edge Infrastructure devices:

```
oci compute image delete --image-id image_ocid [OPTIONS]
```

Refer to your Roving Edge Infrastructure device's CLI help for a list of parameters available for this command. See [Accessing Command Line Interface Help](#) on page 53.

For set up information regarding CLIs on your Roving Edge Infrastructure device, see [Using the Command Line Interface](#).

Using the API

Run the [DeleteImage](#) operation to remove a custom image for use in launching an instance from your Roving Edge Infrastructure devices.

Creating a Custom Image from an Instance for a Roving Edge Infrastructure Device

Describes how to create a custom image from an existing compute instance on your Roving Edge Infrastructure device.

You can create a custom image of a compute instance's boot disk and use that custom image to create other compute instances. Instances that you create from this image include the customizations, configuration, and software that were installed on the boot disk when you created the image. See [Creating an Image from an Instance](#) in the Oracle Cloud Infrastructure Cloud-based help for more information.

Using the Device Console

1. Open the navigation menu and select **Compute > Instances**. The **Instances** page appears. All instances are listed in tabular form.
2. Select a **State** from the list to limit the instances displayed to that state.
3. Click the instance whose details you want to get. The instance's **Details** page appears.
4. Click **More Actions** and select **Create Custom Image** from the menu. The **Create Custom Image** dialog box appears.
5. (optional) Enter a name for the custom image in the **Display Name** box. If you do not enter a name, the Roving Edge Infrastructure device assigns a random name for the custom image.
6. Click **Create Custom Image**. A banner appears indicating either that the request for the custom image is accepted, or it has been rejected for some reason. When the custom image request is being processed, the state of the instance changes to **Creating Image**.
7. Return to the **Instances** page and click **Custom Images**. The **Custom Images** page appears. After the instance is in the available/provisioning state, the **Custom Images** list has the newly created image.
8. Next, open the navigation menu and select **Compute > Custom Images**. The **Custom Images** page appears. All images are listed in tabular form.
9. After the custom image you requested is created, it is listed here. Click it to view its details.

You can launch the custom image you created by clicking the Actions menu (⋮) and selecting **Create Instance**. See [Instances](#) for more information on managing instances of a Roving Edge Infrastructure device.

Using the CLI

Use the `oci compute image create` command and required parameters to create a custom image from an existing compute instance on your Roving Edge Infrastructure devices:

```
oci compute image create --instance-id instance_ocid [OPTIONS]
```

where *instance_ocid* is the OCID of the instance from which you are creating the custom image.

Refer to your Roving Edge Infrastructure device's CLI help for a list of parameters available for this command. See [Accessing Command Line Interface Help](#) on page 53.

For set up information regarding CLIs on your Roving Edge Infrastructure device, see [Using the Command Line Interface](#).

Using the API

Run the [CreateImage](#) operation to create a custom image from an existing compute instance on your Roving Edge Infrastructure devices. Include the `instanceId` attribute which is the OCID of the instance you want to use as the basis for the image.

Exporting a Custom Image to Object Storage for a Roving Edge Infrastructure Device

Describes how to export a custom image to object storage on your Roving Edge Infrastructure device.

Export custom compute images to object service in qcow2 format. The exported images are exported to a specified bucket.

Using the Device Console

1. Open the navigation menu and select **Compute > Images**. The **Custom Images** page appears. All custom images are listed in tabular form.
2. (Optional) Select a **State** from the list to limit the images displayed to that state.
3. Click the image that you want to export to object storage. The image's **Details** page appears.
4. Click **Export**. The **Export Image** dialog box appears.
5. Select the object storage **Bucket** on your Roving Edge Infrastructure device where you want to export the image.
6. Enter the **Name** of the exported image. The image is exported in .qcow2 format.
7. Click **Export Image**.

After you click **Export Image**, the image state changes to **Exporting**. You can still launch instances while the image is exporting, but you can't delete the image until the export has finished. To track the progress of the operation, you can monitor the associated work request. For more information, see [Using the Console to View Work Requests](#) in the Oracle Cloud Infrastructure documentation.

When the export is complete, the image state changes to **Available**. If the image state changes to **Available**, but you do not see the exported image in the object storage bucket location you specified, this means that the export failed, and you will need to go through the steps again to export the image.

Using the CLI

Use the `oci compute image export to-object` command and required parameters to export a custom image to object storage on your Roving Edge Infrastructure devices:

```
oci compute image export to-object --bucket-name bucket_name --image-id image_ociid --namespace rover-namespace [OPTIONS]
```

Refer to your Roving Edge Infrastructure device's CLI help for a list of parameters available for this command. See [Accessing Command Line Interface Help](#) on page 53.

For set up information regarding CLIs on your Roving Edge Infrastructure device, see [Using the Command Line Interface](#).

Using the API

Run the `ExportImage` operation to export a custom image to object storage on your Roving Edge Infrastructure devices

Adding an Image Shape Compatibility Entry to a Roving Edge Infrastructure Device

Describes how to add a shape to the compatible shapes list for the image on your Roving Edge Infrastructure device.

Using the Device Console

1. Open the navigation menu and select **Compute > Images**. The **Custom Images** page appears. All custom images are listed in tabular form.
2. Select a **State** from the list to limit the custom images displayed to that state.
3. Click the custom image whose details you want to get. The custom image's **Details** page appears.
4. Click **Edit Details**.
5. Add and compatible shapes for the custom image.
6. To configure the minimum and maximum number of OCPUs that users can select when they use this image on a flexible shape:

- a. Click the down arrow in the row for the shape.
 - b. Enter the minimum and maximum OCPU counts.
7. Click **Save Changes**.

Note:

After you add shape compatibility to an image, test the image on the shape to ensure that the image actually works on the shape. Some images (especially Windows) might never be cross-compatible with other shapes because of driver or hardware differences.

Using the CLI

Use the `oci compute image-shape-compatibility-entry add` command and required parameters to add a shape to the compatible shapes list for the image on your Roving Edge Infrastructure devices:

```
oci compute image-shape-compatibility-entry add --image-id image_ocid
[OPTIONS]
```

Refer to your Roving Edge Infrastructure device's CLI help for a list of parameters available for this command. See [Accessing Command Line Interface Help](#) on page 53.

For set up information regarding CLIs on your Roving Edge Infrastructure device, see [Using the Command Line Interface](#).

Using the API

Run the `AddImageShapeCompatibilityEntry` operation to add a shape to the compatible shapes list for the image on your Roving Edge Infrastructure devices.

Listing Image Shape Compatibility Entries for a Roving Edge Infrastructure Device

Describes how to list the image shape compatibility entries for the image on your Roving Edge Infrastructure device.

Using the Device Console

1. Open the navigation menu and select **Compute > Images**. The **Custom Images** page appears. All custom images are listed in tabular form.
2. Select a **State** from the list to limit the images displayed to that state.
3. Click the image whose details you want to get. The image's **Details** page appears.
4. Click **Edit Details**. The list of compatible shapes for the image is displayed.

Using the CLI

Use the `oci compute image-shape-compatibility-entry list` command and required parameters to list the image shape compatibility entries for the image on your Roving Edge Infrastructure devices:

```
oci compute image-shape-compatibility-entry list --image-id image_ocid
[OPTIONS]
```

Refer to your Roving Edge Infrastructure device's CLI help for a list of parameters available for this command. See [Accessing Command Line Interface Help](#) on page 53.

For set up information regarding CLIs on your Roving Edge Infrastructure device, see [Using the Command Line Interface](#).

Using the API

Run the `ListImageShapeCompatibilityEntries` operation to list the image shape compatibility entries for the image on your Roving Edge Infrastructure devices.

Getting an Image Shape Compatibility Entry's Details for a Roving Edge Infrastructure Device

Describes how to get the details of an image shape compatibility entry on your Roving Edge Infrastructure device.

Using the Device Console

1. Open the navigation menu and select **Compute > Images**. The **Custom Images** page appears. All custom images are listed in tabular form.
2. Select a **State** from the list to limit the custom images displayed to that state.
3. Click the image whose details you want to get. The image's Details page appears.
4. Click **Edit Details**.
5. Click a compatible shape to get its details.

Using the CLI

Use the `oci compute image-shape-compatibility-entry get` command and required parameters to get the details of an image shape compatibility entry on your Roving Edge Infrastructure devices:

```
oci compute image-shape-compatibility-entry get --image-id image_ocid --  
shape-name shape_name [OPTIONS]
```

Refer to your Roving Edge Infrastructure device's CLI help for a list of parameters available for this command. See [Accessing Command Line Interface Help](#) on page 53.

For set up information regarding CLIs on your Roving Edge Infrastructure device, see [Using the Command Line Interface](#).

Using the API

Run the `GetImageShapeCompatibilityEntry` operation to get the details of an image shape compatibility entry on your Roving Edge Infrastructure devices.

Removing an Image Shape Compatibility Entry from a Roving Edge Infrastructure Device

Describes how to remove an image shape compatibility entry on your Roving Edge Infrastructure device.

Using the Device Console

1. Open the navigation menu and select **Compute > Images**. The **Custom Images** page appears. All custom images are listed in tabular form.
2. Select a **State** from the list to limit the custom images displayed to that state.
3. Click the image entry whose details you want to get. The image's **Details** page appears.
4. Click **Edit Details**.
5. Remove the compatible shape entry.

Using the CLI

Use the `oci compute image-shape-compatibility-entry remove` command and required parameters to remove an image shape compatibility entry on your Roving Edge Infrastructure devices:

```
oci compute image-shape-compatibility-entry remove --image-id image_ocid --  
shape-name shape_name [OPTIONS]
```

Refer to your Roving Edge Infrastructure device's CLI help for a list of parameters available for this command. See [Accessing Command Line Interface Help](#) on page 53.

For set up information regarding CLIs on your Roving Edge Infrastructure device, see [Using the Command Line Interface](#).

Using the API

Run the `RemoveImageShapeCompatibilityEntry` operation to remove an image shape compatibility entry on your Roving Edge Infrastructure devices.

Boot Volumes

Learn about managing boot volume tasks for a compute instance, including creating, updating, and deleting boot volumes, on your Roving Edge Infrastructure devices.

When you launch a virtual machine (VM) instance based on a platform image or custom image, a new boot volume for the instance is created. That boot volume is associated with that instance until you terminate the instance. When you terminate the instance, you can preserve the boot volume and its data.

You can perform the following boot volume management tasks:

- [Creating a Boot Volume](#)
- [Listing Boot Volumes](#)
- [Getting a Boot Volume's Details](#)
- [Renaming a Boot Volume](#)
- [Deleting a Boot Volume](#)
- [Attaching a Boot Volume](#)
- [Listing Boot Volume Attachments](#)
- [Getting a Boot Volume's Attachment Details](#)
- [Detaching a Boot Volume Attachment](#)

You cannot clone boot volumes on a Roving Edge device.

See [Boot Volumes](#) in the Oracle Cloud Infrastructure documentation for more information on this feature.

Creating a Boot Volume for a Compute Instance on a Roving Edge Infrastructure Device

Describes how to create a boot volume for a compute instance on your Roving Edge Infrastructure device.

See [Boot Volumes](#) in the Oracle Cloud Infrastructure documentation for more information on this feature.

Using the CLI

Use the `oci bv boot-volume create` command and required parameters to create a boot volume for a compute instance on your Roving Edge Infrastructure devices:

```
oci bv boot-volume create [OPTIONS]
```

Refer to your Roving Edge Infrastructure device's CLI help for a list of parameters available for this command. See [Accessing Command Line Interface Help](#) on page 53.

For set up information regarding CLIs on your Roving Edge Infrastructure device, see [Using the Command Line Interface](#).

Using the API

Run the `CreateBootVolume` operation to create a boot volume for a compute instance on your Roving Edge Infrastructure devices.

Listing the Boot Volumes for a Compute Instance on a Roving Edge Infrastructure Device

Describes how to list the boot volumes for a compute instance on your Roving Edge Infrastructure device.

See [Listing Boot Volumes](#) in the Oracle Cloud Infrastructure documentation for more information on this feature.

Using the Device Console

1. Open the navigation menu and select **Compute > Instances**. The **Instances** page appears. All instances are listed in tabular form.
2. Select a **State** from the list to limit the instances displayed to that state.
3. Click the instance whose attached boot volumes you want to list. The instance's **Details** page appears.

- Click **Boot Volume** under **Resources**. The **Boot Volumes** page appears, displaying the boot volumes in tabular form.

Using the CLI

Use the `oci bv boot-volume list` command and required parameters to list the boot volumes for a compute instance on your Roving Edge Infrastructure devices:

```
oci bv boot-volume list --compartment-id compartment_ocid --availability-domain orei-1-ad-1 [OPTIONS]
```

To determine your Roving Edge Infrastructure device compartment OCID, see [Compartments](#).

Refer to your Roving Edge Infrastructure device's CLI help for a list of parameters available for this command. See [Accessing Command Line Interface Help](#) on page 53.

For set up information regarding CLIs on your Roving Edge Infrastructure device, see [Using the Command Line Interface](#).

Using the API

Run the `ListBootVolume` operation to list the boot volumes for a compute instance on your Roving Edge Infrastructure devices.

Getting a Boot Volume's Details for a Compute Instance on a Roving Edge Infrastructure Device

Describes how to get the details of a boot volume for a compute instance on your Roving Edge Infrastructure device.

See [Listing Boot Volumes](#) in the Oracle Cloud Infrastructure documentation for more information on this feature.

Using the Device Console

- Open the navigation menu and select **Compute > Instances**. The **Instances** page appears. All instances are listed in tabular form.
- Select a **State** from the list to limit the instances displayed to that state.
- Click the instance on whose attached boot volume you want to get details. The instance's **Details** page appears.
- Click **Boot Volume** under **Resources**. The **Boot Volumes** page appears, displaying the boot volumes in tabular form.
- Click the boot volume on whose details you want to get. The boot volume's **Details** page appears. The instance associated with the boot volume is listed in the **Attached Instance** field. If the value for this field displays the following message, the boot volume has been detached from the associated instance, or the instance has been terminated while the boot volume was preserved.

```
None in this Compartment.
```

Using the CLI

Use the `oci bv boot-volume get` command and required parameters to get the details of a boot volume for a compute instance on your Roving Edge Infrastructure devices:

```
oci bv boot-volume get --boot-volume-id boot_volume_ocid [OPTIONS]
```

Refer to your Roving Edge Infrastructure device's CLI help for a list of parameters available for this command. See [Accessing Command Line Interface Help](#) on page 53.

For set up information regarding CLIs on your Roving Edge Infrastructure device, see [Using the Command Line Interface](#).

Using the API

Run the `GetBootVolume` operation to get the details of a boot volume for a compute instance on your Roving Edge Infrastructure devices.

Renaming a Boot Volume for a Compute Instance on a Roving Edge Infrastructure Device

Describes how to rename a boot volume for a compute instance on your Roving Edge Infrastructure device.

See [Boot Volumes](#) in the Oracle Cloud Infrastructure documentation for more information on this feature.

Using the Device Console

1. Open the navigation menu and select **Compute > Instances**. The **Instances** page appears. All instances are listed in tabular form.
2. Select a **State** from the list to limit the instances displayed to that state.
3. Click the instance whose attached boot volumes you want to rename. The instance's **Details** page appears.
4. Click **Boot Volume** under **Resources**. The **Boot Volumes** page appears, displaying the boot volumes in tabular form.
5. Click the boot volume you want to rename. The **Edit Boot Volume** dialog box appears.
6. Rename the boot volume.
7. Click **Save Changes**.

Using the CLI

Use the `oci bv boot-volume update` command and required parameters to rename a boot volume for a compute instance on your Roving Edge Infrastructure devices:

```
oci bv boot-volume update --boot-volume-id boot_volume_ocid [OPTIONS]
```

Refer to your Roving Edge Infrastructure device's CLI help for a list of parameters available for this command. See [Accessing Command Line Interface Help](#) on page 53.

For set up information regarding CLIs on your Roving Edge Infrastructure device, see [Using the Command Line Interface](#).

Using the API

Run the `UpdateBootVolume` operation to rename a boot volume for a compute instance on your Roving Edge Infrastructure devices.

Deleting a Boot Volume from a Compute Instance on a Roving Edge Infrastructure Device

Describes how to delete a boot volume from a compute instance on your Roving Edge Infrastructure device.

See [Deleting a Boot Volume](#) in the Oracle Cloud Infrastructure documentation for more information on this feature.

Important:

You cannot undo this operation. Any data on a volume is permanently deleted after the volume is deleted. You are not able to restart the associated instance.

Using the Device Console

1. Open the navigation menu and select **Compute > Instances**. The **Instances** page appears. All instances are listed in tabular form.
2. Select a **State** from the list to limit the instances displayed to that state.
3. Click the instance whose attached boot volume you want to delete. The instance's **Details** page appears.
4. Click **Boot Volume** under **Resources**. The **Boot Volumes** page appears, displaying the boot volumes in tabular form.
5. Click the boot volume that you want to delete. The boot volume's **Details** page appears.
6. Click **Terminate**.
7. Confirm the deletion when prompted.

Using the CLI

Use the `oci bv boot-volume delete` command and required parameters to delete a boot volume from a compute instance on your Roving Edge Infrastructure devices:

```
oci bv boot-volume delete --boot-volume-id boot_volume_ocid [OPTIONS]
```

Refer to your Roving Edge Infrastructure device's CLI help for a list of parameters available for this command. See [Accessing Command Line Interface Help](#) on page 53.

For set up information regarding CLIs on your Roving Edge Infrastructure device, see [Using the Command Line Interface](#).

Using the API

Run the `DeleteBootVolume` operation to delete a boot volume from a compute instance on your Roving Edge Infrastructure devices.

Attaching a Boot Volume to a Compute Instance on a Roving Edge Infrastructure Device

Describes how to attach a boot volume to a compute instance on your Roving Edge Infrastructure device.

Note:

You can attach a boot volume only to a stopped compute instance.

Using the Device Console

1. Open the navigation menu and select **Compute > Instances**. The **Instances** page appears. All instances are listed in tabular form.
2. Select a **State** from the list to limit the instances displayed to that state.
3. Click the instance to which you want to attach the boot volume. The instance's **Details** page appears.
4. Click **Boot Volume** under **Resources**. The **Boot Volumes** page appears, displaying the boot volumes in tabular form.
5. Click the Actions menu (⋮) and click **Attach Boot Volume**. Confirm when prompted.

You can start the instance when the boot volume's state is **Attached**.

Using the CLI

Use the `oci compute boot-volume-attachment attach` command and required parameters to attach a boot volume to a compute instance on your Roving Edge Infrastructure devices:

```
oci compute boot-volume-attachment attach --boot-volume-id boot_volume_ocid  
--instance-id instance_ocid [OPTIONS]
```

Refer to your Roving Edge Infrastructure device's CLI help for a list of parameters available for this command. See [Accessing Command Line Interface Help](#) on page 53.

For set up information regarding CLIs on your Roving Edge Infrastructure device, see [Using the Command Line Interface](#).

Using the API

Run the `AttachBootVolume` operation to attach a boot volume to a compute instance on your Roving Edge Infrastructure devices.

Listing the Attached Instances for a Boot Volume on a Roving Edge Infrastructure Device

Describes how to list the attached instances on a boot volume for a compute instance on your Roving Edge Infrastructure device.

Using the Device Console

1. Open the navigation menu and select **Compute > Instances**. The **Instances** page appears. All instances are listed in tabular form.
2. Select a **State** from the list to limit the boot volumes displayed to that state.
3. Click the instance whose attached boot volumes you want to list. The instance's **Details** page appears.
4. Click **Boot Volume** under **Resources**. The **Boot Volumes** page appears, displaying the boot volumes in tabular form.
5. Click the boot volume whose attachments you want to list. The boot volume's **Details** page appears.
6. Click **Attached Instances** under **Resources**. The **Attached Instances** page appears. All attached instances are displayed in tabular form.

Using the CLI

Use the `oci compute boot-volume-attachment list` command and required parameters to list the boot volumes attachments for a compute instance on your Roving Edge Infrastructure devices:

```
oci compute boot-volume-attachment list --compartment-id compartment_ocid --availability-domain orei-1-ad-1 [OPTIONS]
```

To determine your Roving Edge Infrastructure device compartment OCID, see [Compartments](#).

Refer to your Roving Edge Infrastructure device's CLI help for a list of parameters available for this command. See [Accessing Command Line Interface Help](#) on page 53.

For set up information regarding CLIs on your Roving Edge Infrastructure device, see [Using the Command Line Interface](#).

Using the API

Run the `ListBootVolumeAttachments` operation to list the boot volumes attachments for a compute instance on your Roving Edge Infrastructure devices.

Getting a Boot Volume Attachment's Details for a Computer Instance on a Roving Edge Infrastructure Device

Describes how to get the details of a boot volume attachment for a compute instance on your Roving Edge Infrastructure device.

Using the Device Console

1. Open the navigation menu and select **Compute > Instances**. The **Instances** page appears. All instances are listed in tabular form.
2. Select a **State** from the list to limit the boot volumes displayed to that state.
3. Click the instance whose attached boot volumes you want to list. The instance's **Details** page appears.
4. Click **Boot Volume** under **Resources**. The **Boot Volumes** page appears, displaying the boot volumes in tabular form.
5. Click the boot volume whose attachments you want to list. The boot volume's **Details** page appears.
6. Click **Attached Instances** under **Resources**. The **Attached Instances** page appears. All attached instances are displayed in tabular form.

Using the CLI

Use the `oci compute boot-volume-attachment get` command and required parameters to get the details of a boot volume attachment for a compute instance on your Roving Edge Infrastructure devices:

```
oci compute boot-volume-attachment get --boot-volume-attachment-id boot_volume_attachment_ocid [OPTIONS]
```

Refer to your Roving Edge Infrastructure device's CLI help for a list of parameters available for this command. See [Accessing Command Line Interface Help](#) on page 53.

For set up information regarding CLIs on your Roving Edge Infrastructure device, see [Using the Command Line Interface](#).

Using the API

Run the `GetBootVolumeAttachment` operation to get the details of a boot volume attachment for a compute instance on your Roving Edge Infrastructure devices.

Detaching a Boot Volume Attachment from a Compute Instance on a Roving Edge Infrastructure Device

Describes how to detach a boot volume from a compute instance on your Roving Edge Infrastructure device.

Note:

You can detach a boot volume only from a stopped compute instance.

Using the Device Console

1. Open the navigation menu and select **Compute > Instances**. The **Instances** page appears. All instances are listed in tabular form.
2. Select a **State** from the list to limit the instances displayed to that state.
3. Click the instance from which you want to detach the boot volume. The instance's **Details** page appears.
4. Click **Boot Volume** under **Resources**. The **Boot Volumes** page appears, displaying the boot volumes in tabular form.
5. Click the Actions menu (⋮) for the boot volume, and then click **Detach Boot Volume**. Confirm when prompted.

Using the CLI

Use the `oci compute boot-volume-attachment detach` command and required parameters to detach a boot volume from a compute instance on your Roving Edge Infrastructure devices:

```
oci compute boot-volume-attachment detach --boot-volume-attachment-id boot_volume_attachment_ocid [OPTIONS]
```

Refer to your Roving Edge Infrastructure device's CLI help for a list of parameters available for this command. See [Accessing Command Line Interface Help](#) on page 53.

For set up information regarding CLIs on your Roving Edge Infrastructure device, see [Using the Command Line Interface](#).

Using the API

Run the `DetachBootVolume` operation to detach a boot volume from a compute instance on your Roving Edge Infrastructure devices.

Console History Capture

Describes how to manage the console history captures, including capturing, updating, and deleting console history captures, on your devices.

You can perform the following console history capture management tasks:

- [Capturing a Console History](#)
- [Listing Console History Captures](#)
- [Getting a Console History's Metadata Details](#)
- [Getting a Console History's Content Details](#)
- [Editing a Console History's Metadata](#)
- [Deleting a Console History Capture](#)

See [Displaying the Console for an Instance](#) in the Oracle Cloud Infrastructure documentation for more information on this feature.

Note:

Console history capture is only available using CLI and API.

Capturing a Console History

Describes how to capture the console history on your Roving Edge Infrastructure devices.

Using the Device Console

This task can't be performed using the Device Console.

Using the CLI

Use the `oci compute console-history capture` command and required parameters to capture the console history on your Roving Edge Infrastructure devices:

```
oci compute console-history capture --instance-id instance_ocid [OPTIONS]
```

Refer to your Roving Edge Infrastructure device's CLI help for a list of parameters available for this command. See [Accessing Command Line Interface Help](#) on page 53.

For set up information regarding CLIs on your Roving Edge Infrastructure device, see [Using the Command Line Interface](#).

Using the API

Run the `CaptureConsoleHistory` operation to capture the console history on your Roving Edge Infrastructure devices.

Listing Console History Captures

Describes how to list the console history captures on your Roving Edge Infrastructure devices.

Using the Device Console

This task can't be performed using the Device Console.

Using the CLI

Use the `oci compute console-history list` command and required parameters to list the console history captures on your Roving Edge Infrastructure devices:

```
oci compute console-history list --compartment-id compartment_ocid [OPTIONS]
```

To determine your Roving Edge Infrastructure device compartment OCID, see [Compartments](#).

For a complete list of flags and variable options for CLI commands, see the [Command Line Reference](#).

For set up information regarding CLIs on your Roving Edge Infrastructure device, see [Using the Command Line Interface](#).

Using the API

Run the `ListConsoleHistories` operation to list the console history captures on your Roving Edge Infrastructure devices.

Getting a Console History Capture's Metadata Details

Describes how to get the metadata details of a console history capture on your Roving Edge Infrastructure devices.

Using the Device Console

This task can't be performed using the Device Console.

Using the CLI

Use the `oci compute console-history get` command and required parameters to get the metadata details of a console history capture on your Roving Edge Infrastructure devices:

```
oci compute console-history get --instance-console-history-id instance_console_history_ocid [OPTIONS]
```

Refer to your Roving Edge Infrastructure device's CLI help for a list of parameters available for this command. See [Accessing Command Line Interface Help](#) on page 53.

For set up information regarding CLIs on your Roving Edge Infrastructure device, see [Using the Command Line Interface](#).

Using the API

Run the `GetConsoleHistory` operation to get the metadata details of a console history capture on your Roving Edge Infrastructure devices.

Getting a Console History Capture's Content Details

Describes how to get the content details of a console history capture on your Roving Edge Infrastructure devices.

Using the Device Console

This task can't be performed using the Device Console.

Using the CLI

Use the `oci compute console-history get-content` command and required parameters to get the content details of a console history capture on your Roving Edge Infrastructure devices:

```
oci compute console-history get-content --file file --instance-console-history-id instance_console_history_ocid [OPTIONS]
```

Refer to your Roving Edge Infrastructure device's CLI help for a list of parameters available for this command. See [Accessing Command Line Interface Help](#) on page 53.

For set up information regarding CLIs on your Roving Edge Infrastructure device, see [Using the Command Line Interface](#).

Using the API

Run the `GetConsoleHistoryContent` operation to get the content details of a console history capture on your Roving Edge Infrastructure devices.

Editing a Console History's Metadata

Describes how to update metadata of a console history capture on your Roving Edge Infrastructure devices.

Using the Device Console

This task can't be performed using the Device Console.

Using the CLI

Use the `oci compute console-history update` command and required parameters to update metadata of a console history capture on your Roving Edge Infrastructure devices:

```
oci compute console-history update --instance-console-history-id instance_console_history_ocid [OPTIONS]
```

Refer to your Roving Edge Infrastructure device's CLI help for a list of parameters available for this command. See [Accessing Command Line Interface Help](#) on page 53.

For set up information regarding CLIs on your Roving Edge Infrastructure device, see [Using the Command Line Interface](#).

Using the API

Run the [UpdateConsoleHistory](#) operation to update metadata of a console history capture on your Roving Edge Infrastructure devices.

Deleting a Console History Capture

Describes how to delete a console history capture on your Roving Edge Infrastructure devices.

Using the Device Console

This task can't be performed using the Device Console.

Using the CLI

Use the [oci compute console-history delete](#) command and required parameters to delete a console history capture on your Roving Edge Infrastructure devices:

```
oci compute console-history delete --instance-console-history-id instance_console_history_ocid [OPTIONS]
```

Refer to your Roving Edge Infrastructure device's CLI help for a list of parameters available for this command. See [Accessing Command Line Interface Help](#) on page 53.

For set up information regarding CLIs on your Roving Edge Infrastructure device, see [Using the Command Line Interface](#).

Using the API

Run the [DeleteConsoleHistory](#) operation to delete a console history capture on your Roving Edge Infrastructure devices.

Object Storage for Roving Edge Infrastructure

Describes how to manage object storage tasks, including those for buckets and objects, on your Roving Edge Infrastructure devices.

This section describes the following Roving Edge Infrastructure on-device services related to object storage:

- [Buckets](#)
- [Objects](#)

Performance and Usage Thresholds

We recommend that you keep your storage thresholds below 80%. Maintaining this level is important to optimize performance, especially for intensive writing operations. If the Roving Edge Infrastructure device capacity nears 80%, transfer data to your OCI tenancy until the storage level falls below 80% to achieve optimal operation of services.

Regularly monitor the available storage space for all your Roving Edge Infrastructure devices. See [Roving Edge Infrastructure Device Monitoring](#) on page 148.

Amazon S3 Compatibility API

Using the Amazon S3 Compatibility API, customers can continue to use their existing Amazon S3 tools (for example, SDK clients) and make minimal changes to their applications to work with Object Storage. The Amazon S3 Compatibility API and Object Storage datasets are congruent. If data is written to the Object Storage using the Amazon S3 Compatibility API, the data can be read back using the native Object Storage API and conversely.

Differences between the Object Storage API and the Amazon S3 Compatibility API

The Object Storage service provided by Oracle Cloud Infrastructure and Amazon S3 use similar concepts and terminology. In both cases, data is stored as objects in buckets. The differences are in the implementation of features and tools for working with objects.

The following highlights the differences between the two storage technologies:

- **Compartments**

Amazon S3 does not use compartments. By default, buckets created using the Amazon S3 Compatibility API or the Swift API are created in the root compartment of the Oracle Cloud Infrastructure tenancy. Instead, you can designate a different compartment for the Amazon S3 Compatibility API or Swift API to create buckets in.

- **Global bucket namespace**

Object Storage does not use a global bucket namespace. Instead, the namespace serves as the top-level container for all buckets and objects. At account creation time, each tenant is assigned one unique system-generated and immutable namespace name. The namespace spans all compartments within a region. You control bucket names, but those bucket names must be unique within a namespace. While the namespace is region-specific, the namespace name itself is the same in all regions. You can have a bucket named **MyBucket** in US West (Phoenix) and a bucket named **MyBucket** in Germany Central (Frankfurt).

- **Encryption**

The Object Storage service encrypts all data at rest by default. Encryption can't be turned on or off using the API.

- **Object Level Access Control Lists (ACLs)**

Oracle Cloud Infrastructure does not use ACLs for objects. Instead, an administrator needs to set up *groups*, *compartments*, and *policies* that control which users can access which services, which resources, and the type of access. For example, the policies control who can create users and groups, create buckets, download objects, and manage Object Storage-related policies and rules.

For more information, see [Overview of Object Storage](#).

Setting up Access to Oracle Cloud Infrastructure

To enable application access from Amazon S3 to Object Storage, you need to set up access to Oracle Cloud Infrastructure and modify your application.

1. Sign up for Oracle Cloud Infrastructure and obtain a unique namespace.
2. Any user of the Amazon S3 Compatibility API with Object Storage needs permission to work with the service. If you are not sure if you have permission, contact your administrator. For basic information about policies, see [How Policies Work](#). For policies that enable use of Object Storage, see [Common Policies](#) and the [Policy Reference](#).
3. Use an existing or create a customer secret key. A customer secret key consists of an access key/secret key pair. The creation and use of these keys is described in the following section on setting up the S3 configuration file.

Setting Up the S3 Configuration File

Object Storage on Roving Edge Infrastructure supports the Amazon S3cmd tool in addition to supporting the Oracle Cloud Infrastructure command line interface. Support of the Amazon S3cmd tool requires you to set up the S3 configuration file but also supports S3cmd.

You can download s3cmd from the following site:

<https://s3tools.org/download>

On Macintosh and Linux, the s3cmd configuration file is named `.s3cfg` and it is located in the your home directory, for example:

```
/home/username/ ($HOME)
```

On Windows, the s3cmd configuration file is named `s3cmd.ini` and it is located in `%USERPROFILE% -> Application Data`, which is typically the following:

```
c:\users\username\AppData\Roaming\s3cmd.ini
```

For more details, reference: <https://s3tools.org/kb/item14.htm>

The following example shows contents the S3cmd configuration file:

```
[default]
access_key = 9aa40ec9-bec3-4fab-9e5a-3584a5979d48
access_token =
add_encoding_exts =
add_headers =
bucket_location = US
cache_file =
ca_certs_file = <Full path to the bundle.pem file>
check_ssl_hostname = False
default_mime_type = binary/octet-stream
delay_updates = False
delete_after = False
delete_after_fetch = False
delete_removed = False
dry_run = False
enable_multipart = True
encoding = UTF-8
encrypt = False
expiry_date =
expiry_days =
expiry_prefix =
follow_symlinks = False
force = False
get_continue = False
gpg_command = /usr/bin/gpg
gpg_decrypt = %(gpg_command)s -d --verbose --no-use-agent --batch --yes --
passphrase-fd %(passphrase_fd)s -o %(output_file)s %(input_file)s
gpg_encrypt = %(gpg_command)s -c --verbose --no-use-agent --batch --yes --
passphrase-fd %(passphrase_fd)s -o %(output_file)s %(input_file)s
gpg_passphrase =
guess_mime_type = True
host_base = <rover_node_ip>:8019
host_bucket = <rover_node_ip>:8019
human_readable_sizes = False
ignore_failed_copy = False
invalidate_default_index_on_cf = False
invalidate_default_index_root_on_cf = True
invalidate_on_cf = False
list_md5 = False
log_target_prefix =
max_delete = -1
mime_type =
multipart_chunk_size_mb = 15
preserve_attrs = True
progress_meter = True
proxy_host =
proxy_port = 0
put_continue = False
recursive = False
recv_chunk = 4096
reduced_redundancy = False
restore_days = 1
secret_key = <Your secret key, see below>
send_chunk = 4096
server_side_encryption = False
skip_existing = False
socket_timeout = 300
urlencoding_mode = normal
use_https = True
use_mime_magic = True
verbosity = WARNING
```

```
website_endpoint = https://<rover_node_ip>:8015
website_error =
```

To set up the S3cmd configuration file for use with Roving Edge Infrastructure:

1. Update the **access_key** field:

- a. Log into the Roving Edge Infrastructure Device Console of the appropriate device.
- b. Open the navigation menu and select **Identity Management > Users**. The **Users** page appears. All users are listed in tabular form.
- c. Click the user whose access key you want to use in the S3cmd configuration file. The user's **Details** page appears.
- d. Click **Customer Secret Keys** under **Resources**. The **Customer Secret Keys** page appears. All customer secret keys are listed in tabular form.
- e. Copy the access key and past it into the **access_key** field value in the s3cmd configuration file.

2. Update the **ca_certs_file** field: Enter the full path of your `bundle.pem` file, for example:

```
/Users/user_name/.oci/bundle.pem
```

If you do not have the ca certs file, download it using the following command:

```
echo -n | openssl s_client -showcerts -connect rover_node_IP:8015 |
sed -ne '/-BEGIN CERTIFICATE-/,/-END CERTIFICATE-/p' > bundle.pem
```

3. Set the **check_ssl_hostname** field to `false`.

4. Update the **host_base** field: Enter the `rover_node_IP:8019`.

5. Update the **host_bucket** field: Enter the `rover_node_IP:8019`.

6. Update the **secret_key** field:

- a. Log into the Roving Edge Infrastructure Device Console of the appropriate device.
- b. Open the navigation menu and select **Identity Management > Users**. The **Users** page appears. All users are listed in tabular form.
- c. Click the user whose secret key you want to use in the S3cmd configuration file. The user's **Details** page appears.
- d. Click **Customer Secret Keys** under **Resources**. The **Customer Secret Keys** page appears. All customer secret keys are listed in tabular form.
- e. Click **Generate Secret Key**. The generated **Secret Key** is displayed in the **Generate Secret Key** dialog box. At the same time, Oracle generates the **Access Key** that is paired with the **Secret Key**. The newly generated Customer Secret key is added to the list of **Customer Secret Keys**.
- f. Copy the key and past it into the **secret_key** field value in the s3cmd configuration file.

7. Save and close the s3cmd configuration file.

Amazon S3 Compatibility API Support

Amazon S3 Compatibility API support is provided at the bucket level and object level.

Bucket APIs

The following bucket APIs are supported:

- [DeleteBucket](#)
- [HeadBucket](#)
- [GetService](#) (list all my buckets)
- [ListObjects](#)
- [PutBucket](#)

Object APIs

The following object APIs are supported:

- [BulkDelete](#)
- [DeleteObject](#)
- [GetObject](#)
- [HeadObject](#)
- [PutObject](#)

Multipart Upload APIs

The following multipart upload APIs are supported:

- [AbortMultipartUpload](#)
- [CompleteMultipartUpload](#)
- [InitiateMultipartUpload](#)
- [ListParts](#)
- [ListUploads](#)
- [UploadPart](#)

SSE-C Support

Using optional API headers, you can provide your own 256-bit AES encryption key that is used to encrypt and decrypt objects uploaded to and downloaded from Object Storage.

If you want to use your own keys for server-side encryption, specify the following three request headers with the encryption key information:

Headers	Description	APIs Supported
x-amz-server-side-encryption-customer-algorithm	Specifies "AES256" as the encryption algorithm.	GetObject HeadObject PutObject InitiateMultipartUpload UploadPart
x-amz-server-side-encryption-customer-key	Specifies the base64-encoded 256-bit encryption key to use to encrypt or decrypt the data.	
x-amz-server-side-encryption-customer-key-md5	Specifies the base64-encoded 128-bit MD5 digest of the encryption key. This value is used to check the integrity of the encryption key.	

Object Storage has distinct APIs for copying objects and copying parts. Amazon S3 uses the presence of the following headers in [PutObject](#) and [UploadPart](#) to determine copy operations. To copy a source object that is encrypted with an SSE-C key, you must specify these three headers so that Object Storage can decrypt the object.

Headers	Description	APIs Supported
x-amz-copy-source-server-side-encryption-customer-algorithm	Specifies "AES256" as the encryption algorithm to use to decrypt the source object.	PutObject UploadPart
x-amz-copy-source-server-side-encryption-customer-key	Specifies the base64-encoded 256-bit encryption key to use to decrypt the source object.	
x-amz-copy-source-server-side-encryption-customer-key-md5	Specifies the base64-encoded 128-bit MD5 digest of the encryption key used to decrypt the source object.	

Support for Encryption Using Your Own Keys in Vault

Using optional API headers, you can provide your own encryption key in Vault that is used to encrypt objects uploaded to Object Storage.

If you want to use your own keys in Vault for server-side encryption, specify the following request header with the OCID of the key in Vault:

Headers	Description	APIs Supported
x-amz-server-side-encryption-aws-kms-key-id	OCID of an existing key in Vault to be used to encrypt the object.	PutObject InitiateMultipartUpload UploadPart

Supported Amazon S3 Clients

You can configure various client applications to talk to Object Storage's Amazon S3-compatible endpoints. This topic provides some configuration examples for supported Amazon S3 Clients. Review the prerequisites in [Setting up Access to Oracle Cloud Infrastructure](#) on page 220.

AWS SDK for Java

The AWS SDK for Java repository, file download, and documentation links are available on GitHub: <https://github.com/aws/aws-sdk-java>.

Here is an example of configuring AWS SDK for Java to use Object Storage

```

// Put the Access Key and Secret Key here

AWSCredentialsProvider credentials = new AWSStaticCredentialsProvider(new
    BasicAWSCredentials(
        "gQ4+YC530sBa8qZI6WcbUbtH8oar0exampleuniqueID",
        "7fa22331ebe62bf4605dc9a42aaexampleuniqueID" ));

// Your namespace
String namespace = "rover-namespace";

// The region to connect to
String region = "us-ashburn-1";

// Create an S3 client pointing at the region
String endpoint = String.format("%s.compat.objectstorage.
%s.oraclecloud.com", namespace, region);
AWSClientBuilder.EndpointConfiguration endpointConfiguration = new
    AWSClientBuilder.EndpointConfiguration(endpoint, region);
AmazonS3 client = AmazonS3Client.builder()
    .standard()
    .withCredentials(credentials)
    .withEndpointConfiguration(endpointConfiguration)
    .disableChunkedEncoding()
    .enablePathStyleAccess()
    .build();

```

AWS SDK for Javascript

The AWS SDK for Javascript repository, documentation links, and installation instructions are available on GitHub: <https://github.com/aws/aws-sdk-js>.

Here is an example of configuring AWS SDK for Javascript to use Object Storage

```
s3 = new AWS.S3({
  region: 'us-ashburn-1',
  endpoint: 'https://' + rover-namespace + '.compat.objectstorage.us-
ashburn-1.oraclecloud.com',
  accessKeyId: 'gQ4+YC530sBa8qZI6WcbUbtH8oar0exampleuniqueID',
  secretAccessKey: '7fa22331ebe62bf4605dc9a42aaexampleuniqueID',
  s3ForcePathStyle: true,
  signatureVersion: 'v4',
});
```

AWS SDK for Python (Boto3)

The AWS SDK for Python (Boto3) repository, documentation links, and installation instructions are available on GitHub: <https://github.com/boto/boto3>.

Here is an example of configuring AWS SDK for Python to use Object Storage

```
import boto3

s3 = boto3.resource(
    's3',
    aws_access_key_id="gQ4+YC530sBa8qZI6WcbUbtH8oar0exampleuniqueID",
    aws_secret_access_key="7fa22331ebe62bf4605dc9a42aaexampleuniqueID",
    region_name="us-phoenix-1", # Region name here that matches the endpoint
    endpoint_url="https://rover-namespace.compat.objectstorage.us-
phoenix-1.oraclecloud.com" # Include your rover-namespace in the URL
)

# Print out the bucket names
for bucket in s3.buckets.all():
    print bucket.name
```

Mounting Object Storage buckets using s3fs

s3fs lets Linux and macOS mount Object Storage as a file system. The s3fs repository, documentation links, installation instructions, and examples are available on GitHub: <https://github.com/s3fs-fuse/s3fs-fuse>.

s3fs is not suitable for all applications. Understand the following limitations:

- Object storage services have high latency compared to local file systems for time to first-byte and lack random write access. s3fs achieves the best throughput on workloads that only read large files.
- You cannot partially update a file, so changing a single byte requires uploading the entire file.
- Random writes or appends to files require rewriting the entire file.
- s3fs does not support partial downloads, so even if you only want to read one byte of a file, you need to download the entire file.
- s3fs does not support server-side file copies. Copied files must first be downloaded to the client and then uploaded to the new location.
- Metadata operations, such as listing directories, have poor performance because of network latency.
- s3fs does not support hard links or the atomic renames of files or directories.
- s3fs provides no coordination between multiple clients mounting the same bucket.

To mount an Object Storage bucket as a file system:

1. Follow the installation instructions provided on GitHub: <https://github.com/s3fs-fuse/s3fs-fuse>.

If you are unable to install using a pre-built package, follow the compilation instructions here: <https://github.com/s3fs-fuse/s3fs-fuse/blob/master/COMPILATION.md>.

- Review and perform the prerequisites in [Setting up Access to Oracle Cloud Infrastructure](#) on page 220. You need an Access Key/Secret Key pair and a proper IAM policy that lets you mount a bucket as a file system. For example:

```
Allow group s3fsAdmins to manage object-family in tenancy
```

- Enter your Access Key/Secret Key pair credentials in a `/${HOME}/.passwd-s3fs` credential file:

```
cat ${HOME}/.passwd-s3fs
access_key:secret_key
```

For example:

```
cat ${HOME}/.passwd-s3fs
gQ4+YC530sBa8qZI6WcbUbtH8oar0exampleuniqueID:7fa22331ebe62bf4605dc9a42aaexampleunique
```

Then, set owner-only permissions for the credential file:

```
chmod 600 ${HOME}/.passwd-s3fs
```

- Create a mount point to mount an Object Storage bucket:

```
mkdir /path/to/local_directory_name
s3fs bucket_name local_directory_name -o passwd_file=${HOME}/.passwd-s3fs
-o url=https://rover-
namespace.compat.objectstorage.region_ID.oraclecloud.com
-o use_path_request_style -o kernel_cache -o multipart_size=128 -o
parallel_count=50 -o multireq_max=100 -o max_background=1000
[-o endpoint=region_ID]
```

Where:

- `bucket_name` is the name of the bucket that you want to mount.
 - `local_directory_name` is the name of the local directory where you want to mount the bucket.
 - `namespace_name` is the unique system-generated assigned to your tenancy at account creation time. You can use the CLI or the Console to obtain your namespace name. See [Understanding Object Storage Namespaces](#) for details.
 - `region_ID` is the region identifier where the bucket resides. See [Regions and Availability Domains](#) for details.
 - `endpoint`: If you want to mount a bucket that was created in your home region, you do not need to specify the endpoint parameter. If you want to mount a bucket that was created in a different region, you need to specify the endpoint parameter.
- If you want to automatically mount the bucket as a file system on system startup using s3fs, add following to the `/etc/fstab` file:

```
bucket_name /path/to/local_directory_name fuse.
s3fs use_path_request_style,passwd_file=/root/.s3fs-
password,url=https://rover-namespace.
compat.objectstorage.region_ID.oraclecloud.com,endpoint=region_ID
kernel_cache,multipart_size=128,parallel_count=50,multireq_max=100,max_background=1000
```

- To verify the s3fs bucket mount, run the `df -h` command. The output shows the new mount point for the bucket. Navigate to the new mount point and run the `ls` command to list all objects in the bucket.

To troubleshoot mounting an Object Storage bucket

- If you get authorization errors, review your IAM policies and ensure you have one that lets you mount a bucket as a file system. For example:

```
Allow group s3fsAdmins to manage object-family in tenancy
```

- If you are trying to mount a bucket that was created in a region other than your home region, you need to specify that other region in both the `url` and `endpoint` parameters.
- If you mount a bucket as the root user, other users are not able to list or access objects in the bucket unless you add `-o allow_other` to the `s3fs` command or `allow_other` to the `/etc/fstab` mount options. You can also supply specific UID and GID parameters to specify user access details.
- If you reviewed and verified the troubleshooting solutions and need to contact Support, run the mount command again in DEBUG mode to get more failure details. Add the following to the end of the command and save the output:

```
-o dbglevel=info -f -o curldbg
```

To unmount an Object Storage bucket from a file system, run the following command, specifying the mount point:

```
umount /path/to/local_directory_name
```

Buckets

Learn about managing the Object Storage bucket tasks, including creating, updating, and deleting buckets, on your Roving Edge Infrastructure devices.

You can perform the bucket management tasks:

- [Creating a Bucket](#)
- [Listing Buckets](#)
- [Getting a Bucket's Details](#)
- [Deleting a Bucket](#)

See [Managing Buckets](#) in the Oracle Cloud Infrastructure documentation for more information on this feature.

Creating a Bucket

Describes how to create a object storage bucket on your Roving Edge Infrastructure devices.

Using the Device Console

1. Open the navigation menu and select **Storage > Object Storage & Archive Storage**. The **Buckets** page appears. All buckets are listed in tabular form.
2. Click **Create Bucket**. The **Create Bucket** dialog box appears.
3. Enter a name in the **Bucket Name** box. The system generates a default bucket name that reflects the current year, month, day, and time, for example **bucket-20190306-1359**. If you change this default to any other bucket name, use letters, numbers, dashes, underscores, and periods. Avoid entering confidential information.
4. Select **Enable Object Versioning** if you want to apply versioning to all objects that you upload. See [Object Versioning](#).
5. Click **Create**.

The bucket is created and you can start uploading objects.

Using the CLI

Use the `oci os bucket create` command and required parameters to create a object storage bucket on your Roving Edge Infrastructure devices:

```
oci os bucket create --compartment_id compartment_ocid --name name [OPTIONS]
```

For example:

```
oci os bucket create --name sample_test_bucket
{
  "data": {
    "approximate-count": null,
    "approximate-size": null,
```

```

    "auto-tiering": null,
    "compartment-id": "ocidl.tenancy.orei..exampleuniqueID",
    "created-by": null,
    "defined-tags": null,
    "etag": "87b5810e-ae30-4b02-a5cd-6eede4233259",
    "freeform-tags": null,
    "id": "ocidl.bucket.orei.orei-1..exampleuniqueID",
    "is-read-only": null,
    "kms-key-id": null,
    "metadata": null,
    "name": "sample_test_bucket",
    "namespace": "rover-namespace",
    "object-events-enabled": null,
    "object-lifecycle-policy-etag": null,
    "public-access-type": null,
    "replication-enabled": null,
    "storage-tier": null,
    "time-created": "2023-06-02T12:40:22.195000+00:00",
    "versioning": "Disabled"
  },
  "etag": "87b5810e-ae30-4b02-a5cd-6eede4233259"
}

```

To determine your Roving Edge Infrastructure device compartment OCID, see [Compartments](#).

Refer to your Roving Edge Infrastructure device's CLI help for a list of parameters available for this command. See [Accessing Command Line Interface Help](#) on page 53.

For set up information regarding CLIs on your Roving Edge Infrastructure device, see [Using the Command Line Interface](#).

Using the API

Run the [CreateBucket](#) operation to create an object storage bucket on your Roving Edge Infrastructure devices.

Listing Buckets

Describes how to list the object storage buckets on your Roving Edge Infrastructure devices.

Note:

The list contains only summary fields for the bucket and does not contain fields like the user-defined metadata.

Using the Device Console

Open the navigation menu and select **Storage > Object Storage & Archive Storage**. The **Buckets** page appears. All buckets are listed in tabular form.

Using the CLI

Use the [oci os bucket list](#) command and required parameters to list the object storage buckets on your Roving Edge Infrastructure devices:

```
oci os bucket list --compartment-id compartment_ocid [OPTIONS]
```

For example:

```

oci os bucket list
{
  "data": [
    {
      "compartment-id": "ocidl.tenancy.orei..exampleuniqueID",
      "created-by": "First User",
      "defined-tags": null,

```

```

    "etag": "72d614f7-618c-476b-8d4d-41f8ee354083",
    "freeform-tags": null,
    "name": "provisioned-oci-custom-images",
    "namespace": "rover-namespace",
    "time-created": "2023-05-15T08:41:16.430000+00:00"
  },
  {
    "compartment-id": "ocidl.tenancy.orei..exampleuniqueID",
    "created-by": "First User",
    "defined-tags": null,
    "etag": "76ef7213-1118-4748-97f7-09738f9f353b",
    "freeform-tags": null,
    "name": "rover-system-upgrade-staging",
    "namespace": "rover-namespace",
    "time-created": "2023-05-15T08:32:19.484000+00:00"
  }
],
"opc-next-page": "rover-system-upgrade-staging"
}

```

To determine your Roving Edge Infrastructure device compartment OCID, see [Compartments](#).

Refer to your Roving Edge Infrastructure device's CLI help for a list of parameters available for this command. See [Accessing Command Line Interface Help](#) on page 53.

For set up information regarding CLIs on your Roving Edge Infrastructure device, see [Using the Command Line Interface](#).

Using the API

Run the [ListBuckets](#) operation to list the object storage buckets on your Roving Edge Infrastructure devices.

Getting a Bucket's Details

Describes how to get the details of an object storage bucket on your Roving Edge Infrastructure devices.

Using the Device Console

1. Open the navigation menu and select **Storage > Object Storage & Archive Storage**. The **Buckets** page appears. All buckets are listed in tabular form.
2. Click the bucket whose details you want to get. The bucket's **Details** page appears.

Using the CLI

Use the [oci os bucket get](#) command and required parameters to get the details of an object storage bucket on your Roving Edge Infrastructure devices:

```
oci os bucket get --bucket-name bucket_name [OPTIONS]
```

For example:

```

oci os bucket get --bucket-name my_bucket
{
  "data": {
    "approximate-count": null,
    "approximate-size": null,
    "auto-tiering": null,
    "compartment-id": "ocidl.tenancy.orei..exampleuniqueID",
    "created-by": null,
    "defined-tags": null,
    "etag": "3a4abblc-0d4d-4760-b756-2fb69f46b73f",
    "freeform-tags": null,
    "id": "ocidl.bucket.orei.orei-1..exampleuniqueID",
    "is-read-only": null,
    "kms-key-id": null,

```

```

    "metadata": null,
    "name": "os_test",
    "namespace": "rover-namespace",
    "object-events-enabled": null,
    "object-lifecycle-policy-etag": null,
    "public-access-type": null,
    "replication-enabled": null,
    "storage-tier": null,
    "time-created": "2023-05-30T05:21:33+00:00",
    "versioning": "Disabled"
  },
  "etag": "3a4abb1c-0d4d-4760-b756-2fb69f46b73f"
}

```

Refer to your Roving Edge Infrastructure device's CLI help for a list of parameters available for this command. See [Accessing Command Line Interface Help](#) on page 53.

For set up information regarding CLIs on your Roving Edge Infrastructure device, see [Using the Command Line Interface](#).

Using the API

Run the [GetBucket](#) operation to get the details of an object storage bucket on your Roving Edge Infrastructure devices.

Deleting a Bucket

Describes how to delete an object storage bucket on your Roving Edge Infrastructure devices.

The bucket must be empty before you can delete it. See [Deleting an Object](#). If your bucket has versioning enabled, you must delete each version of all the objects contained in the bucket before you can delete the bucket. See [Deleting an Object Version](#).

Using the Device Console

1. Open the navigation menu and select **Storage > Object Storage & Archive Storage**. The **Buckets** page appears. All buckets are listed in tabular form.
2. Click the bucket that you want to delete. The bucket's **Details** page appears.
3. Click **Delete**.
4. Confirm the deletion when prompted.

Using the CLI

Use the [oci os bucket delete](#) command and required parameters to delete an object storage bucket on your Roving Edge Infrastructure devices:

```
oci os bucket delete --bucket-name bucket_name [OPTIONS]
```

For example:

```
oci os bucket delete --bucket-name my_bucket
Are you sure you want to delete this bucket? [y/N]: y
```

Refer to your Roving Edge Infrastructure device's CLI help for a list of parameters available for this command. See [Accessing Command Line Interface Help](#) on page 53.

For set up information regarding CLIs on your Roving Edge Infrastructure device, see [Using the Command Line Interface](#).

Using the API

Run the [DeleteBucket](#) operation to delete an object storage bucket on your Roving Edge Infrastructure devices.

Objects for Roving Edge Infrastructure

Describes how to manage the object storage object tasks, including creating, updating, and deleting objects, on your Roving Edge Infrastructure.

Stored objects can be as small as 0 bytes or as large as 10 TiB.

You can perform the following object management tasks:

- [Listing Objects](#)
- [Getting an Object's Details](#)
- [Uploading an Object](#)
- [Downloading an Object](#)
- [Deleting an Object](#)
- [Bulk Object Management](#)
- [Multipart Upload Tasks](#)

See [Managing Objects](#) in the Oracle Cloud Infrastructure documentation for more information on this feature.

Listing Objects

Describes how to list the objects contained within an Object Storage bucket on your Roving Edge Infrastructure devices.

Using the Device Console

1. Open the navigation menu and select **Storage > Object Storage & Archive Storage**. The **Buckets** page appears. All buckets are listed in tabular form.
2. Click the bucket whose details you want to get. The bucket's **Details** page appears. All objects are listed in tabular form.
3. Enable **Show Deleted Objects** to display those objects that were versioned, but subsequently deleted. If an object listed has versioning applied to it, you can click the Down arrow at the right side of the object's entry to display the versions.

Using the CLI

Use the `oci os object list` command and required parameters how to list the objects contained within an Object Storage bucket on your Roving Edge Infrastructure devices:

```
oci os object list --bucket-name bucket_name [OPTIONS]
```

For example:

```
oci os object list --bucket-name os_test
{
  "data": [
    {
      "archival-state": null,
      "etag": "6e3fc5a09c1f4912946fee5f8251a99",
      "md5": "bj/FoJzx9JEpRv71+CUamQ==",
      "name": "file1.txt",
      "size": 2211,
      "storage-tier": null,
      "time-created": "2023-06-02T12:38:25.243000+00:00",
      "time-modified": "2023-06-02T12:38:25.243000+00:00"
    },
    {
      "archival-state": null,
      "etag": "6e3fc5a09c1f4912946fee5f8251a99",
      "md5": "bj/FoJzx9JEpRv71+CUamQ==",
      "name": "file_with_new_name.txt",
      "size": 2211,
      "storage-tier": null,
      "time-created": "2023-06-02T12:36:39.721000+00:00",
```

```

    "time-modified": "2023-06-02T12:36:39.721000+00:00"
  }
],
"prefixes": []
}

```

Refer to your Roving Edge Infrastructure device's CLI help for a list of parameters available for this command. See [Accessing Command Line Interface Help](#) on page 53.

For set up information regarding CLIs on your Roving Edge Infrastructure device, see [Using the Command Line Interface](#).

Using the API

Run the [ListObjects](#) operation to list the objects contained within an Object Storage bucket on your Roving Edge Infrastructure devices.

Getting an Object's Details

Describes how to get the details of an object contained within an Object Storage bucket on your Roving Edge Infrastructure devices.

Using the Device Console

1. Open the navigation menu and select **Storage > Object Storage & Archive Storage**. The **Buckets** page appears. All buckets are listed in tabular form.
2. Click the bucket whose details you want to get. The bucket's **Details** page appears. All objects are listed in tabular form.
3. Select the Actions menu (⋮) for the object whose details you want to get and click **View Object Details**. The object's **Details** page appears. If object has versioning applied to it, the command is renamed View Object Versioning Details. The **ObjecAll** versions of the object are

Using the CLI

Use the [oci os object head](#) command and required parameters to get the details of an object contained within an Object Storage bucket on your Roving Edge Infrastructure devices:

```
oci os object head --bucket-name bucket_name --name name [OPTIONS]
```

For example:

```
oci os object head --bucket-name my_bucket --name file1.txt
{
  "content-length": "2211",
  "content-md5": "bj/FoJzx9JEpRv7l+CUamQ==",
  "content-type": "application/octet-stream",
  "date": "Fri, 02 Jun 2023 12:37:09 GMT",
  "etag": "6e3fc5a09cf1f4912946fee5f8251a99",
  "last-modified": "Fri Jun 02 12:36:39 GMT 2023",
  "opc-client-request-id": "exampleuniqueID",
  "opc-request-id": "exampleuniqueID"
}
```

Refer to your Roving Edge Infrastructure device's CLI help for a list of parameters available for this command. See [Accessing Command Line Interface Help](#) on page 53.

For set up information regarding CLIs on your Roving Edge Infrastructure device, see [Using the Command Line Interface](#).

Using the API

Run the [HeadObject](#) operation to get the details of an object contained within an Object Storage bucket on your Roving Edge Infrastructure devices.

Uploading an Object to an Object Storage Bucket on a Device

Learn how to upload an object to an Object Storage bucket on your Roving Edge Infrastructure device.

To upload objects in bulk using the CLI, see [Bulk Object Management](#).

Note:

A Device Console session expires after 4 hours. If you use the Device Console to upload a large object, and the upload duration exceeds the session window, the upload fails. For large objects, use the CLI to perform multipart uploads to the device Object Storage bucket.

Using the Device Console

The Device Console uses multipart uploads to upload objects larger than 64 MiB.

1. Open the navigation menu and select **Storage > Object Storage & Archive Storage**. The **Buckets** page appears. All buckets are listed in tabular form.
2. Click the bucket to which you want to upload objects. The bucket's **Details** page appears. All objects are listed in tabular form.
3. Click **Upload**. The **Upload Objects** dialog box appears.

Note:

Checking objects in the **Objects** list and then clicking **Upload** does not automatically upload those files. Select files you want to upload in the **Upload Objects** dialog box.

4. Specify an **Object Name Prefix** value. This prefix value is prepended to each one of the files you upload. You can specify the following prefix strings:
 - Prefix strings without a delimiter for matching purposes to perform allowed bulk operations
5. Select the group of objects you want to upload using any combination of the following methods:
 - Drag and drop one or more files from your computer.
 - Click the **select files** link and select the files you want to upload.

The files you select to upload are displayed in a list. If you decide that you do not want to upload a particular file, click the **X** to the right of the file name.

If the files you select to upload are already stored in the bucket or folder with the same name, the Console displays messages warning you of an overwrite.

6. Click **Upload**. The selected objects are uploaded and displayed in the list of objects in the bucket.
7. Click **Close** to return to the bucket's **Details** page.

Using the CLI

Use the `oci os object put` command and required parameters to upload an Object Storage object to a bucket on your Roving Edge Infrastructure devices:

```
oci os object put --bucket-name bucket_name --file file_name [OPTIONS]
```

Example:

```
oci os object put --bucket-name my_bucket --file file1.txt --name
file_with_new_name.txt
Uploading object [#####] 100%
{
  "etag": "6e3fc5a09cflf4912946fee5f8251a99",
  "opc-content-md5": "bj/FoJzx9JEpRv71+CUamQ=="
}
```

Multipart Uploads

Use the `oci os object put` command with the following parameters to perform a multipart upload:

- `part-size` *part_size*
Specify the *part_size* in MiB to use when the file is split into multiple parts and then combined. Part size must be greater than 10 MiB and defaults to 128 MiB.
- `--parallel-upload-count` *number_of_parallel_operations*
Specify the *number_of_parallel_operations* as an integer range for the number of parallel operations to perform. Decreasing this value makes the process less resource intensive but it might take longer. Increasing this value might decrease the time taken, but the process consumes more system resources and network bandwidth. The maximum is 1000.

```
oci os object put --bucket-name bucket_name --file file_location --part-size part_size --parallel-upload-count <maximum_number_parallel_uploads> [OPTIONS]
```

Example:

```
oci os object put --bucket-name MyBucket --file ~/path/to/file --part-size 500 --parallel-upload-count 10
Upload ID: 12345678-1234-1234-5678-c374a8f33998
Split file into 12 parts for upload.
Uploading object ##### 100%
{ "etag": "861c8341-74d8-4142-8da4-28e1ce7783ba", "last-modified": "Wed, 24 Apr 2024 19:59:15 GMT", "opc-multipart-md5": "9Qnleyou2yMiy009Bc7o1A==12" }
```

Refer to your Roving Edge Infrastructure device's CLI help for a list of parameters available for this command. See [Accessing Command Line Interface Help](#) on page 53.

For set up information regarding CLIs on your Roving Edge Infrastructure device, see [Using the Command Line Interface](#).

Using the API

Run the `PutObject` operation to upload an Object Storage object to a bucket on your Roving Edge Infrastructure devices.

Downloading an Object

Learn how to download an Object Storage object from a Roving Edge Infrastructure device to your computer.

To download objects in bulk using the command line interface (CLI), see [Bulk Object Management](#)

Using the Device Console

1. Open the navigation menu and select **Storage > Object Storage & Archive Storage**. The **Buckets** page appears. All buckets are listed in tabular form.
2. Click the bucket whose details you want to get. The bucket's **Details** page appears. All objects are listed in tabular form.
3. Select the Actions menu (⋮) for the object whose details you want to get and click **View Object Details**. The **Object Details** dialog box appears.
4. Click **Download**.

Alternately, you can select the Actions menu (⋮) for the object in the Objects page and click **Download**.

The object is downloaded to your local computer in the default download location.

Using the CLI

Use the `oci os object get` command and required parameters to download an object contained to a bucket on your Roving Edge Infrastructure devices:

```
oci os object get --bucket-name bucket-name --file file --name name
[OPTIONS]
```

For example:

```
oci os object get --bucket-name my)bucket --name file1.txt --file
file_downloaded.txt
Downloading object [#####] 100%
```

Refer to your Roving Edge Infrastructure device's CLI help for a list of parameters available for this command. See [Accessing Command Line Interface Help](#) on page 53.

For set up information regarding CLIs on your Roving Edge Infrastructure device, see [Using the Command Line Interface](#).

Using the API

Run the `GetObject` operation to download an Object Storage object contained to a bucket on your Roving Edge Infrastructure devices.

Deleting an Object

Describes how to delete an object storage object contained within an object storage bucket on your Roving Edge Infrastructure devices.

To delete objects in bulk using the command line interface (CLI), see [Bulk Object Management](#)

Using the Device Console

1. Open the navigation menu and select **Storage > Object Storage & Archive Storage**. The **Buckets** page appears. All buckets are listed in tabular form.
2. Click the bucket containing the object you want to delete. The bucket's **Details** page appears. All objects are listed in tabular form.
3. Check each object that you want to delete.
4. Click **Delete Objects**. To delete a single object, select the Actions menu (⋮) for that object in the Buckets page and click **Delete**.
5. Confirm the deletion when prompted.

Using the CLI

Use the following command and required parameters to delete an object storage object contained within an object storage bucket on your Roving Edge Infrastructure devices:

```
oci os object delete --bucket-name bucket-name --name name [OPTIONS]
```

For example:

```
oci os object delete --bucket-name my_bucket --name file_with_new_name.txt
Are you sure you want to delete this resource? [y/N]: y
```

Refer to your Roving Edge Infrastructure device's CLI help for a list of parameters available for this command. See [Accessing Command Line Interface Help](#) on page 53.

For set up information regarding CLIs on your Roving Edge Infrastructure device, see [Using the Command Line Interface](#).

Using the API

Run the [DeleteObject](#) operation to delete an object storage object contained within an object storage bucket on your Roving Edge Infrastructure devices.

Bulk Object Management

Describes how to upload, download, and delete objects in bulk on your Roving Edge Infrastructure devices.

Bulk Uploading Objects Using the CLI

Use the [oci os object bulk-upload](#) command and required parameters to upload objects in bulk on a Roving Edge Infrastructure device:

```
oci os object bulk-upload --bucket-name bucket_name --src-dir src_dir [OPTIONS]
```

where *src_dir* is the source directory on your devices.

For example:

```
oci os object bulk-upload --bucket-name my_bucket --src-dir test_directory
Uploaded file1.txt [#####] 100%
Uploaded file2.txt [#####] 100%

{
  "skipped-objects": [],
  "upload-failures": {},
  "uploaded-objects": {
    "file1.txt": {
      "etag": "6e3fc5a09c1f4912946fee5f8251a99",
      "opc-content-md5": "bj/FoJzx9JEpRv7l+CUamQ=="
    },
    "file2.txt": {
      "etag": "9f69ca10c97395570d0f9734e7f95e87",
      "opc-content-md5": "n2nKEM1z1VcND5c05/lehw=="
    }
  }
}
```

Refer to your Roving Edge Infrastructure device's CLI help for a list of parameters available for this command. See [Accessing Command Line Interface Help](#) on page 53.

For set up information regarding CLIs on your Roving Edge Infrastructure device, see [Using the Command Line Interface](#).

Bulk Downloading Objects using the CLI

Use the [oci os object bulk-download](#) command and required parameters to download objects in bulk on a Roving Edge Infrastructure device:

```
oci os object bulk-download --bucket-name bucket-name --download-dir download-dir [OPTIONS]
```

For example:

```
oci os object bulk-download --bucket-name my_bucket --download-dir
test_directory_download
Downloaded file1.txt [#####] 100%
Downloaded file2.txt [#####] 100%
{
  "download-failures": {},
  "downloaded-objects": [
    "file1.txt",
```

```

    "file2.txt"
  ],
  "skipped-objects": []
}

```

Refer to your Roving Edge Infrastructure device's CLI help for a list of parameters available for this command. See [Accessing Command Line Interface Help](#) on page 53.

For set up information regarding CLIs on your Roving Edge Infrastructure device, see [Using the Command Line Interface](#).

Bulk Deleting Objects using the CLI

Enter the `oci os object bulk-delete` command and required parameters to delete objects in bulk on a Roving Edge Infrastructure device:

```
oci os object bulk-delete --bucket-name bucket_name [OPTIONS]
```

For example:

```

oci os object bulk-delete --bucket-name my_bucket
WARNING: This command will delete at least 2 objects. Are you sure you wish
to continue? [y/N]: y
Deleted object file1.txt [#####] 100%
Deleted object file2.txt [#####] 100%
{
  "delete-failures": {},
  "deleted-objects": [
    "file1.txt",
    "file2.txt"
  ]
}

```

Refer to your Roving Edge Infrastructure device's CLI help for a list of parameters available for this command. See [Accessing Command Line Interface Help](#) on page 53.

For set up information regarding CLIs on your Roving Edge Infrastructure device, see [Using the Command Line Interface](#).

Bulk Deleting Object Versions using the CLI

Enter the `oci os object bulk-delete-versions` command and required parameters to delete all object versions in bulk on a Roving Edge Infrastructure device:

```
oci os object bulk-delete-versions --bucket-name bucket_name [OPTIONS]
```

For example:

```

oci os object bulk-delete-versions --bucket-name my_bucket "
{
  "delete-failures": {},
  "deleted-objects": [
    "20MB.bin,SgXGrKMkxsNFm8.nhr4fFGU3qz4M7VY",
    "20MB.bin,pajzkAEvTJJQWE78Bog3nSnOtRdjBLS"
  ]
}

```

Refer to your Roving Edge Infrastructure device's CLI help for a list of parameters available for this command. See [Accessing Command Line Interface Help](#) on page 53.

For set up information regarding CLIs on your Roving Edge Infrastructure device, see [Using the Command Line Interface](#).

Multipart Upload Tasks

Describes how to perform multipart upload tasks that move large Object Storage objects to a bucket on your Roving Edge Infrastructure devices.

You can perform the following multipart upload tasks:

- [Listing Multipart Uploads](#)
- [Aborting Multipart Uploads](#)

See [Using Multipart Uploads](#) in the Oracle Cloud Infrastructure documentation for more information on this feature.

Listing Multipart Uploads for Roving Edge Infrastructure

Describes how to list the multipart uploads that move large objects to an Object Storage bucket on your Roving Edge Infrastructure devices.

Using the Device Console

This task cannot be performed using the Device Console.

Using the CLI

Use the `oci os multipart list` command and required parameters to list the multipart uploads that move large objects to an Object Storage bucket on your Roving Edge Infrastructure devices:

```
oci os multipart list --bucket-name bucket_name [OPTIONS]
```

For example:

```
oci os multipart list --bucket-name my_bucket
{
  "data": [
    {
      "bucket": "my_bucket",
      "namespace": "rover-namespace",
      "object": "50MB.bin",
      "storage-tier": null,
      "time-created": "2023-06-02T12:56:30.270000+00:00",
      "upload-id": "2~JiwKkKpDd1EMZVoarZ6ZihtQEDcULtH"
    }
  ]
}
```

Refer to your Roving Edge Infrastructure device's CLI help for a list of parameters available for this command. See [Accessing Command Line Interface Help](#) on page 53.

For set up information regarding CLIs on your Roving Edge Infrastructure device, see [Using the Command Line Interface](#).

Using the API

Run the [ListMultipartUploads](#) operation to list the multipart uploads that move large objects to an Object Storage bucket on your Roving Edge Infrastructure devices.

Aborting Multipart Uploads

Describes how to abort multipart uploads to an Object Storage bucket on your Roving Edge Infrastructure devices.

Using the Device Console

This task can't be performed using the Device Console.

Using the CLI

Use the `oci os multipart abort` command and required parameters to abort multipart uploads to an Object Storage bucket on your Roving Edge Infrastructure devices:

```
oci os multipart abort --bucket-name bucket_name --object-name object_name
--upload-id upload_ocid [OPTIONS]
```

For example:

```
oci os multipart abort --bucket-name my_bucket --object-name 50MB.bin --
upload-id 2~JiwKkKpDd1EMZVoarZ6ZihtQEDcULtH
{
  "data": [
    {
      "etag": "5f363e0e58a95f06cbe9bbc662c5dfb6",
      "md5": "5f363e0e58a95f06cbe9bbc662c5dfb6",
      "part-number": 3,
      "size": 5242880
    }
  ],
  "opc-next-page": "3"
}
WARNING: Are you sure you want to permanently remove this incomplete upload?
[y/N]: y
```

Refer to your Roving Edge Infrastructure device's CLI help for a list of parameters available for this command. See [Accessing Command Line Interface Help](#) on page 53.

For set up information regarding CLIs on your Roving Edge Infrastructure device, see [Using the Command Line Interface](#).

Using the API

Run the [AbortMultipartUpload](#) operation to abort multipart uploads to an Object Storage bucket on your Roving Edge Infrastructure devices.

Running Functions on Object Storage for Roving Edge Infrastructure

Describes how to assign a function to an object storage event for Roving Edge Infrastructure.

You can assign a function to an object storage event. For example, you can configure the function to update any bucket object, including the object that triggered the event. When triggered, the Events service attempts to call the function indefinitely until it succeeds. You can see pending events and the calls statistics in the Device Console. You can cancel any pending event.

1. Launch the `orei-function-server-image-vi.oci` functions platform image as a virtual machine compute instance. See [Instances for Roving Edge Infrastructure Devices](#) on page 189 for more information.
2. Set up your functions within this instance.
3. Follow the steps to begin creating an event. See [Creating an Events Rule](#) for more information.
4. Provide a name and description for the function-based event.
5. Configure the following in the **Rule Conditions** section of the Create Rule dialog box:

Condition: Select **Event Type** from the list.

Service Name: Select **Object Storage** from the list.

Event Type: Select **Object - Create** from the list.

Rule Logic: Enter the function.

6. Click + **Another Condition** to add another function-based condition entry, or any other type of condition.
7. Complete the event rule creation.

Object Versioning for Roving Edge Infrastructure

Describes how to enable and manage the versioning of objects in an object storage bucket on your Roving Edge Infrastructure.

You can apply versioning to objects that you upload to your Roving Edge Infrastructure device's object store. The object versioning feature directs object storage to automatically create an object version each time a new object is uploaded, an existing object is overwritten, or when an object is deleted. Roving Edge Infrastructure supports the following object versioning states for objects:

- **Disabled:** When you upload an object with the same name as an existing object, the object is overwritten and the overwritten object is not retained or recoverable. When you delete an object, the deletion is permanent and objects are not recoverable.
- **Enabled:** When you upload an object with the same name as an existing object, the existing object becomes a previous version and the newly uploaded object becomes the latest version. Each uploaded object is assigned a unique version identifier. When you delete an object, object storage retains a version of the deleted object.

You enable object versioning when creating a bucket in your Roving Edge Infrastructure device's object storage. A bucket that has the versioning feature enabled can generate and contain many versions of an object. You can only enable versioning in a bucket at the time of its creation. You cannot enable or disable versioning in a bucket that already exists.

Note:

If you want to apply versioning to your uploaded objects, but none of your available buckets has versioning enabled, you cannot use them. Instead, you must create a new bucket with versioning enabled, and upload your objects to that bucket. See [Creating a Bucket](#).

You can perform the following object versioning tasks:

- [Enabling Object Versioning](#)
- [Listing Object Versions](#)
- [Getting an Object Version's Details](#)
- [Downloading an Objects Version](#)
- [Deleting an Objects Version](#)
- [Recovering a Deleted Object Version](#)

See [Using Object Versioning](#) in the Oracle Cloud Infrastructure documentation for more information on this feature.

Enabling Object Versioning for Roving Edge Infrastructure

Describes how to enable versioning of objects when creating an object storage bucket.

Using the Device Console

Follow the steps for creating a bucket using the Device Console as described in [Creating a Bucket](#). Select **Enable Object Versioning** to apply versioning to all objects that you upload.

Using the CLI

Run the `oci os bucket create` command to create a bucket using the CLI as described in [Creating a Bucket](#). Include the `--versioning enabled` parameter in the command. For example:

```
oci os bucket create ... --versioning enabled ...
```

Using the API

Run the `CreateBucket` operation to create a bucket using the API as described in [Creating a Bucket](#). Include the `versioning: enabled` attribute in the operation.

Listing an Object's Versions for Roving Edge Infrastructure

Describes how to list the versions of an object in an object storage bucket on your Roving Edge Infrastructure device.

Only those objects that were uploaded to an object storage bucket with versioning enabled will have their versions available for listing.

Using the Device Console

1. Open the navigation menu and select **Storage > Object Storage & Archive Storage**. The **Buckets** page appears. All buckets are listed in tabular form.
2. Click the bucket whose details you want to get. The bucket's **Details** page appears. All objects are listed in tabular form.
3. (optional) Enable **Show Deleted Objects** to display those objects that were versioned, but subsequently deleted.
4. Click the Down arrow at the right side of the object's entry to display the versions.

Each version of the object is displayed as a separate entry that you can perform various tasks on using the Actions menu (⋮).

Using the CLI

Use the `oci os object list-object-versions` command and required parameters to list the versions of an object in the Roving Edge Infrastructure device's object storage bucket:

```
oci os object list-object-versions --bucket-name bucket_name [OPTIONS]
```

Refer to your Roving Edge Infrastructure device's CLI help for a list of parameters available for this command. See [Accessing Command Line Interface Help](#) on page 53.

For set up information regarding CLIs on your Roving Edge Infrastructure device, see [Using the Command Line Interface](#).

Using the API

Run the `ListObjectVersions` operation to list the versions of an object in the Roving Edge Infrastructure device's object storage bucket.

Getting an Object Version's Details for Roving Edge Infrastructure

Describes how to get the details for a particular version of an object in an object storage bucket on your Roving Edge Infrastructure device.

Only those objects that were uploaded to an object storage bucket with versioning enabled will have their versions available for getting details.

Using the Device Console

1. Open the navigation menu and select **Object Storage > Object Storage**. The **Buckets** page appears. All buckets are listed in tabular form.
2. Click the bucket whose containing the object whose version details you want to get. The bucket's **Details** page appears. All objects are listed in tabular form.
3. (optional) Enable **Show Deleted Objects** to display those objects that were versioned, but subsequently deleted.
4. Click the Down arrow at the right side of the object's entry to display the versions.
5. Click the Actions menu (⋮) of the version whose details you want to get and click **View Object Details**.

The **Object Version Details** dialog box appears. It contains information on the object version including basic information on the version, response headers, and object contents.

Using the CLI

Run the `oci os object head` command to get details of an object's version from a bucket using the CLI as described in [Getting an Object's Details](#). Include the `--version-id` parameter in the command to specify the version being deleted. For example:

```
oci os object head ... --version-id version-id ...
```

Using the API

Run the `HeadObject` operation to get details of an object's version in the Roving Edge Infrastructure device's object storage bucket as described in [Getting an Object's Details](#). Include the `versionId` attribute to specify the object version being delete.

Downloading an Object Version for Roving Edge Infrastructure

Describes how to download a particular version of an object in an object storage bucket on your Roving Edge Infrastructure device.

Only those objects that were uploaded to an object storage bucket with versioning enabled will have their versions available for downloading.

Using the Device Console

1. Open the navigation menu and select **Object Storage > Object Storage**. The **Buckets** page appears. All buckets are listed in tabular form.
2. Click the bucket that contains the object whose version you want to download. The bucket's **Details** page appears. All objects are listed in tabular form.
3. (optional) Enable **Show Deleted Objects** to display those objects that were versioned, but subsequently deleted.
4. Click the Down arrow at the right side of the object's entry to display the versions.
5. Click the Actions menu (⋮) of the version you want to download and click **Download**.

The **Download Object** dialog box appears displaying the progress of the object being downloaded. You can also cancel the download by clicking **Cancel Download**.

Using the CLI

Run the `oci os object get` command to download an object from a bucket using the CLI as described in [Downloading an Object](#). Include the `--version-id` parameter in the command to specify the version being downloaded. For example:

```
oci os object get ... --version-id version-id ...
```

Using the API

Run the `GetObject` operation to delete the version of an object in the Roving Edge Infrastructure device's object storage bucket as described in [Downloading an Object](#). Include the `versionId` attribute to specify the object version being delete.

Deleting an Object Version for Roving Edge Infrastructure

Describes how to delete a particular version of an object in an object storage bucket on your Roving Edge Infrastructure device.

Only those objects that were uploaded to an object storage bucket with versioning enabled will have their versions available for deleting.

To delete object versions in bulk using the command line interface (CLI), see [Bulk Object Management](#)

Using the Device Console

1. Open the navigation menu and select **Object Storage > Object Storage**. The **Buckets** page appears. All buckets are listed in tabular form.
2. Click the bucket containing the object whose version you want to delete. The bucket's **Details** page appears. All objects are listed in tabular form.
3. (optional) Enable **Show Deleted Objects** to display those objects that were versioned, but subsequently deleted.
4. Click the Down arrow at the right side of the object's entry to display the versions.
5. Click the Actions menu (⋮) of the version you want to delete and click **Delete**.
6. Confirm the deletion.

The list of versions of the object no longer includes the version you deleted.

Using the CLI

Run the `oci os object delete` command to delete an object from a bucket using the CLI as described in [Deleting an Object](#). Include the `--version-id` parameter in the command to specify the version being deleted. For example:

```
oci os object delete ... --version-id version-id ...
```

Using the API

Run the `DeleteObject` operation to delete the version of an object in the Roving Edge Infrastructure device's object storage bucket as described in [Deleting an Object](#). Include the `versionId` attribute to specify the object version being delete.

Recovering a Deleted Object Version

Describes how to recover a deleted object version contained within an object storage bucket on your Roving Edge Infrastructure devices.

Recovering a deleted object version requires removing the delete marker that was created when you deleted the latest version of an object. The previous version of the object listed just below the delete marker is recovered and becomes the latest version of the object.

Using the Device Console

1. Open the navigation menu and select **Object Storage > Object Storage**. The **Buckets** page appears. All buckets are listed in tabular form.
2. Click the bucket containing the object whose deleted version you want to recover. The bucket's **Details** page appears. All objects are listed in tabular form.
3. Enable **Show Deleted Objects** to display those objects that were versioned, but subsequently deleted.
4. Click the Down arrow at the right side of the object's entry to display the versions that you can recover. Look for the entry that includes "(Delete Marker)" under the **Last Modified** column.
5. Click the Actions menu (⋮) of the entry with the Delete Marker identifier and click **Delete**.
6. Confirm the deletion.

The previous version of the object listed just below the delete marker is recovered and becomes the latest version of the object.

Block Volumes

Describes how to manage block volume tasks, including creating, updating, and deleting block volumes, on your Roving Edge Infrastructure devices.

You can perform the following block volume tasks:

- [Creating a Block Volume](#)
- [Listing Block Volumes](#)
- [Getting a Block Volume's Details](#)
- [Renaming a Block Volume](#)
- [Deleting a Block Volume](#)
- [Block Volume Attachment Management](#)

The Block Volume service doesn't reserve storage space for block volumes and boot volumes in advance. Instead, storage space is consumed when the data is written to the block volume. For example, if a 100 GB block volume is created, it doesn't mean that 100 GB is reserved from the total available storage space for this block volume. The storage space remains available to all services and can be exhausted before the 100 GB volume is filled with data.

Also, the Block Volume service doesn't validate the specified size of a created block volume against the available storage space. This lack of validation can lead to over subscription when the total size of created volumes exceeds the storage space available on the device. Don't rely on block volume sizes to calculate storage space usage.

Important:

Plan the total storage needs of your Compute (boot volumes), Block Storage, and Object Storage resources in advance to ensure your storage doesn't exceed 80% of the total available storage. Then regularly monitor the available storage space to avoid oversubscription problems. If your storage capacities reach 80% or higher, see [Avoiding Storage Overages Using Safe Mode](#) on page 38.

See [Overview of Block Volume](#) in the Oracle Cloud Infrastructure documentation for more information on this service.

Creating a Block Volume for a Roving Edge Infrastructure Device

Describes how to create a block volume on your Roving Edge Infrastructure device.

Volumes can be created in sizes ranging from 50 GB (51200 MB) to 6 TB (6291456 MB), in 1 GB (1024 MB) increments. By default, volumes are 300 GB (307200 MB).

See [Creating a Volume](#) in the Oracle Cloud Infrastructure documentation for more information on this feature.

Using the Device Console

1. Open the navigation menu and select **Block Storage > Block Volumes**. The **Block Volumes** page appears. All block volumes are listed in tabular form.
2. Select a **State** from the list to limit the block volumes displayed to that state.
3. Click **Create Block Volume**. The **Create Block Volume** dialog box appears.
4. Complete the following:
 - **Name:** A user-friendly name or description.
 - **Size:** Must be between **50 GB** and **6 TB**. You can choose in 1 GB increments within this range. The default is 300 GB. If you choose a size outside of your service limit, you might be prompted to request an increase.
5. Check **View detail page after this block volume is created** to display the block volume's **Details** page after you create it.
6. Click **Create Block Volume**. The volume is ready to attach after its icon no longer lists it as **Provisioning** in the **Volume** list.

Using the CLI

Use the `oci bv volume create` command and required parameters to create a block volume on your Roving Edge Infrastructure devices:

```
oci bv volume create [OPTIONS]
```

Refer to your Roving Edge Infrastructure device's CLI help for a list of parameters available for this command. See [Accessing Command Line Interface Help](#) on page 53.

For set up information regarding CLIs on your Roving Edge Infrastructure device, see [Using the Command Line Interface](#).

Using the API

Run the [CreateVolume](#) operation to create a block volume on your Roving Edge Infrastructure devices.

Listing Block Volumes for a Roving Edge Infrastructure Device

Describes how to list the blocks volume on your Roving Edge Infrastructure device.

See [Listing Volumes](#) in the Oracle Cloud Infrastructure documentation for more information on this feature.

Using the Device Console

1. Open the navigation menu and select **Block Storage > Block Volumes**. The **Block Volumes** page appears. All block volumes are listed in tabular form.
2. Select a **State** from the list to limit the block volumes displayed to that state.

Using the CLI

Use the [oci bv volume list](#) command and required parameters to list the blocks volume on your Roving Edge Infrastructure devices:

```
oci bv volume list --compartment-id compartment_ocid [OPTIONS]
```

To determine your Roving Edge Infrastructure device compartment OCID, see [Compartments](#).

Refer to your Roving Edge Infrastructure device's CLI help for a list of parameters available for this command. See [Accessing Command Line Interface Help](#) on page 53.

For set up information regarding CLIs on your Roving Edge Infrastructure device, see [Using the Command Line Interface](#).

Using the API

Run the [ListVolumes](#) operation to list the blocks volume on your Roving Edge Infrastructure devices.

Getting a Block Volume's Details

Describes how to get the details of a block volume on your Roving Edge Infrastructure device.

See [Listing Volumes](#) in the Oracle Cloud Infrastructure documentation for more information on this feature.

Using the Device Console

1. Open the navigation menu and select **Block Storage > Block Volumes**. The **Block Volumes** page appears. All block volumes are listed in tabular form.
2. Select a **State** from the list to limit the block volumes displayed to that state. Click the block volume whose details you want to get. The block volume's **Details** page appears.

Using the CLI

Use the [oci bv volume get](#) command and required parameters to get the details of a block volume on your Roving Edge Infrastructure devices:

```
oci bv volume get --volume-id volume_ocid [OPTIONS]
```

Refer to your Roving Edge Infrastructure device's CLI help for a list of parameters available for this command. See [Accessing Command Line Interface Help](#) on page 53.

For set up information regarding CLIs on your Roving Edge Infrastructure device, see [Using the Command Line Interface](#).

Using the API

Run the [GetVolume](#) operation to get the details of a block volume on your Roving Edge Infrastructure devices.

Renaming a Block Volume

Describes how to rename a block volume on your Roving Edge Infrastructure device.

1. Open the navigation menu and select **Block Storage > Block Volumes**. The **Block Volumes** page appears. All block volumes are listed in tabular form.
2. Select a **State** from the list to limit the block volumes displayed to that state.
3. Click the block volume you want to rename. The **Edit Block Volume** dialog box appears.
4. Enter the block volume's new name in the **Name** box.
5. Click **Save Changes**.

See [Renaming a Volume](#) in the Oracle Cloud Infrastructure documentation for more information on this feature.

Deleting a Block Volume

Describes how to delete a block volume from your Roving Edge Infrastructure device.

The volume cannot have an active connection to an instance. See [Deleting a Volume](#) in the Oracle Cloud Infrastructure documentation for more information on this feature.

Caution:

All data on the volume is permanently lost when the volume is deleted.

Using the Device Console

1. Open the navigation menu and select **Block Storage > Block Volumes**. The **Block Volumes** page appears. All block volumes are listed in tabular form.
2. Select a **State** from the list to limit the block volumes displayed to that state.
3. Click the block volume that you want to delete. The block volume's **Details** page appears.
4. Click **Terminate**.
5. Confirm the deletion when prompted.

Using the CLI

Use the `oci bv volume delete` command and required parameters to delete a block volume from your Roving Edge Infrastructure devices:

```
oci bv volume delete --volume-id volume_ocid [OPTIONS]
```

Refer to your Roving Edge Infrastructure device's CLI help for a list of parameters available for this command. See [Accessing Command Line Interface Help](#) on page 53.

For set up information regarding CLIs on your Roving Edge Infrastructure device, see [Using the Command Line Interface](#).

Using the API

Run the [DeleteVolume](#) operation to delete a block volume from your Roving Edge Infrastructure devices.

Block Volume Attachment Management

Describes how to manage block volume attachment tasks, including attaching, detaching, and listing block volumes attachments, to a compute instance on your Roving Edge Infrastructure devices.

You can perform the following block volume attachment tasks:

- [Attaching a Block Volume](#)
- [Detaching a Block Volume](#)
- [Listing Block Volume Attachments](#)
- [Getting a Block Volume Attachment's Details](#)

See [Overview of Block Volume](#) in the Oracle Cloud Infrastructure documentation for more information on this feature.

Attaching a Block Volume to a Roving Edge Infrastructure Device

Describes how to attach a block volume to a compute instance on your Roving Edge Infrastructure device.

See [Attaching a Volume](#) in the Oracle Cloud Infrastructure documentation for more information on this feature.

Using the Device Console

1. Open the navigation menu and select **Compute > Instances**. The **Instances** page appears. All instances are listed in tabular form.
2. Select a **State** from the list to limit the instances displayed to that state.
3. Click the instance to which you want to attach a block volume under **Instances**.
4. Click **Attached Block Volumes** in the lower left corner. The **Attached Block Volumes** page appears. All attached block volumes are listed in tabular form.
5. Click **Attach Block Volume**. The **Attach Block Volume** dialog box appears. By default, the attached block volume type is **Paravirtualized**.
6. Choose the volume selection option:
 - **Select Volume**: Select the volume from the **Block Volume** list.
 - **Enter Volume OCID**: Enter the OCID into the **Block Volume OCID** box.
7. **Select a Device Path**: Choose one from the list of device paths. For example:

```
/dev/oracleoci/oraclevdb
```

8. Select the access type:
 - **Read/Write**
 - **Read/Write - Shareable**
 - **Read-only**
9. Click **Attach**.

The block volume appears in the **Attached Block Volume** page.

Using the CLI

Use the `oci compute volume-attachment attach` command and required parameters to attach a block volume to a compute instance on your Roving Edge Infrastructure devices:

```
oci compute volume-attachment attach --instance-id instance_ocid --type
paravirtualized --volume-id volume_ocid --device device [OPTIONS]
```

where *device* might be `/dev/oracleoci/oraclevdb`.

Refer to your Roving Edge Infrastructure device's CLI help for a list of parameters available for this command. See [Accessing Command Line Interface Help](#) on page 53.

For set up information regarding CLIs on your Roving Edge Infrastructure device, see [Using the Command Line Interface](#).

Using the API



Run the [AttachVolume](#) operation to attach a block volume to a compute instance on your Roving Edge Infrastructure devices.

Detaching a Block Volume from a Roving Edge Infrastructure Device

Describes how to detach a block volume from a compute instance on your Roving Edge Infrastructure device.

See [Detaching a Volume](#) in the Oracle Cloud Infrastructure documentation for more information on this feature.

Using the Device Console

1. Open the navigation menu and select **Compute > Instances**. The **Instances** page appears. All instances are listed in tabular form.
2. Select a **State** from the list to limit the instances displayed to that state.
3. Click the instance from which you want to detach the volume under **Instances**. The instance's **Details** page appears.
4. Click **Attached Block Volumes** in the lower left corner. All attached block volumes are listed in tabular form.
5.  Select the Actions menu () for the block volume you want to detach and click **Detach**.
6. Confirm the detachment when prompted.

Using the CLI

Use the `oci compute volume-attachment detach` command and required parameters to detach a block volume from a compute instance on your Roving Edge Infrastructure devices:

```
oci compute volume-attachment detach --volume-attachment-
id volume_attachment_ocid [OPTIONS]
```

Refer to your Roving Edge Infrastructure device's CLI help for a list of parameters available for this command. See [Accessing Command Line Interface Help](#) on page 53.

For set up information regarding CLIs on your Roving Edge Infrastructure device, see [Using the Command Line Interface](#).

Using the API

Run the [DetachVolume](#) operation to detach a block volume from a compute instance on your Roving Edge Infrastructure devices.

Listing Block Volume Attachments within a Roving Edge Infrastructure Device

Describes how to list the block volumes attached to a compute instance on your Roving Edge Infrastructure device.

See [Listing Volume Attachments](#) in the Oracle Cloud Infrastructure documentation for more information on this feature.

Using the Device Console

1. Open the navigation menu and select **Compute > Instances**. The **Instances** page appears. All instances are listed in tabular form.
2. Select a **State** from the list to limit the instances displayed to that state.
3. Click the instance to which you want to attach a block volume under **Instances**.
4. Click **Attached Block Volumes** in the lower left corner. All attached block volumes are listed in tabular form.

Using the CLI

Use the `oci compute volume-attachment list` command and required parameters to list the block volumes attached to a compute instance on your Roving Edge Infrastructure devices:

```
oci compute volume-attachment list --volume-attachment-
id volume_attachment_ocid [OPTIONS]
```

Refer to your Roving Edge Infrastructure device's CLI help for a list of parameters available for this command. See [Accessing Command Line Interface Help](#) on page 53.

For set up information regarding CLIs on your Roving Edge Infrastructure device, see [Using the Command Line Interface](#).

Using the API

Run the [ListVolumeAttachments](#) operation to list the block volumes attached to a compute instance on your Roving Edge Infrastructure devices.

Getting a Block Volume Attachment's Details within a Roving Edge Infrastructure Device

Describes how to get the details of a block volume attached to a compute instance on your Roving Edge Infrastructure device.

See [Listing Volume Attachments](#) in the Oracle Cloud Infrastructure documentation for more information on this feature.

Using the Device Console

1. Open the navigation menu and select **Compute > Instances**. The **Instances** page appears. All instances are listed in tabular form.
2. (optional) Select a **State** from the list to limit the instances displayed to that state.
3. Click the instance to which you want to attach a block volume.
4. Click **Attached Block Volumes** in the lower left corner. All attached block volumes are listed in tabular form.
5. Click the block volume whose details you want to get. The block volume's **Details** page appears.

Using the CLI

Use the `oci compute volume-attachment get` command and required parameters to get the details of a block volume attached to a compute instance on your Roving Edge Infrastructure devices:

```
oci compute volume-attachment get --volume-attachment-  
id volume_attachment_ocid [OPTIONS]
```

Refer to your Roving Edge Infrastructure device's CLI help for a list of parameters available for this command. See [Accessing Command Line Interface Help](#) on page 53.

For set up information regarding CLIs on your Roving Edge Infrastructure device, see [Using the Command Line Interface](#).

Using the API

Run the [GetVolumeAttachment](#) operation to get the details of a block volume attached to a compute instance on your Roving Edge Infrastructure devices.

Networking for Roving Edge Infrastructure Devices

Describes how to manage your Networking resources on Oracle Cloud Infrastructure devices.

This section describes the following Roving Edge Infrastructure on-device services related to networking:

- [Virtual Cloud Networks \(VCNs\)](#)
- [Subnets](#)

Public IP Addresses

Describes how to manage public IPv4 addresses on instances in a virtual cloud network (VCN).

A public IP address is an IPv4 address that is reachable from the internet. If a resource in your tenancy needs to be directly reachable from the internet, it must have a public IP address. Depending on the type of resource, there might be other requirements.

Certain types of resources in your tenancy are designed to be directly reachable from the internet and therefore automatically come with a public IP address. For example: a NAT gateway or a public load balancer. Other types of resources are directly reachable only if you configure them to be. For example: instances in your VCN.

There are two types of public IPs:

- **Ephemeral:** Think of it as temporary and existing for the lifetime of the instance.
- **Reserved:** Think of it as persistent and existing beyond the lifetime of the instance it's assigned to. You can unassign it and then reassign it to another instance whenever you like. Exception: reserved public IPs on public load balancers.

You can perform the public IP address management tasks:

- [Creating a Reserved Public IP Address](#)
- [Listing Reserved Public IP Addresses](#)
- [Getting a Reserved Public IP Address' Details](#)
- [Editing a Reserved Public IP Address](#)
- [Deleting a Reserved Public IP Address](#)

See [Public IP Addresses](#) in the Oracle Cloud Infrastructure documentation for more information on this topic.

Ephemeral Public IP Addresses

The following sections address using ephemeral IP addresses:

Assigning an Ephemeral Public IP when Launching an Instance

When you launch an instance into a public subnet, there is an **Assign a Public IPv4 Address** check box on the **Create Compute Instance** dialog box. By default, the check box is selected, which means the instance gets an ephemeral public IP. If you do not want an ephemeral public IP assigned, perform one of the following:

- Deselect **Assign a Public IPv4 Address**.
- Delete the ephemeral public IP after instance launch.

Assigning an Ephemeral Public IP when Creating a Secondary VNIC

When you add a secondary VNIC to an instance, you choose whether the primary private IP on the new VNIC gets an ephemeral public IP. This choice is available only if the secondary VNIC is in a public subnet.

In the **Create VNIC** dialog box, there is an **Assign a public IPv4 address** check box. By default, the check box is not selected, which means the secondary VNIC does not get an ephemeral public IP. You must select the check box.

Assigning an Ephemeral Public IP to an Existing Private IP

The primary private IP must not have a reserved or ephemeral public IP already assigned to it. If it does, first delete the ephemeral public IP, or unassign the reserved public IP.

1. Open the navigation menu and click **Compute**. Click **Instances** under **Compute**. The instances are listed in tabular form.
2. Click the instance with the attached VNIC you need. The instance's **Details** page appears.
3. Click **Attached VNICs** under **Resources**. The primary VNIC and any secondary VNICs attached to the instance are listed in tabular form.
4. Click the VNIC with the IP address that you need. The VNIC's **Details** page appears.
5. Click **IP Addresses** under **Resources**. The VNIC's primary private IP and any secondary private IPs are listed in tabular form.

6. Click the Actions menu (⋮) for the VNIC's primary private IP, then select **Edit**. The **Edit Private IP Address** dialog box appears.
7. Select the **Ephemeral Public IP** option under **Public IP Type**. The **Ephemeral Public IP Address** box appears.
8. (optional) Enter a name for the public IP.
9. Click **Update**.

Deleting an Ephemeral Public IP from an Instance

1. Open the navigation menu and click **Compute**. Click **Instances** under **Compute**. The instances are listed in tabular form.
2. Click the instance with the attached VNIC you need. The instance's **Details** page appears.
3. Click **Attached VNICs** under **Resources**. The primary VNIC and any secondary VNICs attached to the instance are listed in tabular form.
4. Click the VNIC with the IP address that you need. The VNIC's **Details** page appears.
5. Click **IP Addresses** under **Resources**. The VNIC's primary private IP and any secondary private IPs are listed in tabular form.
6. Click the Actions menu (⋮) for the VNIC's primary private IP, then select **Edit**. The **Edit Private IP Address** dialog box appears.
7. Select the **No Public IP** option under **Public IP Type**.
8. Click **Update**.

Renaming an Ephemeral Public IP

1. Open the navigation menu and click **Compute**. Click **Instances** under **Compute**. The instances are listed in tabular form.
2. Click the instance with the attached VNIC you need. The instance's **Details** page appears.
3. Click **Attached VNICs** under **Resources**. The primary VNIC and any secondary VNICs attached to the instance are listed in tabular form.
4. Click the VNIC with the IP address that you need. The VNIC's **Details** page appears.
5. Click **IP Addresses** under **Resources**. The VNIC's primary private IP and any secondary private IPs are listed in tabular form.
6. Click the Actions menu (⋮) for the VNIC's primary private IP, then select **Edit**. The **Edit Private IP Address** dialog box appears.
7. Update the ephemeral public IP's name in the **Ephemeral Public IP Address** box.
8. Click **Update**.

Creating a Reserved Public IP Address for a Roving Edge Infrastructure Device

Describes how to create a reserved public IP address for your Roving Edge Infrastructure device.

Using the Device Console

1. Open the navigation menu and select **Networking > IP Management**. The **IP Management** page appears.
2. Click **Reserved Public IPs**. The **Reserved Public IP Addresses** page appears. The reserved public IP addresses are listed in tabular form.
3. Click **Create Reserved Public IP**. The **Create Reserved Public IP** dialog box appears.
4. Complete the following:
 - **Reserved Public IP Address Name**: Enter a name for the reserved public IP address.
 - **Create in Compartment**: Accept the default value.
 - **IP Address Source in <Compartment>**: (optional) The IP pool the reserved public IP is drawn from. If you do not select a pool you've created, the default Oracle pool is used.
5. Click **Reserved Public IP**.

The reserved public IP address you created appears in the list of reserved public IP addresses.

Using the CLI

Use the `oci network public-ip create` command and required parameters to create a reserved public IP address for your Roving Edge Infrastructure device:

```
oci network public-ip create --compartment-id compartment_ocid --lifetime
[EPHEMERAL|RESERVED] [OPTIONS]
```

where the possible values for `lifetime` are:

- **EPHEMERAL:** You must also specify a `privateIpId` with the **OCID** of the primary private IP you want to assign the public IP to. The public IP is created in the same availability domain as the private IP. An ephemeral public IP must always be assigned to a private IP, and only to the *primary* private IP on a VNIC, not a secondary private IP. Exception: If you create a NatGateway, Oracle automatically assigns the NAT gateway a regional ephemeral public IP that you cannot remove.
- **RESERVED:** You may also optionally assign the public IP to a private IP by specifying `privateIpId`. Or you can later assign the public IP with `UpdatePublicIp`.

To determine your Roving Edge Infrastructure device compartment OCID, see [Compartments](#).

Refer to your Roving Edge Infrastructure device's CLI help for a list of parameters available for this command. See [Accessing Command Line Interface Help](#) on page 53.

For set up information regarding CLIs on your Roving Edge Infrastructure device, see [Using the Command Line Interface](#).

Using the API

Run the `CreatePublicIp` operation to create a reserved public IP address for your Roving Edge Infrastructure device.

Listing Reserved Public IP Addresses for a Roving Edge Infrastructure Device

Describes how to list the reserved public IP addresses for your Roving Edge Infrastructure device.

Using the Device Console

1. Open the navigation menu and select **Networking > IP Management**. The **IP Management** page appears.
2. Click **Reserved Public IPs**.

The **Reserved Public IP Addresses** page appears. The reserved public IP addresses are listed in tabular form.

Using the CLI

Use the `oci network public-ip list` and required parameters to list the reserved public IP addresses for your Roving Edge Infrastructure device:

```
oci network public-ip list --compartment-id compartment_ocid --scope
[AVAILABILITY_DOMAIN|REGION] [OPTIONS]
```

where the possible values for `scope` are:

- **REGION:** The public IP exists within a region and is assigned to a regional entity (such as a NatGateway), or can be assigned to a private IP in any availability domain in the region. Reserved public IPs have `scope = REGION`, as do ephemeral public IPs assigned to a regional entity.
- **AVAILABILITY_DOMAIN:** The public IP exists within the availability domain of the entity it's assigned to, which is specified by the `availabilityDomain` property of the public IP object. Ephemeral public IPs that are assigned to private IPs have `scope = AVAILABILITY_DOMAIN`.

To determine your Roving Edge Infrastructure device compartment OCID, see [Compartments](#).

Refer to your Roving Edge Infrastructure device's CLI help for a list of parameters available for this command. See [Accessing Command Line Interface Help](#) on page 53.

For set up information regarding CLIs on your Roving Edge Infrastructure device, see [Using the Command Line Interface](#).

Using the API

Run the [ListPublicIps](#) operation to list the reserved public IP addresses for your Roving Edge Infrastructure device.

Getting a Reserved Public IP Address' Details for a Roving Edge Infrastructure Device

Describes how to get the details of a reserved public IP address for your Roving Edge Infrastructure device.

Using the Device Console

1. Open the navigation menu and select **Networking > IP Management**. The **IP Management** page appears.
2. Click **Reserved Public IPs**. The **Reserved Public IP Addresses** page appears. The reserved public IP addresses are listed in tabular form.

The reserved public IP addresses list contains the details on each address, including the state, IP address, VNIC, and IP pool.

Using the CLI

Use the `oci network public-ip get` command and required parameters to get the details of a reserved public IP address for your Roving Edge Infrastructure device:

```
oci network public-ip get [OPTIONS]
```

Refer to your Roving Edge Infrastructure device's CLI help for a list of parameters available for this command. See [Accessing Command Line Interface Help](#) on page 53.

For set up information regarding CLIs on your Roving Edge Infrastructure device, see [Using the Command Line Interface](#).

Using the API

Run the [GetPublicIp](#) operation to get the details of a reserved public IP address for your Roving Edge Infrastructure device.

Editing a Reserved Public IP Address for a Roving Edge Infrastructure Device

Describes how to edit a reserved public IP address for your Roving Edge Infrastructure device.

You can only rename the reserved public IP address using the Device Console. Use the CLI or API method to perform other edits on the IP address.

Using the Device Console

1. Open the navigation menu and select **Networking > IP Management**. The **IP Management** page appears.
2. Click **Reserved Public IPs**. The **Reserved Public IP Addresses** page appears. The reserved public IP addresses are listed in tabular form.
3. Click the Actions menu (⋮) to the right of the IP address, and select **Rename**. The **Rename** dialog box appears.
4. Enter the updated name the IP address and click **Save Changes**.

The reserved public IP address list reappears displaying the updated IP address name.

Using the CLI

Use the `oci network public-ip update` command and required parameters to edit a reserved public IP address for your Roving Edge Infrastructure device:

```
oci network public-ip update --public-ip-id public_ip_ocid [OPTIONS]
```

Refer to your Roving Edge Infrastructure device's CLI help for a list of parameters available for this command. See [Accessing Command Line Interface Help](#) on page 53.

For set up information regarding CLIs on your Roving Edge Infrastructure device, see [Using the Command Line Interface](#).



Using the API

Run the [UpdatePublicIp](#) operation to edit a reserved public IP address for your Roving Edge Infrastructure device.

Delete a Reserved Public IP Address for a Roving Edge Infrastructure Device

Describes how to delete a reserved public IP address from your Roving Edge Infrastructure device.

Using the Device Console

1. Open the navigation menu and select **Networking > IP Management**. The **IP Management** page appears.
2. Click **Reserved Public IPs**. The **Reserved Public IP Addresses** page appears. The reserved public IP addresses are listed in tabular form.
3.  Click the Actions menu () to the right of the IP address, and select **Terminate**.
4. Confirm the termination when prompted.

The reserved public IP address list reappears without the IP address you terminated.

Using the CLI

Use the `oci network public-ip delete` command and required parameters to delete a reserved public IP address from your Roving Edge Infrastructure device:

```
oci network public-ip delete --public-ip-id public_ip_ocid [OPTIONS]
```

Refer to your Roving Edge Infrastructure device's CLI help for a list of parameters available for this command. See [Accessing Command Line Interface Help](#) on page 53.

For set up information regarding CLIs on your Roving Edge Infrastructure device, see [Using the Command Line Interface](#).

Using the API

Run the [DeletePublicIp](#) operation to delete a reserved public IP address from your Roving Edge Infrastructure device.

Virtual Cloud Networks (VCNs) for Roving Edge Infrastructure Devices

Describes how to manage virtual cloud network (VCN) tasks, including creating, updating, and deleting VCNs, on your Roving Edge Infrastructure devices.

Only a single VCN is supported on each Roving Edge Infrastructure device.

You can perform the following virtual cloud network (VCN) tasks:

- [Creating a VCN](#)
- [Listing VCNs](#)
- [Getting a VCN's Details](#)
- [Editing a VCN](#)
- [Deleting a VCN](#)

See [Overview of VCNs and Subnets](#) in the Oracle Cloud Infrastructure documentation for more information on this feature.

Creating a VCN for a Roving Edge Infrastructure Device

Describes how to create a VCN on your Roving Edge Infrastructure device.

Only a single VCN is supported on each Roving Edge Infrastructure device.

These procedures create a VCN without any subnets or gateways for access. Manually create the subnets and other resources before using the VCN. Currently, Roving Edge Infrastructure supports only one VCN with only one CIDR Block.

Note:

The IPv6 option is not supported when creating a VCN. Including any reference to IPv6 in your creation of a VCN (`is-ipv6-enabled=true|false`) results in a failure.

Using the Device Console

1. Open the navigation menu and select **Networking > Virtual Cloud Networks**. The **Virtual Cloud Networks** page appears. The single virtual cloud network (VCN) is listed in tabular form.
2. Click **Create VCN**. The **Create a Virtual Cloud Network** dialog box appears.
3. Enter the following:
 - **Name:** A descriptive name for the VCN. It doesn't have to be unique, and it cannot be changed later in the Console (but you can change it with the API). Avoid entering confidential information.
 - **CIDR Block:** The one valid IPv4 CIDR block for the VCN. For example: 172.16.0.0/16. You cannot change this value later.
 - **DNS Resolution:** Check **Use DNS Hostnames in this VCN** if you want to enable this functionality. Checking this option is required for assignment of DNS hostnames to hosts in the VCN. Enabling this option is required if you plan to use the VCN's default DNS feature (called the *Internet and VCN Resolver*).

If enabled, you can specify a DNS label for the VCN, otherwise, the Device Console generates one for you. The dialog box automatically displays the corresponding **DNS Domain Name** for the VCN (<VCN DNS label>.oraclevcn.com).

4. Click **Create VCN**.

Next, create one or more subnets in the cloud network. See [Subnets for Roving Edge Infrastructure Devices](#) on page 257.

Using the CLI

Use the `oci network vcn create` command and required parameters to create a VCN on your Roving Edge Infrastructure devices.:

```
oci network vcn create --compartment-id compartment_ocid --cidr-block cidr_block [OPTIONS]
```

To determine your Roving Edge Infrastructure device compartment OCID, see [Compartments](#).

The `cidr_block` parameter lists the one valid IPv4 CIDR block for the VCN

For example: `--cidr-block 10.0.0.0/16`

Refer to your Roving Edge Infrastructure device's CLI help for a list of parameters available for this command. See [Accessing Command Line Interface Help](#) on page 53.

For set up information regarding CLIs on your Roving Edge Infrastructure device, see [Using the Command Line Interface](#).

Using the API

Run the `CreateVcn` operation to create a VCN on your Roving Edge Infrastructure devices..

Listing VCNs for a Roving Edge Infrastructure Device

Describes how to list the VCNs on your Roving Edge Infrastructure device.

Using the Device Console

1. Open the navigation menu and select **Networking > Virtual Cloud Networks**. The **Virtual Cloud Networks** page appears. The single virtual cloud network (VCN) is listed in tabular form.

Using the CLI

Use the `oci network vcn list` command and required parameters how to list the VCNs on your Roving Edge Infrastructure devices:

```
oci network vcn list --compartment-id compartment_ocid [OPTIONS]
```

To determine your Roving Edge Infrastructure device compartment OCID, see [Compartments](#).

Refer to your Roving Edge Infrastructure device's CLI help for a list of parameters available for this command. See [Accessing Command Line Interface Help](#) on page 53.

For set up information regarding CLIs on your Roving Edge Infrastructure device, see [Using the Command Line Interface](#).

Using the API

Run the `ListVcn` operation how to list the VCNs on your Roving Edge Infrastructure devices.

Getting a VCN's Details for a Roving Edge Infrastructure Device

Describes how to get the details of a VCN on your Roving Edge Infrastructure device.

Using the Device Console

1. Open the navigation menu and select **Networking > Virtual Cloud Networks**. The **Virtual Cloud Networks** page appears. The single virtual cloud network (VCN) is listed in tabular form.
2. Click the VCN. The VCN's **Details** page appears.

Using the CLI

Use the `oci network vcn get` command and required parameters to get the details of a VCN on your Roving Edge Infrastructure devices:

```
oci network vcn get --vcn-id vcn_ocid [OPTIONS]
```

Refer to your Roving Edge Infrastructure device's CLI help for a list of parameters available for this command. See [Accessing Command Line Interface Help](#) on page 53.

For set up information regarding CLIs on your Roving Edge Infrastructure device, see [Using the Command Line Interface](#).

Using the API

Run the `GetVcn` operation to get the details of a VCN on your Roving Edge Infrastructure devices.

Editing a VCN for a Roving Edge Infrastructure Device

Describes how to edit a VCN on your Roving Edge Infrastructure device.

Using the Device Console

This task can't be performed using the Device Console.

Using the CLI

Use the `oci network vcn update` command and required parameters to edit a VCN on your Roving Edge Infrastructure devices:

```
oci network vcn update --vcn-id vcn_ocid [OPTIONS]
```

Refer to your Roving Edge Infrastructure device's CLI help for a list of parameters available for this command. See [Accessing Command Line Interface Help](#) on page 53.

For set up information regarding CLIs on your Roving Edge Infrastructure device, see [Using the Command Line Interface](#).

Using the API

Run the [UpdateVcn](#) operation to edit a VCN on your Roving Edge Infrastructure devices.

Deleting a VCN from a Roving Edge Infrastructure Device

Describes how to delete a VCN on your Roving Edge Infrastructure device.

Using the Device Console

1. Open the navigation menu and select **Networking > Virtual Cloud Networks**. The **Virtual Cloud Networks** page appears. The single virtual cloud network (VCN) is listed in tabular form.
2. Click the VCN. The VCN's **Details** page appears.
3. Click **Terminate**.
4. Confirm the deletion when prompted.

Using the CLI

Use the `oci network vcn delete` command and required parameters to delete a VCN on your Roving Edge Infrastructure devices:

```
oci network vcn delete --vcn-id vcn_ocid [OPTIONS]
```

Refer to your Roving Edge Infrastructure device's CLI help for a list of parameters available for this command. See [Accessing Command Line Interface Help](#) on page 53.

For set up information regarding CLIs on your Roving Edge Infrastructure device, see [Using the Command Line Interface](#).

Using the API

Run the [DeleteVcn](#) operation to delete a VCN on your Roving Edge Infrastructure devices.

Subnets for Roving Edge Infrastructure Devices

Describes how to manage tasks for a subnet under a VCN on your Roving Edge Infrastructure device.

You can perform the following subnet tasks:

- [Creating a Subnet](#)
- [Listing Subnets](#)
- [Getting a Subnet's Details](#)
- [Editing a Subnet](#)
- [Deleting a Subnet](#)

See [Overview of VCNs and Subnets](#) in the Oracle Cloud Infrastructure documentation for more information on this feature.

Creating a Subnet

Describes how to create a subnet under the VCN on your Roving Edge Infrastructure device.

Using the Device Console

1. Open the navigation menu and select **Networking > Virtual Cloud Networks**. The **Virtual Cloud Networks** page appears. The single virtual cloud network (VCN) is listed in tabular form.
2. Click the VCN. The VCN's **Details** page appears.
3. Click **Create Subnet**. The **Create Subnet** dialog box appears.
4. Specify the resources to associate with the subnet. By default, the subnet is created in the root compartment, where you can also choose your resources.

Enter the following:

- **Name:** A friendly name for the subnet. It doesn't have to be unique, and it cannot be changed later in the Console (but you can change it with the API). Avoid entering confidential information.

- **CIDR Block:** A single, contiguous CIDR block for the subnet (for example, 172.16.0.0/24). Ensure that the CIDR block is within the cloud network's CIDR block and does not overlap with any other subnets. You cannot change this value later.
- **Use DNS Hostnames in this SUBNET:** This option is available only if you provided a DNS label for the VCN during creation. The option is required for assignment of DNS hostnames to hosts in the subnet. Enabling this option is required if you plan to use the VCN's default DNS feature (called the *Internet and VCN Resolver*).

If the check box is selected, you can specify a DNS label for the subnet, otherwise the Device Console generates one for you. The dialog box automatically displays the corresponding **DNS Label** for the subnet (<subnet_dns_label>.<vcn_dns_label>.oraclevcn.com).

- **DHCP Options:** The set of DHCP options to associate with the subnet.

5. Click **Create Subnet**. The subnet is then created and displayed on the **Subnets** page in the root compartment.

Using the CLI

Use the `oci network subnet create` command and required parameters to create a subnet under a VCN on your Roving Edge Infrastructure devices:

```
oci network subnet create --compartment-id compartment_ocid --vcn-id vcn_ocid --cidr-block cidr_block [OPTIONS]
```

To determine your Roving Edge Infrastructure device compartment OCID, see [Compartments](#).

Refer to your Roving Edge Infrastructure device's CLI help for a list of parameters available for this command. See [Accessing Command Line Interface Help](#) on page 53.

For set up information regarding CLIs on your Roving Edge Infrastructure device, see [Using the Command Line Interface](#).

Using the API

Run the `CreateSubnet` operation to create a subnet under a VCN on your Roving Edge Infrastructure devices.

Listing Subnets for a Roving Edge Infrastructure Device

Describes how to list the subnets under a VCN on your Roving Edge Infrastructure device.

Using the Device Console

1. Open the navigation menu and select **Networking > Virtual Cloud Networks**. The **Virtual Cloud Networks** page appears. The single virtual cloud network (VCN) is listed in tabular form.
2. Click the VCN. The VCN's **Details** page appears.
3. Click **Subnets**. All subnets are listed in tabular form.

Using the CLI

Use the `oci network subnet list` command and required parameters to list the subnets under a VCN on your Roving Edge Infrastructure devices:

```
oci network subnet list --compartment-id compartment_ocid [OPTIONS]
```

To determine your Roving Edge Infrastructure device compartment OCID, see [Compartments](#).

Refer to your Roving Edge Infrastructure device's CLI help for a list of parameters available for this command. See [Accessing Command Line Interface Help](#) on page 53.

For set up information regarding CLIs on your Roving Edge Infrastructure device, see [Using the Command Line Interface](#).

Using the API

Run the `ListSubnets` operation to list the subnets under a VCN on your Roving Edge Infrastructure devices.

Getting a Subnet's Details for a Roving Edge Infrastructure Device

Describes how to get the details of a subnet under a VCN on your Roving Edge Infrastructure device.

Using the Device Console

1. Open the navigation menu and select **Networking > Virtual Cloud Networks**. The **Virtual Cloud Networks** page appears. The single virtual cloud network (VCN) is listed in tabular form.
2. Click the VCN. The VCN's **Details** page appears.
3. Click **Subnets**. All subnets are listed in tabular form.
4. Click the subnet whose details you want to get. The subnet's **Details** page appears.

Using the CLI

Use the `oci network subnet get` command and required parameters to get the details of a subnet under a VCN on your Roving Edge Infrastructure devices:

```
oci network subnet get --subnet-id subnet_ocid [OPTIONS]
```

Refer to your Roving Edge Infrastructure device's CLI help for a list of parameters available for this command. See [Accessing Command Line Interface Help](#) on page 53.

For set up information regarding CLIs on your Roving Edge Infrastructure device, see [Using the Command Line Interface](#).

Using the API

Run the `GetSubnet` operation to get the details of a subnet under a VCN on your Roving Edge Infrastructure devices.

Renaming a Subnet for a Roving Edge Infrastructure Device

Describes how to rename a subnet under a VCN on your Roving Edge Infrastructure device.

Using the Device Console

1. Open the navigation menu and select **Networking > Virtual Cloud Networks**. The **Virtual Cloud Networks** page appears. The single virtual cloud network (VCN) is listed in tabular form.
2. Click the VCN. The VCN's **Details** page appears.
3. Click **Subnets**. All subnets are listed in tabular form.
4. Click the subnet whose details you want to get. The subnet's **Details** page appears.
5. Click **Edit**. The **Edit Subnet** dialog box appears.
6. Enter the new **Name** of the subnet.
7. Click **Save Changes**.

Using the CLI

Use the `oci network subnet update` command and required parameters to rename a subnet under a VCN on your Roving Edge Infrastructure devices:

```
oci network subnet update --subnet-id subnet_ocid [OPTIONS]
```

Refer to your Roving Edge Infrastructure device's CLI help for a list of parameters available for this command. See [Accessing Command Line Interface Help](#) on page 53.

For set up information regarding CLIs on your Roving Edge Infrastructure device, see [Using the Command Line Interface](#).

Using the API

Run the `UpdateSubnet` operation to rename a subnet under a VCN on your Roving Edge Infrastructure devices.

Deleting a Subnet from a Roving Edge Infrastructure Device

Describes how to delete a subnet under a VCN on your Roving Edge Infrastructure device.

If the subnet is empty, its state changes to **TERMINATING** briefly and then **TERMINATED**. If the subnet is not empty, you get an error indicating that instances or other resources contained within that you must delete first.

Using the Device Console

1. Open the navigation menu and select **Networking > Virtual Cloud Networks**. The **Virtual Cloud Networks** page appears. The single virtual cloud network (VCN) is listed in tabular form.
2. Click the VCN. The VCN's **Details** page appears.
3. Click **Subnets**. All subnets are listed in tabular form.
4. Click the subnet whose details you want to get. The subnet's **Details** page appears.
5. Click **Terminate**.
6. Confirm the deletion when prompted.

Using the CLI

Use the `oci network subnet delete` command and required parameters to delete a subnet under a VCN on your Roving Edge Infrastructure devices:

```
oci network subnet delete --subnet-id subnet_ocid [OPTIONS]
```

Refer to your Roving Edge Infrastructure device's CLI help for a list of parameters available for this command. See [Accessing Command Line Interface Help](#) on page 53.

For set up information regarding CLIs on your Roving Edge Infrastructure device, see [Using the Command Line Interface](#).

Using the API

Run the [DeleteSubnet](#) operation to delete a subnet under a VCN on your Roving Edge Infrastructure devices.

Virtual Network Interface Cards (VNICs)

Describes how to manage tasks for a virtual network interface card (VNIC) in a virtual cloud network (VCN), including creating, updating, and deleting VNICs, on your Roving Edge Infrastructure devices.

You can perform the following VNIC tasks:

- [Creating and attaching a VNIC](#)
- [Getting a VNIC's details](#)
- [Editing a VNIC](#)
- [Getting a VNIC attachment's details](#)
- [Detaching and Deleting a VNIC](#)

See [Virtual Network Interface Cards \(VNICs\)](#) in the Oracle Cloud Infrastructure documentation for more information on this feature.

Creating and Attaching a Secondary VNIC

Describes how to create and attach a secondary VNIC to your Roving Edge Infrastructure devices.

Using the Device Console

1. Open the navigation menu and select **Compute > Instances**. The **Instances** page appears. All instances are listed in tabular form.
2. (optional) Select a **State** from the list to limit the instances displayed to that state.
3. Click the instance that you want to create and attach a secondary VNIC. The instance's **Details** page appears.
4. Under **Resources**, click **Attached VNICs**. The primary VNIC and any secondary VNICs attached to the instance are displayed.
5. Click **Create VNIC**. The **Create VNIC** dialog box appears.
6. Complete the following:
 - **Name:** Enter a name for the secondary VNIC.
 - **Virtual cloud network:** Select the VCN that contains the subnet of interest from the list.

- **Subnet:** Select the subnet of interest from the list. The secondary VNIC must be in the same availability domain as the instance's primary VNIC, so the subnet list includes any regional subnets or AD-specific subnets in the primary VNIC's availability domain.
 - **Private IP Address:** Enter an available private IP address of your choice from the subnet's CIDR (otherwise the private IP address is automatically assigned).
 - **Assign a public IP address:** Specify whether to assign a public IP address to the VNIC's primary private IP. Available only if the subnet is public. Choose this option to specify an existing reserved public IP address by name, or to create a new reserved IP address by assigning a name and selecting a source IP pool for the address. If you do not select an IP pool have created, the default Oracle IP pool is used.
 - **Hostname:** Enter a hostname to be used for DNS within the cloud network. Available only if the VCN and subnet both have DNS labels.
7. Click **Submit**. The secondary VNIC is created and then displayed on the **Attached VNICs** page for the instance. It can take several seconds before the secondary VNIC appears on the page.
 8. Configure the operating system to use the VNIC.

Using the CLI

Use the `oci compute instance attach-vnic` command and required parameters to create and attach a secondary VNIC to your Roving Edge Infrastructure devices:

```
oci compute instance attach-vnic --instance-id instance_ocid [OPTIONS]
```

To determine your Roving Edge Infrastructure device compartment OCID, see [Compartments](#).

Refer to your Roving Edge Infrastructure device's CLI help for a list of parameters available for this command. See [Accessing Command Line Interface Help](#) on page 53.

For set up information regarding CLIs on your Roving Edge Infrastructure device, see [Using the Command Line Interface](#).

Using the API

Run the `AttachVnic` operation to create and attach a secondary VNIC to your Roving Edge Infrastructure devices.

Getting a VNIC's Details

Describes how to get the details of a VNIC on your Roving Edge Infrastructure devices.

Use this command to get the VNIC's private IP address, MAC address, optional public IP address, optional DNS hostname, and other properties.

Using the Device Console

1. Open the navigation menu and select **Compute > Instances**. The **Instances** page appears. All instances are listed in tabular form.
2. (optional) Select a **State** from the list to limit the VCNs displayed to that state.
3. Click the instance associated with the VNIC to which you want to assign a secondary private ID. The instance's **Details** page appears.
4. Click **Attached VNICs** under **Resources**. The primary VNIC is listed. If the instance has two **active physical NICs**, the VNICs are grouped by NIC 0 and NIC 1.
5. Click the VNIC whose details you want to get. The VNIC's **Details** page appears.

Using the CLI

Use the `oci network vnic get` command and required parameters to get the details of a VNIC on your Roving Edge Infrastructure devices:

```
oci network vnic get --vnic-id vnic-ocid [OPTIONS]
```

Refer to your Roving Edge Infrastructure device's CLI help for a list of parameters available for this command. See [Accessing Command Line Interface Help](#) on page 53.

For set up information regarding CLIs on your Roving Edge Infrastructure device, see [Using the Command Line Interface](#).

Using the API

Run the [GetVnic](#) operation to get the details of a VNIC on your Roving Edge Infrastructure devices.

Editing a VNIC

Describes how to edit a VNIC on your Roving Edge Infrastructure devices.

Using the Device Console

1. Open the navigation menu and select **Compute > Instances**. The **Instances** page appears. All instances are listed in tabular form.
2. (optional) Select a **State** from the list to limit the VCNs displayed to that state.
3. Click the instance associated with the VNIC you want to edit. The instance's **Details** page appears.
4. Click **Attached VNICs** under **Resources**.
5. Click the VNIC you want to edit. The VNIC's **Details** page appears.
6. Click the Actions menu (⋮) to the right of the VNIC entry and select **Edit**. The **Edit VNIC** dialog box appears.
7. Make your edits. See [Creating and Attaching VNICs](#) for descriptions of the settings
8. Click **Save Changes**.

Using the CLI

Use the `oci network vnic update` command and required parameters to edit a VNIC on your Roving Edge Infrastructure devices:

```
oci network vnic update --vnic-id vnic-ocid [OPTIONS]
```

Refer to your Roving Edge Infrastructure device's CLI help for a list of parameters available for this command. See [Accessing Command Line Interface Help](#) on page 53.

For set up information regarding CLIs on your Roving Edge Infrastructure device, see [Using the Command Line Interface](#).

Using the API

Run the [UpdateVnic](#) operation to edit a VNIC on your Roving Edge Infrastructure devices.

Detaching and Deleting a VNIC

Describes how to detach and delete a secondary VNIC from your Roving Edge Infrastructure devices.

Using the Device Console

1. Open the navigation menu and select **Compute > Instances**. The **Instances** page appears. All instances are listed in tabular form.
2. (optional) Select a **State** from the list to limit the instances displayed to that state.
3. Click the instance that you want to detach and delete a secondary VNIC. The instance's **Details** page appears.
4. Click **Attached VNICs** under **Resources**.
The primary VNIC and any secondary VNICs attached to the instance are displayed.
5. Click the Actions menu (⋮) to the right of the secondary VNIC you want to delete and select **Delete VNIC**.
6. Confirm the detachment when prompted.

It takes typically a few seconds before the VNIC is deleted.

Using the CLI

Use the `oci compute instance detach-vnic` command and required parameters to detach and delete a secondary VNIC from your Roving Edge Infrastructure devices:

```
oci compute instance detach-vnic --compartment-id compartment_ocid --vnic-id vnic-ocid [OPTIONS]
```

To determine your Roving Edge Infrastructure device compartment OCID, see [Compartments](#).

Refer to your Roving Edge Infrastructure device's CLI help for a list of parameters available for this command. See [Accessing Command Line Interface Help](#) on page 53.

For set up information regarding CLIs on your Roving Edge Infrastructure device, see [Using the Command Line Interface](#).

Using the API

Run the [DetachVnic](#) operation to detach and delete a secondary VNIC from your Roving Edge Infrastructure devices.

Listing VNIC Attachments

Describes how to list the VNIC attachments on your Roving Edge Infrastructure devices.

Using the Device Console

1. Open the navigation menu and select **Compute > Instances**. The **Instances** page appears. All instances are listed in tabular form.
2. (optional) Select a **State** from the list to limit the instances displayed to that state.
3. Click the instance that you want to list VNIC attachments. The instance's **Details** page appears.
4. Click **Attached VNICs** under **Resources**. The primary VNIC is listed. If the instance has two active physical NICs, the VNICs are grouped by NIC 0 and NIC 1.

Using the CLI

Listing the VNIC attachments for a compartment

Use the `oci compute vnic-attachment list` command and required parameters to list the VNIC attachments on your Roving Edge Infrastructure devices:

```
oci compute vnic-attachment list --compartment-id compartment_ocid [OPTIONS]
```

To determine your Roving Edge Infrastructure device compartment OCID, see [Compartments](#).

Refer to your Roving Edge Infrastructure device's CLI help for a list of parameters available for this command. See [Accessing Command Line Interface Help](#) on page 53.

For set up information regarding CLIs on your Roving Edge Infrastructure device, see [Using the Command Line Interface](#).

Listing VNIC attachments for an instance

Use the `oci compute instance list-vnics` command and required parameters to list the VNIC attachments on your Roving Edge Infrastructure devices:

```
oci compute instance list-vnics [OPTIONS]
```

To determine your Roving Edge Infrastructure device compartment OCID, see [Compartments](#).

Refer to your Roving Edge Infrastructure device's CLI help for a list of parameters available for this command. See [Accessing Command Line Interface Help](#) on page 53.

For set up information regarding CLIs on your Roving Edge Infrastructure device, see [Using the Command Line Interface](#).

Using the API

Use the [ListVnicAttachments](#) operation to list the VNIC attachments on your Roving Edge Infrastructure devices.

Getting a VNIC Attachment's Details

Describes how to get the details of a VNIC attachment on your Roving Edge Infrastructure devices.

Use this command to get the VNIC's VLAN tag and other properties.

Using the Device Console

1. Open the navigation menu and select **Compute > Instances**. The **Instances** page appears. All instances are listed in tabular form.
2. (optional) Select a **State** from the list to limit the VCNs displayed to that state.
3. Click the instance associated with the VNIC to which you want to assign a secondary private ID. The instance's **Details** page appears.
4. Click **Attached VNICs** under **Resources**. The primary VNIC is listed.
5. Click the VNIC whose details you want to get. The VNIC's **Details** page appears.

Using the CLI

Use the `oci compute vnic-attachment get` command and required parameters to get the details of a VNIC attachment on your Roving Edge Infrastructure devices:

```
oci compute vnic-attachment get --vnic-attachment-id vnic-attachment-ocid  
[OPTIONS]
```

Refer to your Roving Edge Infrastructure device's CLI help for a list of parameters available for this command. See [Accessing Command Line Interface Help](#) on page 53.

For set up information regarding CLIs on your Roving Edge Infrastructure device, see [Using the Command Line Interface](#).

Using the API

Run the [GetVnicAttachment](#) operation to get the details of a VNIC attachment on your Roving Edge Infrastructure devices.

Events for Roving Edge Infrastructure Devices

Describes how to manage events, including creating, updating, and deleting events, on your Roving Edge Infrastructure devices.

You can perform the events management tasks:

- [Creating an Events Rule](#)
- [Listing Events Rules](#)
- [Getting the Details of an Events Rule](#)
- [Editing an Events Rule](#)
- [Enabling an Events Rule](#)
- [Disabling an Events Rule](#)
- [Deleting an Events Rule](#)

See [Events](#) in the Oracle Cloud Infrastructure documentation for more information on this feature.

Creating an Events Rule for a Roving Edge Infrastructure Device

Describes how to create an events rule on your Roving Edge Infrastructure device.

Using the Device Console

1. Open the navigation menu and select **Events > Rules**. The **Rules** page appears. All events rules are listed in tabular form.
2. Click **Create Rule**. The **Create Rule** dialog box appears.
3. Enter the following:
 - **Display Name**: Specify a friendly name for the rule. You can change this name later. Avoid entering confidential information.
 - **Description**: Specify a description of what the rule does. You can change this description later.
4. Under **Rule Conditions**, complete the following:

To add an event type:

 - a. Select **Event Type** from **Condition**.
 - b. Select a **Service Name**.
 - c. In **Event Type**, select one or more event types for this service.

To add an attribute:

You must first have already created an event type rule condition before you can add an attribute.

 - a. Select **Attribute** from **Condition**.
 - b. Select an **Attribute Name**.
 - c. Select or enter attribute values from **Attribute Values**. Attribute values are optional.

Click + **Another Condition** to add another rule condition.
5. Under **Actions**, specify the trigger for the specified event conditions:
 - a. Select the **Action Type** from the list. Options are HTTP and HTTPS.
 - b. Select the **URL** of the action.
 - c. Click + **Another Action** and select **Event Type** to add another action for the rule condition.
6. Click **Create Rule**.

The Create Rule dialog box closes and you are returned to the Rule page. The events rule you created is listed with the other ones.

Using the CLI

Use the `oci events rule create` command and required parameters to create an events rule on your Roving Edge Infrastructure devices:

```
oci events rule create --compartment-id compartment_ocid --
condition condition --actions actions [OPTIONS]
```

To determine your Roving Edge Infrastructure device compartment OCID, see [Compartments](#).

Refer to your Roving Edge Infrastructure device's CLI help for a list of parameters available for this command. See [Accessing Command Line Interface Help](#) on page 53.

For set up information regarding CLIs on your Roving Edge Infrastructure device, see [Using the Command Line Interface](#).

Using the API

Run the `CreateRule` operation to create an Events rule on your Roving Edge Infrastructure devices.

Listing Events Rules for a Roving Edge Infrastructure Device

Describes how to list the events rules on your Roving Edge Infrastructure device.

Using the Device Console

Open the navigation menu and select **Events > Rules**.

The Rules page appears. All events rules are listed in tabular form.

Using the CLI

Use the `oci events rule list` command and required parameters to list the events rules on your Roving Edge Infrastructure devices:

```
oci events rule list --compartment-id compartment_ocid [OPTIONS]
```

To determine your Roving Edge Infrastructure device compartment OCID, see [Compartments](#).

Refer to your Roving Edge Infrastructure device's CLI help for a list of parameters available for this command. See [Accessing Command Line Interface Help](#) on page 53.

For set up information regarding CLIs on your Roving Edge Infrastructure device, see [Using the Command Line Interface](#).

Using the API

Run the `ListRules` operation to list the Events rules on your Roving Edge Infrastructure devices.

Getting an Events Rule's Details for a Roving Edge Infrastructure Device

Describes how to get the details of an events rule on your Roving Edge Infrastructure device.

Using the Device Console

1. Open the navigation menu and select **Events > Rules**. The **Rules** page appears. All events rules are listed in tabular form.
2. Select the events rule whose details you want to get. The events rule's **Details** page appears.

The **Details** page contains information about the events rule, both general information and links to its resources. Some items in the page are read-only, while other items allow you to edit and update the events rule.

Using the CLI

Use the `oci events rule get` command and required parameters to get the details of an events rule on your Roving Edge Infrastructure devices:

```
oci events rule get --rule-id rule_ocid [OPTIONS]
```

Refer to your Roving Edge Infrastructure device's CLI help for a list of parameters available for this command. See [Accessing Command Line Interface Help](#) on page 53.

For set up information regarding CLIs on your Roving Edge Infrastructure device, see [Using the Command Line Interface](#).

Using the API

Run the `GetRule` operation to get the details of an Events rule on your Roving Edge Infrastructure devices.

Editing an Events Rule for a Roving Edge Infrastructure Device

Describes how to edit an events rule on your Roving Edge Infrastructure device.

Using the Device Console

1. Open the navigation menu and select **Events > Rules**. The **Rules** page appears. All events rules are listed in tabular form.
2. Select the events rule that you want to edit. The events rule's **Details** page appears.
3. Click **Edit Rule**. The **Edit Rule** dialog box appears.
4. Edit the events rule's settings. See [Creating an Events Rule](#) for descriptions of each setting.
5. Click **Save Changes**.

The **Edit Rule** dialog box closes. The updates you made are present in the details of the events rule.

Using the CLI

Use the `oci events rule update` command and required parameters to edit an events rule on your Roving Edge Infrastructure devices:

```
oci events rule update --rule-id rule_ocid [OPTIONS]
```

Refer to your Roving Edge Infrastructure device's CLI help for a list of parameters available for this command. See [Accessing Command Line Interface Help](#) on page 53.

For set up information regarding CLIs on your Roving Edge Infrastructure device, see [Using the Command Line Interface](#).

Using the API

Run the [UpdateRule](#) operation to edit an Events rule on your Roving Edge Infrastructure devices.

Enabling an Events Rule for a Roving Edge Infrastructure Device

Describes how to enable an events rule on your Roving Edge Infrastructure device.

Using the Device Console

1. Open the navigation menu and select **Events > Rules**. The **Rules** page appears. All events rules are listed in tabular form.
2. Select the events rule that you want to edit. The events rule's **Details** page appears.
3. Click **Enable**.
4. Confirm the enabling of the events rule.

The **Rules** page displays the rule as enabled.

Disabling an Events Rule for a Roving Edge Infrastructure Device

Describes how to disable an events rule on your Roving Edge Infrastructure device.

Using the Device Console

1. Open the navigation menu and select **Events > Rules**. The **Rules** page appears. All events rules are listed in tabular form.
2. Select the events rule that you want to edit. The events rule's **Details** page appears.
3. Click **Disable**.
4. Confirm the disabling of the events rule.

The **Rules** page displays the rule as disabled.

Deleting an Events Rule for a Roving Edge Infrastructure Device

Describes how to delete an events rule from your Roving Edge Infrastructure device.

Using the Device Console

1. Open the navigation menu and select **Events > Rules**. The **Rules** page appears. All events rules are listed in tabular form.
2. Select the events rule that you want to delete. The events rule's **Details** dialog box appears.
3. Click **Delete Rule**.
4. Confirm the deletion when prompted.

The list of events rules reappears without the rule you deleted.

Using the CLI

Use the `oci events rule delete` command and required parameters to delete an events rule from your Roving Edge Infrastructure devices:

```
oci events rule delete --rule-id rule_ocid [OPTIONS]
```

Refer to your Roving Edge Infrastructure device's CLI help for a list of parameters available for this command. See [Accessing Command Line Interface Help](#) on page 53.

For set up information regarding CLIs on your Roving Edge Infrastructure device, see [Using the Command Line Interface](#).

Using the API

Run the `DeleteRule` operation to delete an Events rule from your Roving Edge Infrastructure devices.

Returning Devices to Oracle

Describes the procedure for returning a Roving Edge Infrastructure device back to Oracle.

Return your Roving Edge Infrastructure devices to Oracle when you no longer need them, or because of a technical issue that requires sending it back for repair and replacement.

Contacting Oracle for Device Return

When you are ready to return your Roving Edge Infrastructure devices to Oracle, contact My Oracle Support to arrange the pickup and delivery. See [Getting Help and Contacting Support](#).

Preparing Devices for Return

Before returning your Roving Edge Infrastructure devices to Oracle, delete all workloads and data on each device by performing the following tasks in order:

- Delete all data objects residing in the object storage buckets. See [Deleting an Object](#).
- Delete all object storage buckets. Delete all the objects they contain before deleting the buckets themselves. See [Deleting a Bucket](#).
- Delete all block volumes. See [Deleting a Block Volume](#).
- Delete all users. Deleting a user resource also deletes any associated client credentials. See [Deleting a User](#).
- Terminate all compute virtual machine (VM) instances and remove all VM images. See [Terminating an Instance](#) and [Removing an Instance](#).

Important:

Ensure you have synced all your needed data to Oracle Cloud Infrastructure using Data Sync before deleting it from your devices. See [Data Sync Tasks](#).

Successfully completing these tasks before returning the devices to Oracle complies with your terms and conditions.

Returning Non-Working Devices

Contact My Oracle Support (MOS) if your Roving Edge Infrastructure devices is not working because of damage or any other type of failure. MOS determines whether the device is repairable onsite. If onsite repair is not possible, you will receive a replacement device with instructions on how return or destroy the non-working device.

Note:

You might incur fees for the non-working device as described in your rate card documentation.

Troubleshooting

Use troubleshooting information to identify and address common issues that can occur while working with Roving Edge Infrastructure.

General

Getting Oracle Support

If after reviewing and using these troubleshooting tips you still need help, open a service request for your issue. See [Open a Support Ticket](#) for more information.

Device is locked again

Roving Edge Infrastructure devices require that you unlock them after every reboot and power cycle. If the RED is unexpectedly locked, verify that the power connection is steady, and check if it was recently restarted. Check that the power connection is steady and that the Roving Edge Infrastructure device did not restart.

Exiting the Serial Console

Disconnect the Serial Console by inputting the following in sequential order: **Enter**, ~ (tilde), . (period).

Device Console URL gives "unavailable" or "not trusted" message

The Device Console communicates with TLS/HTTPS on port 8015 of each Roving Edge Infrastructure device. When your browser displays a security warning indicating the URL is unavailable or is not a trusted URL, ensure that the TLS certificate is installed and trusted on their machine.

If the Device Console's TLS certificate is not installed and trusted on your host computer, add the TLS certificate from the Device Console using the browser to your host computer's keychain/certificate collection and mark it as trusted. In browsers such as Chrome, Edge, and Firefox, the TLS certificate resides in the browser window to the left of the URL. Consult your particular browser's documentation for more information on how to download the certificate.

An "unavailable" or "not trusted" message might also occur if the system is partially down. Examples include when rebooting for a system upgrade or starting for the first time after a power outage. To help diagnose whether the issue is related to the TLS certificate or a system outage, check for a good or bad response to the `https://<host>:12060/v1/tenants/orei` endpoint in the operator's browser or with a tool like CURL. If accessing that endpoint results in a security warning, check that the Roving Edge Infrastructure device's TLS certificate is properly installed and trusted. If the endpoint times out or returns a non-200 response the system might be experiencing a partial outage.

Browser Security Warning When Accessing the Device Console

The Device Console communicates with TLS/HTTPS on port 8015 of a given device. When the Device Console browser displays a security warning, ensure that the TLS certificate is installed and trusted on your Roving Edge Infrastructure device. If the Device Console's TLS certificate is not installed and trusted on the host computer, add the

TLS certificate from the Device Console in the browser to the host computer's keychain/certificate collection. Then mark it as trusted. In browsers such as Chrome, Edge, and Firefox, the TLS certificate resides in the browser window to the left of the URL. Consult your browser documentation for more information on how to download the certificate.

"Service unknown" when creating policies for "service rover"

If you get the error "Service unknown" when creating policies for "service rover," you might need to create a child tenancy in Oracle Cloud Infrastructure. See [Creating a New Child Tenancy](#) in the Oracle Cloud Infrastructure documentation for more information on this feature.

System Upgrade

System Upgrade loading icon keeps spinning

The System Upgrade tool persists in its loading state until a timeout occurs, after which it indicates that the system upgrade status cannot be determined. This timeout occurs most often when the REDs are disconnected from the internet. The System Upgrade requires a connection to OCI to determine whether an upgrade for the RED is available.

If your device is disconnected from the internet, you can update your device using the disconnected upgrade process. See [Updating the Roving Edge Infrastructure Device Software while Disconnected](#) on page 155 for more information.

System Upgrade bundle download process fails

Check your internet connection and press **Download Upgrade** to attempt the download. If the download is not successful after multiple attempts, reach out to Oracle support for help.

Networking

IP address range for the public IP pool configuration does not get submitted

After typing an IP range and pressing **Enter**, press **Enter** again on the blank input line to submit. If more IP ranges are required, press **Enter** after each range to open another line of input. Submit a blank input line as the last entry to submit everything. To cancel and go back, press **Ctrl+C**.

Cannot access public service endpoints (169.254.169.254 at ports 8015, 18336, and so forth)

Ensure that the firewall on the instance does not block the 196.254.0.0/16 address range. It is common for an OCI-exported image to block link-local address range by default. If so, remove the rule that is blocking any connections to 196.254.0.0/16 from the firewall settings. Consult your operating system documentation regarding firewall configuration procedure.

Storage

Lack of available storage space causes block volume operations to fail

Lack of available storage space might cause block storage operations to fail. Free up space by deleting resources that are no longer needed, such as Object Storage objects, boot and block volumes, and VMs. Regularly check your REDs' available storage to ensure you are not at risk of running out. See [Roving Edge Infrastructure Device Monitoring](#) on page 148 for more information.

Low object storage available capacity triggers warnings and read-only

When the system reaches 80% capacity used, it triggers a **Warning** status in the Monitoring page. When the system reaches 95% capacity used, it enters read-only mode, and the Monitoring page shows Object Storage status as **Degraded** or **Warning**.

Oracle recommends avoiding running intensive writing operations when the system is functioning at 80% capacity used. If you are at or close to 80%, transfer data to the OCI cloud until the system is well below 80% capacity.

If the system exceeds 95% capacity used threshold, it enters read-only mode, and core functionality (including Compute and Object Storage) is limited. All Compute operations, such as custom VMs, boot volumes, and block volumes, and all Object Storage operations are suspended. The suspension of the system prevents you from writing to a storage device when durability and redundancy cannot be guaranteed.

If no available storage space remains on the device, you can free more space by deleting resources that are no longer needed, such as objects in Object Storage, boot and block volumes, and VMs. If delete requests fail because no storage space remains and the system is in read-only mode, you can activate Safe Mode through the Serial Console. Safe Mode permits you to make the necessary deletions.

Avoiding oversubscribing storage problems

Follow best practice recommendations on how to set up or plan Compute, Block Storage, and Object Storage resource consumption to avoid oversubscription problems. Block Storage and Compute do not reserve storage space for volumes in advance. Instead, storage space is consumed when data is written to the volume. For example, if a 100 GB block volume is created, it does not mean that 100 GB is reserved from the total available storage space for this volume. The storage space remains available to all services and can be exhausted before the 100 GB volume is filled with data.

Also, Compute and Block Storage do not validate the specified size of a created volume against the available storage space. This lack of validation can lead to oversubscription when the total size of created volumes exceeds the storage space available on the device. Do not rely on block volume sizes to calculate storage space utilization. Instead, follow the information about storage space usage displayed in the Device Console's Monitoring page.

Monitoring page shows Object Storage status as "Degraded" or "Warning"

If the storage function within a RED malfunctions or has physical problems, the Monitoring page on the Device Console might show the **Warning** or **Degraded** status periodically for the Object Storage service. If this situation occurs, the RED attempts to rebalance its storage and recover declared redundancy level. Eventually it shows a healthy state if RED has available space and is able to recover enough redundant copies on remaining the RED devices being used for storage.

Image import from Object Storage to Compute is taking a long time

If an image does not appear in the **Custom Images** list, the import has failed. If the import fails, check the device nodes **Details** page:

1. Open the navigation menu and select **Node Management > Nodes**. The **Nodes** page appears, displaying the service and feature status of all your devices in tabular format.
2. Select the node whose status you want to monitor and view its **Details** page.
3. Click the **Storage** tab and review what percentage of the device of storage has been used.

If the Object Storage service is not healthy, the **Monitoring** page displays **Degraded** or **Warning** as the status. If Object Storage is healthy, check the **Monitoring** page to ensure that enough available space exists. If insufficient space is available, remove any images, objects, VMs, and other items to make room for the wanted image.

Objects with certain version IDs can cause problems

Running a CLI command where the object's version ID starts with a dash ("-") and contains the characters **h** or **i** causes the CLI to enter interactive mode. For example:

```
oci os object get ... --version-id '-WhjCQ.-IYgDLuoZ9gbxpn.8Q.q-iZt' ...
```

If this occurs, you can use one of the following workarounds:

- Include the equal sign ("=") between the `--version-id` parameter and its value. Do not include any spaces before or after the `=`. For example:

```
oci os object get ... --version-id="-WhjCQ.-IYgDLuoZ9gbxpn.8Q.q-iZt" ...
```

Only use double-quotes around the value.

- Include the `--from-json` parameter in the command and specify the input in a JSON format. See [Advanced JSON Options](#) for more information.

Compute/Instances

Instance creation attempt results in "Out of Capacity" message

Instance capacity is limited by the number of available cores and available memory. Terminate some of the existing instances that are not in use and try again. Stopped instances count toward the resources used.

Image Import Failure

Large images take a while to import, much longer if other disk-heavy applications or operations are on going. If an import is taking too long and you want to end it, select **Terminate** from the **Import** menu. An image import will automatically time out and cancel after four hours.

VM launches into Running state, but upon connection looping on some boot messages

Roving Edge Infrastructure only supports `.oci` and `.qcow2` images, with UEFI booting. To check for image-related problems, open the Device Console and go to the Details page of the compute VM instance. Check whether the image format is `.oci`, `.qcow2`, or another type. Images exported from OCI cloud are usually `.oci` type. Confirm the image and boot type with the provider of the image.

On a Linux machine, use the `qemu-img` utility to see image info using the following command:

```
qemu-img info image_file
```

Cannot Access External Resource from VM Instance

1. If the domain name is referencing an external resource, ensure that external DNS resolvers are added to the list of nameservers inside the instance. Consult your operating system documentation regarding DNS configuration procedure.

For example, on some Linux-based systems, nameserver IPs needs to be added to `/etc/resolv.conf` file.

2. Ensure that the RED external connectivity settings are correct. See [Administering Devices](#) on page 37
3. Ensure that the instance firewall settings do not block outgoing connections. Consult your operating system documentation regarding firewall configuration procedures.

Cannot Connect to VM Instance Using SSH

1. Ensure that the VM instance is running. Open the Device Console and check the Details page of the compute VM instance page to ensure that the instance state is **RUNNING**. If the instance is not running, enter **Start** to launch the instance. Wait for state to change to **RUNNING**.
2. Ensure that the VM instance has public IP address assigned. Open the Device Console and go to the Details page of the compute VM instance. Click the instance name and verify that the instance has public IP assigned by reviewing **Public IP Address** value under **Instance Access** section.

If the instance does not have a public IP assigned, add one using the following steps:

- a. Open the Details page of the compute VM instance.
- b. Click **Attached VNICs** under **Resources** to display the list of attached VNICs.
- c. Select the primary VNIC.

- d. The Details page for the primary VNIC appears.
- e. Click **Edit**.

Alternately, select the Actions menu (⋮) for the VNIC you want to edit and click **Edit**.

The Edit VNIC dialog box appears.

- f. Select the **Ephemeral Public IP** option.
 - g. Click **Update**.
 - h. If public IP assignment fails, open the Serial Console and select **Network Configuration** to ensure that the RED's public IP address pool is set up and has IPs available.
3. Ensure that RED external connectivity settings are correct. Open the Serial Console and select **Configuring Devices**. Ensure the RED's IP address, network prefix length, and gateway IP address are set up correctly.
 4. Ensure that the VM instance is reachable through ICMP requests. Run following command:

```
ping 100.100.1.10
```

where 100.100.1.10 is target instance's public IP address. If the command is successful, the problem might be with instance configuration (SSH service, firewall rules). Consult your operating system documentation regarding SSH and firewall setup for more information.

5. Ensure that the VM instance has started correctly. If running the `ping 100.100.1.10` command is not successful, check the instance console history to look for a successful start sequence. See [Console History Capture](#) on page 216.
6. Reboot the node using the device's power button or through the Serial Console.

Cannot Access a Port on a VM Instance From the External Machine

1. Ensure that RED external connectivity settings are correct. See [Administering Devices](#) on page 37.
2. Ensure that instance firewall settings do not block incoming connections. Consult your operating system documentation regarding firewall configuration procedure.
3. Ensure that the public IP address is accessing the VM instance, not the private IP address or fully qualified domain name (FQDN). Instance private IP address is visible only inside VCN subnet. Instance FQDN is visible only when the default VCN internal DNS service is being used (169.254.169.254), which is not accessible outside of the VCN network.

Cannot access VM instance from another instance

1. Ensure that the target instance is running. Open the Device Console and check the Details page of the compute VM instance to ensure that the target instance state is **Running**.
2. Ensure that the request-sending instance has its network configuration, such as IP address, network mask, and gateway, set up correctly. Follow the subnet settings guidelines when performing the configuration. Consult your operating system documentation regarding network configuration for more information.

On Linux-based systems, verify the setup using the following command:

```
ip addr show ip route show default
```

3. Ensure that the target instance firewall settings do not block incoming connections. Consult your operating system documentation regarding firewall configuration procedure for more information.
4. Ensure that the request-sending instance firewall settings do not block outgoing connections. Consult your operating system documentation regarding firewall configuration procedure.
5. If ICMP is not blocked on the target instance, ensure the `ping` command is successful. Run the following command from the request-sending instance shell:

```
ping 10.0.0.2
```

where 10.0.0.2 is the target instance's private IP.

6. If the `ping` command result is `No route to host`, ensure that the default route is set to subnet gateway. Consult your operating system documentation regarding default route settings. For example, for Linux-based operating systems, the command might be:

```
ip route show default
```

with the expected output:

```
default via 10.0.0.1 dev eth0
```

where `10.0.0.1` is `10.0.0.0/24` subnet's gateway IP address (VCN subnet gateway always uses the first address in the subnet range).

Cannot access another VM instance by fully qualified domain name

Ensure that the target instance is running. Open the Device Console and check the Details page of the compute VM instance to ensure that the target instance state is **Running**. If the target instance is **Stopped**, restart it. Confirm that the request-sending instance has `169.254.169.254` set as a nameserver. Consult your operating system documentation regarding DNS configuration procedure for any questions.

VM launches, but there's no public IP address to connect to using SSH

When creating a VM instance, select the **Assign a public IP address** option. Ensure that the public IP pool specified during device setup (using the Serial Console) has enough addresses for the number of VMs (including ones in **Stopped** state). If not enough addresses exist, terminate some VMs to free up addresses, or create more public IPs using the Serial Console.

VM creation goes right to Terminating state

This is likely because of one of the following:

- **Lack of public IPs:** Lack of IPs can occur because of the public IP pool not being set up in the Serial Console, or is out of IPs for some other undetermined reason. Check that the RED's public IP pool range has been set (if creating a VM with the default option of public IP):
 1. Open the Serial Console.
 2. Select **Configure Networking** (option 3).
 3. Select **Display Public IP Pool Status** (option 4).

If the public IP pool has not been set, go back and select **Public IP Pool Range for Compute Instances**.

Follow the displayed instructions to input public IP ranges. The Serial Console includes a usage guide for more information.

- **Full ceph object/block storage:** The inability to allocate space for the VM's boot volume can cause the VM to enter the Termination state. Ensure that the object/block storage is not full by checking the top of the Monitoring page in the RED console.
- **Full CPU usage:** There exists a maximum of 32 OCPUs in total across VMs, including those OCPUs that are stopped. On the Device Console's Compute page, ensure that the total OCPU count of existing VMs is less than the maximum of 32. If all 32 OCPUs are being used, terminate some instances to free up resources.
- **Full GPU usage:** There exists a maximum of one GPU-shape VM, including those GPUs that are stopped. A RED can only have a single GPU-shaped VM provisioned at a time. Attempts to create more GPU-shape instances terminate during provisioning. On the Device Console's Compute page, ensure that there are no instances with GPU shape in **Running** or **Stopped** state. If a GPU shaped instance exists, terminate it.
- **Invalid image:** Roving Edge Infrastructure only supports `.oci` and `.qcow2` image formats, with UEFI booting. On the Device Console's Compute page, open the **Instances** section and determine which VM is terminating. Click the terminating VM to open its Details page, where you can note the image name. The image name and extension indicates whether it is `.oci` or `.qcow2` or another type. Images exported from OCI cloud are usually `.oci` type. Verify the image and boot type with the person who provided the image.

On a Linux machine, use the `qemu-img` utility to see image info using the following command:

```
qemu-img info image_file
```

Slow VM performance or slow terminal usage using SSH

Slow RED performance can result when other VMs are experiencing heavy usage, such as those running disk- or network-intensive applications. Resource-heavy device operations, such as importing large object storage contents or compute images, can also degrade performance. If you are working with an intensive application, use a VM shape with higher OCPU count, as they also come with more RAM. Stop or terminate the current VM, then create another VM using the same image, but with the bigger shape.

Your VM launches into Running state, but the SSH rejects your key, refuses connection, or times out.

If you launch a VM whose state listed as **Running**, but SSH rejects your key, refuses the connection, or times out, try the following:

- Ensure that you are trying to connect to the VM's public IP address using SSH.
- Ensure that you are using the private key (not public) as part of the SSH command on your host computer.
- Give the VM a minute or longer to fully launch. Providing this time allows the SSH service to load. Then try again to connect.
- In rare cases, if the image your uploaded or imported already contains public user SSH keys, the new keys uploaded or copy/pasted as part of the VM creation process might not be included. Take a snapshot of the original image with the wanted keys added, and use that modified image.

VM instance stuck for a long time

Provisioning of certain images and resources, such as boot volumes, GPU, and bigger shapes, can take 10 minutes or more. If a VM instance has been stuck for a long time, do the following:

1. Access the Device Console and open the Details page for the instance.
2. Review the **Attached Block Volumes** and **Attached VNICs** sections, and note any resources stuck in **Attaching** or **Detaching** state.
3. If any block volumes or VNICs are seen stuck in attaching/detaching state, check the Monitoring page to see if Block Storage and VCN services are healthy.
 - If used storage space is nearly full, there might not be enough capacity to provision an instance. Consider terminating other instances, removing block volumes, or both to free up space.
 - If the public IP pool is used up, provisioning a new instance with public IP (specified by default) isn't doable. Either terminate existing instances to free up IPs, or add public IPs using the Serial Console.
4. Review the Monitoring page for any other services are unhealthy.

If the solutions listed in here do not solve the issue, consider terminating the instance.

Stuck instances will be cleared out automatically after a few hours, otherwise they might need to be manually terminated.

Data Synchronization

Create Task Fails with Error "Same or Circular Task Exists"

Data Sync tasks are uni-directional and are sensitive to circular references. You cannot set up a bi-directional sync using two tasks and the same object storage buckets used by OCI and the REDs. Ensure that the task you are creating does not attempt to reverse the sync direction of a previously created task. If it does, modify one of the tasks needs to not reverse the direction of the other.

Tasks are specified, but sync operations do not start

Data Sync requires that you assign a connection for each REDs to an OCI cloud location where you want the data sync operations to occur. Check the [OCI status page](#) to see if OCI services are running. If network or object storage issues occur, resolve these issues before attempting to run or schedule a data sync. Next, see if the local network has connectivity by running `ping` OCI from the host machine to verify connectivity between Roving Edge Infrastructure and OCI. If pinging OCI does not work, verify that no firewall or network rules blocking connectivity exist.

If you create a Data Sync task job for synchronizing a bucket from RED-to-OCI or OCI-to-RED, and its estimated runtime is more than 12 hours, then exactly after 12 hours the Data Sync job fails because the authentication token expires after every 12 hours. If the Data Sync job fails after running more than 12 hours, do the following

1. Open the navigation menu and select **Data Sync**.

The Data Sync Tasks page appears. All data sync tasks are listed in tabular form.

2. Check the data sync task that failed.

3. Click **Start**.

Alternately, select the Actions menu (⋮) for the data sync task that you checked and click **Start**

4. Confirm the start when prompted.

Known Issues for

The following known issue is identified in Roving Edge Infrastructure.

- [An Oracle Linux 9 instance takes a while to boot](#) on page 276

An Oracle Linux 9 instance takes a while to boot

An Oracle Linux 9 instance might take longer than 4 minutes to boot.

Details

Workaround

1. In the instance, run the following command to check if the bootloader entry contains a `netroot` setting that's set to an `iscsi` target:

```
grep "netroot=iscsi" /boot/loader/entries/*$(uname -r).conf
```

2. If the command returns any result, remove the `netroot` option from the bootloader entries using this command:

```
sed -i 's/netroot=iscsi:[^ ]*\+ / /' /boot/loader/entries/*.conf
```